

Carry On Cottaging

*Houjun Jin 2019-2020 Project Research Diary
Platform 6 - Nonterior*



Neon sign, Soho

TITLE: SOHO STORIES

This year the Nonterior Platform is a series of live projects. Attempting an ambitious engagement with real-world contexts, you will each create projects that identify a site, a real-life client and a unique opportunity to design, produce and build a spatial experience. Your projects might inform communities; overcome social divides; develop reputations; and increase visitor numbers or attract new audiences. By promoting methods which are participatory, multi-layered and meaningful your projects could potentially challenge accepted economic, social, cultural, environmental, sustainable and democratic norms. We will be studying and experimenting with various processes: various ways of acting on and using the materials from the site. As a studio, our commitment will be towards testing, making, producing, and (eventually) building a real project.

CONTEXT: SOHO

The platform will study the effects of change on one of London's oldest and most colourful neighbourhoods, which is going through profound architectural and cultural transformation: Soho. The area is one of the most famous, well-known, well-loved – even notorious – neighbourhoods in London's West End, an entertainment district known for its permissive attitudes. Originally developed as a fashionable parish for the aristocracy, it has passed through many lives: theatres, churches, high end restaurants, strip clubs and artistic organisations jostle shoulders around its narrow and historic streets. This area is currently

Title: *Soho Stories*
Site: *In Soho area*
Time: *10.2019- 06.2020*

Aims and objectives:

- 1) *Each project will feature a nuanced and resolved design proposal.*
- 2) *Drawing from site research, each project will be site-specific to the context of Soho.*
- 3) *Each proposal will respond to detailed engagement with and input from clients, key stakeholders and professional practices.*
- 4) *While remaining fully engaged with stakeholder realities, projects will be full of character, personality and specificity.*
- 5) *We will gain a real and grounded understanding of construction processes and cost implications, material performance and sustainability issues.*
- 6) *We will devise ways to communicate our findings and designs to a wide range of audiences and using various media.*
- 7) *As a Platform, we will have learned and contributed to a series of live built projects in Central London, developing unique/individual practices informed by the realities of construction.*

Outcomes of autumn term:

Research Book, Narrative Artefact

28.10.2019:

Researched on the Internet

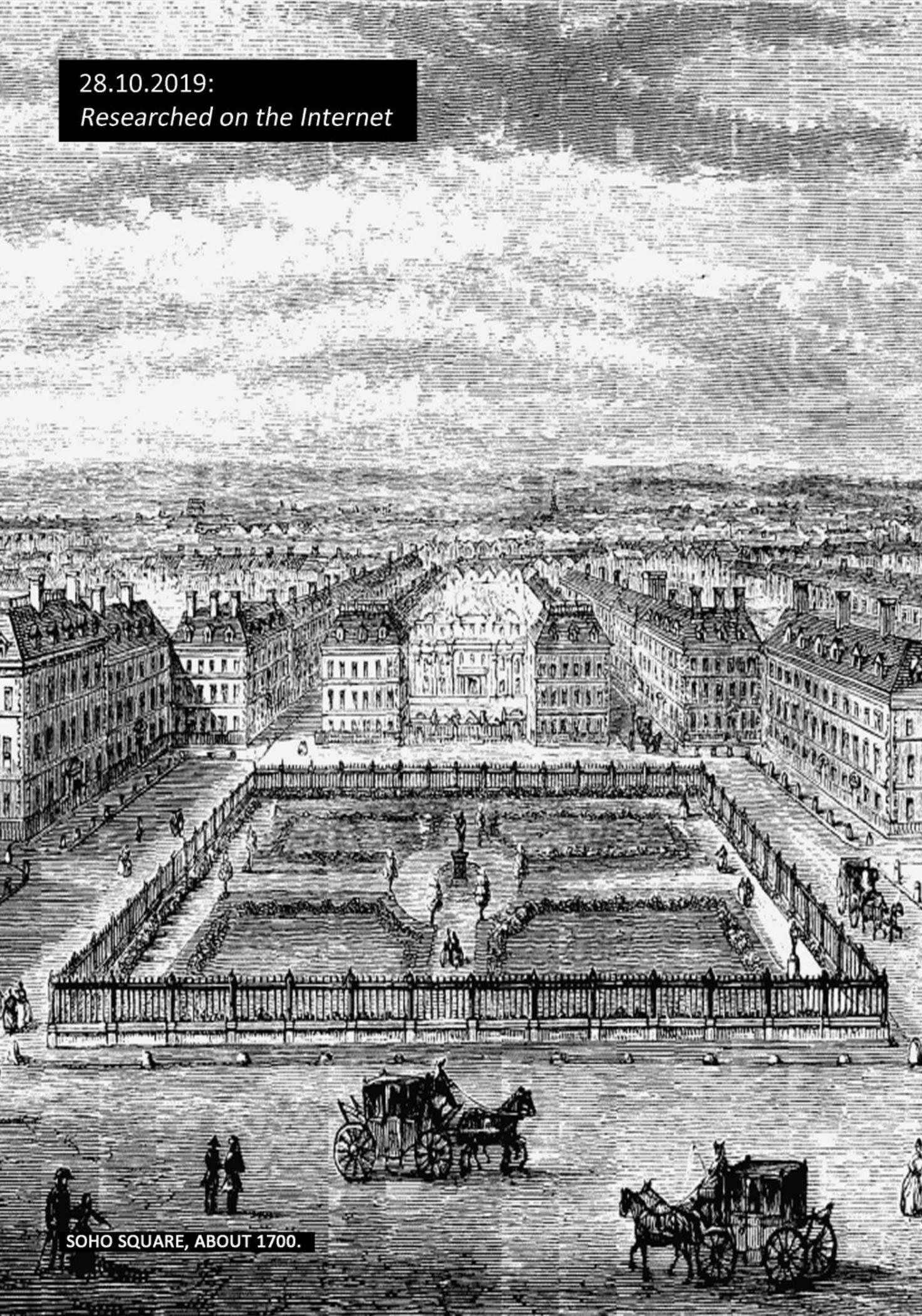

SOHO SQUARE, ABOUT 1700.

Soho history

The name "Soho" first appears in the 17th century. The name may possibly derive from a former hunting cry. Soho is an area of the City of Westminster, part of the West End of London. Originally a fashionable district for the aristocracy, it has been one of the main entertainment districts in the capital since the 19th century.

The area was developed from farmland by Henry VIII in 1536, when it became a royal park. It became a parish in its own right in the late 17th century, when buildings started to be developed for the upper class, including the laying out of Soho Square in the 1680s. St Anne's Church was established during the late 17th century, and remains a significant local landmark; other churches are the Church of our Lady of the Assumption and Saint Gregory and St Patrick's Church in Soho Square. The aristocracy had mostly moved away by the mid-19th century, when Soho was particularly badly hit by an outbreak of cholera in 1854. For much of the 20th century Soho had a reputation as a base for the sex industry in addition to its night life and its location for the headquarters of leading film companies. Since the 1980s, the area has undergone considerable gentrification. It is now predominantly a fashionable district of upmarket restaurants and media offices, with only a small remnant of sex industry venues. London's gay community is centred on Old Compton Street in Soho.

28.10.2019:

Researched on the Internet



Soho today

Soho is about 1 square mile in area now, bounded by Shaftesbury Avenue to the south, Oxford Street to the north, Regent Street to the west, and Charing Cross Road to the east. However, apart from Oxford Street, all of these roads are 19th-century metropolitan improvements, and Soho has never been an administrative unit, with formally defined boundaries. The area to the west is known as Mayfair, to the north Fitzrovia, to the east St Giles and Covent Garden, and to the south St James's. According to the Soho Society, Chinatown, the area between Leicester Square to the south and Shaftesbury Avenue to the north, is part of the area. Soho is part of the West End electoral ward which elects three councillors to Westminster City Council.

Since the decline of the sex industry in Soho in the 1980s, the area has returned to being more residential. The Soho Housing Association was established in 1976 to provide reasonable rented accommodation. By the 21st century, it had acquired around 400 flats. St Anne's Church in Dean Street was refurbished after decades of neglect, and a Museum of Soho was established.

29.10.2019:

Walked in Soho During Daytime



There are lots of blue Plaques on the buildings in Soho, they are telling the history behind the buildings.

Daytime Soho

This afternoon we walked around in the Soho area, and our tutors told us a lot of historical stories about Soho, which helped us learn more about this area.

I have passed by Soho lots of times, but today's visit made me find a lot of interesting things that I did not noticed before. From various types of churches to celebrity homes, from A Tale of Two Cities to the birth of vampire stories, from said dal to Chinese restaurants in Chinatown. I marvelled at the inclusiveness and diversity of the Soho area.

When we passed the Soho Square, daylight on the ground cast mottled shadows, people were lying on the lawn or sitting on benches enjoying their foods.

Reflection:

It seemed to have a calming effect on me. Today's walk increasing my sense of curiosity about Soho... I started to like this lovely area.

30.10.2019- 31.10.2019:
Stayed the whole evening in Soho



Even an abandoned helmet can cause a bad imagination in that evening, like: What happened to the owner?

Night-time Soho

Two of the women students in our group wanted to stay in Soho all night because of the needs of their projects, I decided to go stay with them. It was a rainy night, we walked in the alleys in Soho and tried to find out the difference between daytime and night-time life in this area.

The night was like a huge sieve, that excluded those ordinary people who were so busy during the daytime. This appeared to leave more distinctive people in Soho. At one o'clock in the morning, I saw a prostitute looking for customers on the street, then a "crazy" woman shouted at us. After that, we met a man with a foreign accent 3 times:

- 'Hey man! Do you want to buy some cocaine or marijuana?'
- 'No, Thanks bro.' I pretended to be calm.
- 'You can try it first.'
- 'No, Thanks!'

Reflection:

I love Soho, but night time Soho seems a bit dangerous. I feel in a short time I won't go there alone in the middle of the night.

2.11.2019:

Had conversations with people in Soho



No one knows soho more than a homeless person, so I had lunch with her.

Had Conversations with People in Soho

In order to get some interesting stories about Soho, I decided to talk to as many people as I could.

I had imagined that no one knows Soho more than a homeless person, so I decided to have lunch with a homeless woman I approached on the side of the road --- I bought a lunch for her and sat on the ground next to her-- in this way, she will feel more relaxed and I will have more chance to talk with the her.

Unfortunately, when I started chatting, I found out she could not speak English very well. I am also a foreigner, so this made our communication a bit difficult. She told me because she has no legal status, she cannot find a job and was in Soho every day because she can get a little more money here than other areas in London. During the meal, I sat on the ground, used my hands to finish my meal (I dropped my chopsticks on the ground because I am little bit nervous). My field of vision became very low, which gave me a different perspective, especially when people looked down at us.

Reflection

I felt different. It's weird, it is the same Soho, but it became different when you change your perspective to see it. Before I left, I asked her: 'Do you have any plans for the future?' She shook her head and told me no and then asked me for change.

I felt sad, and then I thought, maybe I can design something for her to make her life more comfortable. But then I dismissed the idea: She is about the age of me, should I help her live on the street for the rest of her life? Obviously, a homeless shelter is a better choice for her.

2.11.2019:
A shocking discovery



Broadwick St Toilet 26 Broadwick St Soho, London, W1F 8HX

A strange toilet in Soho

After lunch, I continue walking around in Soho, then I found a strange phenomenon in a public toilet.

I wanted to use the toilet, but the sign seemed intentionally covered by stickers, which I found confusing, I then noticed some men in line on the steps inside and leading down to the underground toilet, so I joined them. The man in front of me told me to go first.

'Thank you!' I said. When I was using the toilet, I realized that the man standing next to me was smiling at me, and I smiled back awkwardly after that he turned around and showed me his penis. I was very frightened and ran out immediately. The people in line still stood in place.

Reflections:

What are they waiting for!

The weirdest public toilet I have ever used!

on 2.11.2019:
A shocking discovery

ngly obvious here but DO NOT use the men's public toilets in Soho. Shit gets really...

142

Posted by u/NineFeetUnderground 3 years ago

I'm probably stating the blindingly obvious here but DO NOT use the men's public toilets in Soho. Shit gets really, really weird in there.

Right,

Sunday afternoon, heading to Berwick street & need a piss.

Find out Broadwick street has one of the last remaining public loos in there which isn't 30p. Great. Except it was full of people who weren't there to pee.

Go down the stairs, & there's a queue. Fine. I wait on the stairs. There's no movement but lots of unbearably awkward eye contact. People literally turning around and staring straight at me. Nobody looking at the urinals. Look at floor. After a minute or so, crane my neck & there's 2 free urinals making the queue suddenly bizarre. The room is miniscule.

Someone finishes at the urinal, walks away, doesn't wash his hands but doesn't leave either. Just loiters. Great.

[Start pissing](#) & the guy next to me is not even pissing, he's charming his snake and MAKES MORE EYE CONTACT.

Look the other way, guy at left isn't pissing either, but is staring straight into my soul as well.

Meanwhile The queue moves into the toilet as a group. It's a tiny room. I'm blocked in.

Turn around to walk out & I'm blocked on the stairs out by a Pilipino lad, more staring, more awkwardness. He deliberately gets in the way.

Run outside.

0/10 would rather piss my pants.

Don't make the same mistake.

79 Comments Share Save Hide Report 93% Upvoted

ADVERTISEMENT



Experiment, learn and build with our top services, free for 12 months

[Try Azure Free >](#)

This thread is archived
New comments cannot be posted and votes cannot be cast

SORT BY BEST

[deleted] 121 points · 3 years ago

This totally sounds like my kind of place, thanks for the tip OP

This is not a Accidental phenomenon

After that happened, I searched on the Internet with 'Soho public toilets' as the keywords, and I found the article on the left.

I realized that what I saw is not an accident phenomenon. I think I found an interesting story about Soho and decided to do more research.

5.11.2019:
What are they waiting for?



'The Stains' on the partition in the toilet

People have sex in that toilet.

I went to that toilet again today: to do a further investigation. After I researched on the Internet that day, I guessed people might have this toilet.

So, I talked with the waiter in the restaurant next to the toilet. He reminded me: 'Don't use that toilet, some people have sex in it.' I stood outside the toilet tried to record the length of time people spent in it.

After that, I realized that many of the men who entered the toilet stayed longer than 20 minutes. This afternoon, I got into that toilet, I saw two men were having oral sex and a group of people were watching them, when they saw me, the two man stopped, all of them started looked at me.

I run out again. "Get a room." 'Yes, they have sex inside it.' I thought.

6.11.2019:
What is 'cottaging'?



Peopel call it 'cottaging'

In following research, I found that people call this phenomenon, of sex in public toilets, 'cottaging'.

The Wikipedia gave this as an explanation of the term about 'cottaging' and 'cottage':

"Cottaging" is gay slang, referring to anonymous sex in a public lavatory (a "cottage"), or cruising for sexual partners with the intention of having sex. The term has its roots English toilet blocks resembling small cottages in their appearance. '

Cottage' usually means a small, countryside home, and having been in use during the Victorian era to refer to a public toilet and by the 1960s its use in this sense had become an exclusively homosexual slang term."

6.11.2019:

A news about Broadwick St cottage

News · West London News · Google

Even police 'won't go into Soho toilets' used by prostitutes and drug dealers

It's feared families and the elderly won't use the loos because of what goes on in them

By **Owen Sheppard** Local Democracy Reporter
11:47, 16 AUG 2019
UPDATED 14:02, 17 DEC 2019

SHARE      COMMENTS

Enter your postcode for local news and info Enter your  



MOST READ

-  The new strict rule that will affect London bus users from this year onwards
-  The sinister story behind Green Park London Underground station and how it got its name
-  The long forgotten London Underground station in Hounslow that was open for just

At Berwick Street Market, traders say the public toilets there still garner a "reputation" for those seeking to share in some public indecency. (Image: Pexels)

Sign up to FREE daily email alerts from [Getwestlondon - MyWestLondon News](#)

Enter your email **Subsc**

We will use your email address only for sending you newsletters. Please see our [Privacy Notice](#) for details of your data protection rights

There are those who say that Soho has cleaned up its act in recent years - that it has traded its raunchy reputation for something more touristy and sterile.

But in the back streets it seems its reputation as London's sex district is still alive and well.

Residents who live in the area - once notorious as a home of prostitutes and sex clubs - say Soho's WCs are still firmly on the map as gay cruising hot-spots and that it

People around it hate it.

I found a news report about Broadwick Street cottage on a website called 'My London'. In the news, I read about the attitudes of people around the cottage. Most of the residents and vendors around it have similar attitudes to the waiter I met in the restaurant yesterday: they do not want to use this toilet.

'Even police 'won't go into Soho toilets' used by prostitutes and drug dealers' the news said.

"They do very bad things in those loos, so I don't want to go in there when they are open. I stopped a Mum and Dad, from sending their two boys down there. They were probably eight and 10 years old. I said, 'you can't send your little boys in there.'" the man in the article said.

After reading this article, I was thinking, is it possible to design a new public toilet for the residents and vendors around the 'cottage' to make it easier for them to use?

I mean, a toilet without sex.

I should know more about that cottage.

In today's tutorial I told my tutors about what I found, saw and read in the past whole week, and told them about the attitudes of the residents and the vendors around cottage in the article, and discussed about the 'no sex toilet' idea.

Then they asked me a question: 'Why are they cottaging?' I could not answer this question.

They suggested me do not rush to decide what to design and do more research, be curious and I can start it with find out what people do inside it and draw the plan and the section of Broadwick Street cottage.

Yes, dialectical thinking is important. If I only think about the problem from one aspect, I cannot make a good design.

11.11.2019: Tutorial Day

Learnt the different funding models for project in Ernö Goldfinger House



'Design' the funding model for project

Today we visited the Ernö Goldfinger House in Hampstead, and our tutors organized a workshop for us about how early stage practitioners today might go about 'designing' the funding model for a contemporary design project today.

For me, it is very helpful. During the workshop, our tutors introduced lots of different funding models that can help us raise money for our project. Because in our platform our work will be very close to a real project, it means that we need to design for a real customer, looking for a real client to get fund. It is not only about design, I think the whole process will be difficult, but it will be very interesting, so I am excited. That one of the reasons I chose Nonterior.

12.11.2019:

Draw the cottage plan

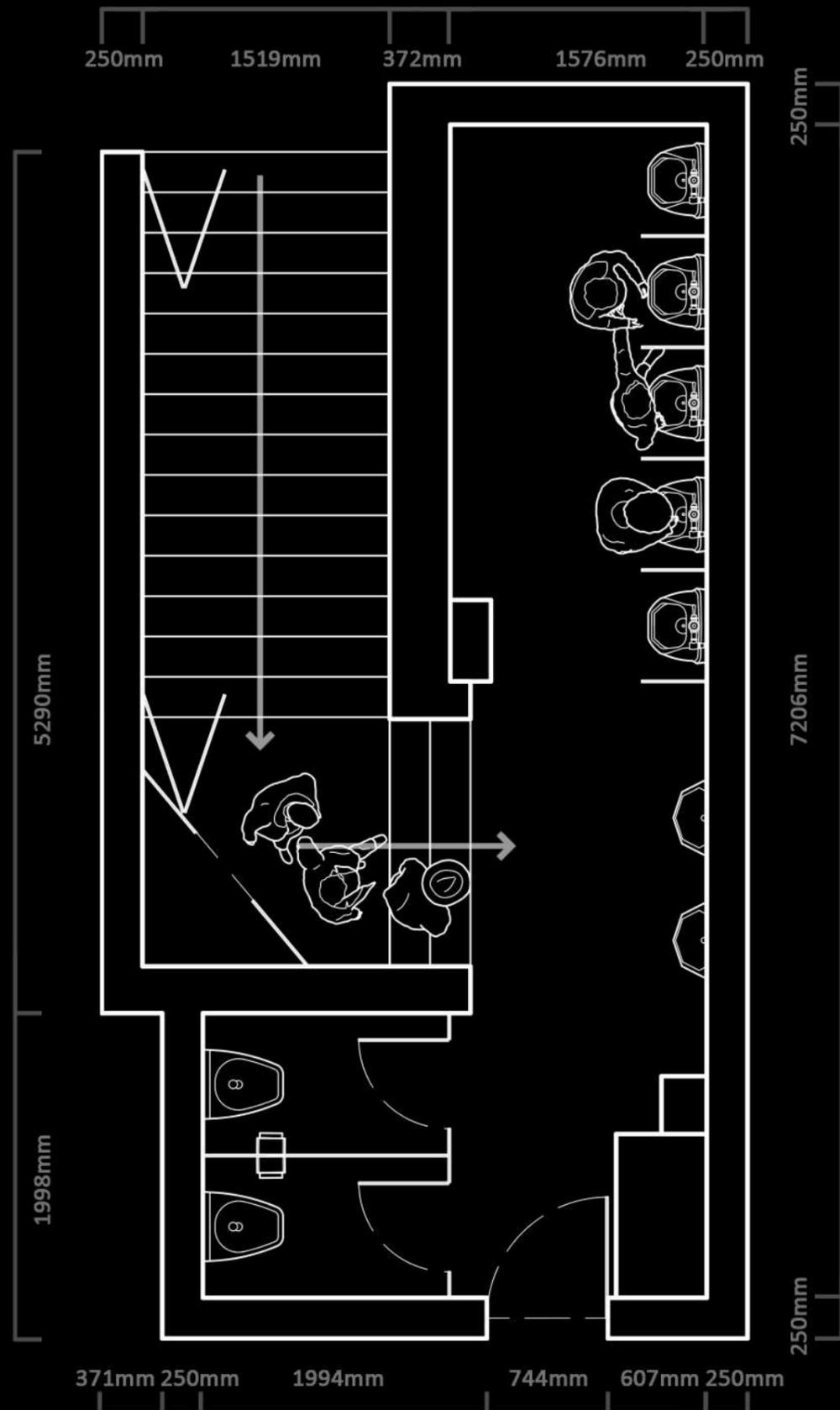

1:50 Plan of Broadwick St cottage

Take photos and draw the plan

The first thing to do this week is go to the cottage again, take photos, measure the size of the room and draw the plan.

I can take pictures and measure the size only when the toilet is empty. The cottage opens at 10am, so I waited outside of it at 9.30 this morning, then I met the cleaner of this toilet, he opened the door for me:

---'Are you all right?'

---'Yes, I'm doing some research.'

---'Are you?' with a meaningful smile on his face.

13.11.2019:

Sketchup model and explore the cottage

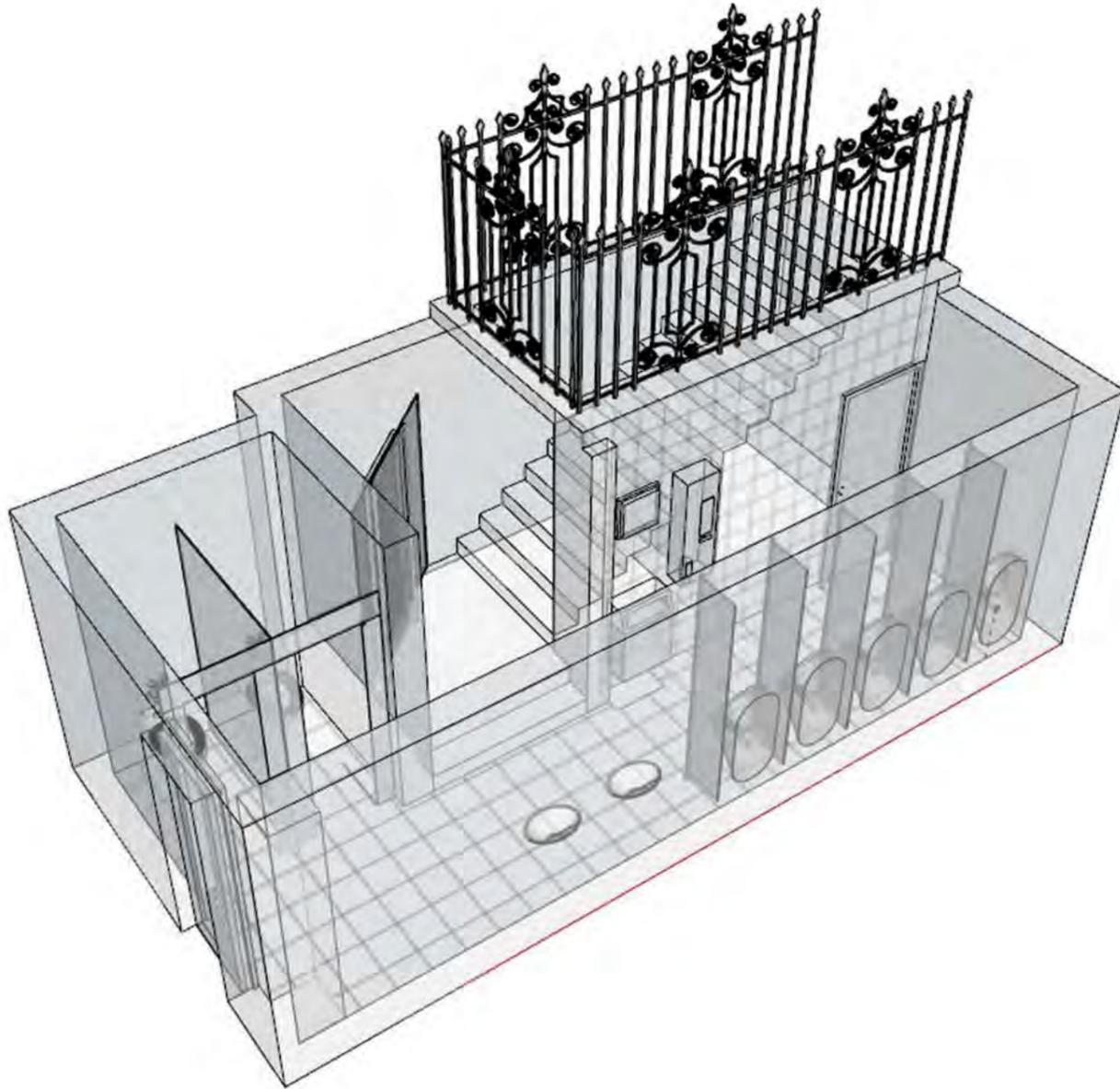

Built 3D model of the toilet

After I had the toilet floor plan, it was easy to build a 3D model of the cottage. The next task is to explore the cottage again to see how 'cottagers' use this public toilet.

So, I went to cottage in the afternoon, and there was still a queue in front of the entrance. Stood in front of the cottage entrance, I felt less nervous than before. I joined the line again, but this time, just like everyone else, I did not behave like I went there to use the toilet. After rejecting an 'invitation' of the two men, I found out the rules of using cottage. Stood in front of the cottage entrance, I felt less nervous than before.

Screenshot of cottage sketchup model

13.11.2019:
The Broadwick St cottage has its rules

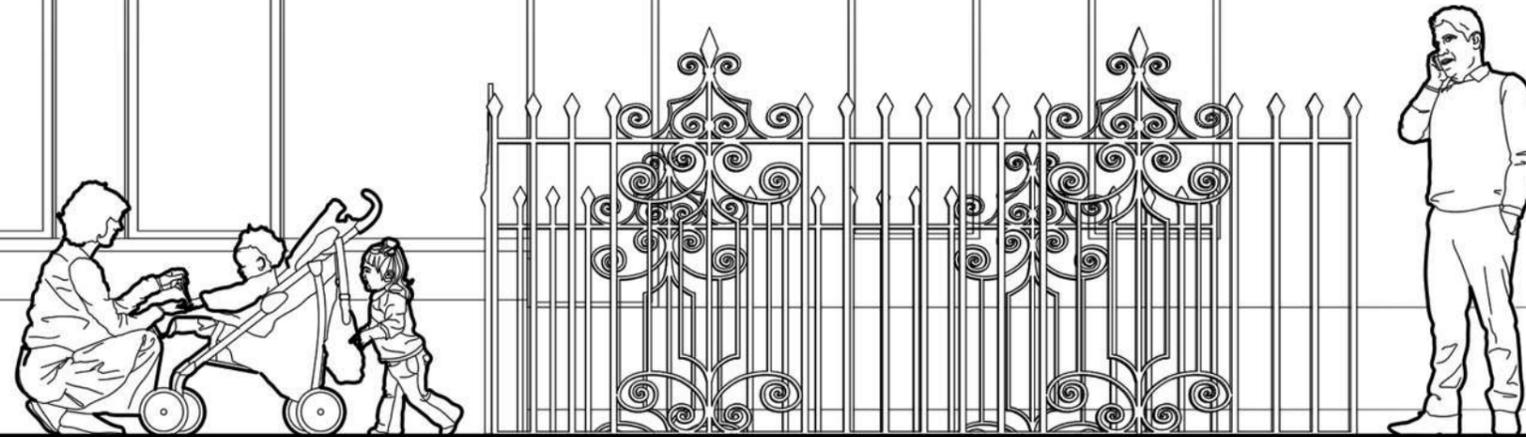

- ① **Rule No.1: Waiting Area.** 'Cottagers' who are looking for sex usually wait in this area, they use eye contact when they meet the right target . "
- ② **Rule No.2: Oral sex.** After both of them agree withthat they will have oral sex right in the toilet.
- ③ **Rule No.3: Two men having sex in the cubicle.** Before that happened, men communicate through the partitions. There's the cough or the foot moving slowly closer [under the partition], or tapping to see if you tap. All of which is also made easier, if there is a hole made in the wall between the stalls – called a glory hole. Through this, messages scribbled on toilet paper can be passed, or it can be looked through before action commences.'

- ④ **Rule No.4: Person pretend urinating.** Because 'cottaging' is illegal, people who are looking for sex usually stand in front of the urinal and pretend to urinate
- ⑤ **Rule No.5: Masturbation.** When a person stands in front of the urinal to masturbate, people will come around and watch
- ⑥ **Phenomenon 1: Unpopular condom machine.** 3 condoms cost 1 pound, but no one want to use them.

14.11.2019:
Tutorial Day

'Why they cottaging?'

At the moment, we already know how 'cottagers' use this space, so the next step is to find out why people "cottaging"?

19.11.2019: Interview Talked with the men inside the toilet

First Try

Time: 16:30 19.11.2019

Interviewee: A man around 65 years old



It was already getting dark at 4 o'clock that afternoon. I stood outside the Broadwick Street public toilet, hoping to find a suitable interviewee. Then an older man came out from the toilet, we had a brief eye contact. I smiled and said: 'Hi'. **He suddenly panicked and then immediately turned and walked away.**

Second Try:

Time: 16:45 19.11.2019

Interviewee: A man 26 years old



After my first try, I decided to get in to the toilet to find the interviewees. I entered the toilet and acted like other cottagers. The toilet was full of people, obviously they were not there to use the toilet. A short young man looked at me and gestured to me to go to the cubicle. I signaled him to go out with me. I successfully finished my first conversation: (A part of our conversation, organized according to memory)

-
- 'May I ask why you are here?'
 - 'Ha ha ha, you know the reason.'
 - 'Sorry it's my first day here, I am so curious, what do they do here?'
 - 'They usually give each other a blow job or wanking together.'
 - 'Do you come here very frequently?'
 - 'No! not very often.'
 - 'Do they know each other?'
 - 'No.'
 - 'Do you think these people are healthy? I mean, do you worry about hiv or other disease? Do they wear condoms?'
 - (This question obviously made him feel uncomfortable.)
 - 'No, I don't think they are clean, some of them don't care about it.'
 - 'Sorry, I have one more question, why do some of them inside there, pretended they were peeing?'
 - 'It's illegal to have sex here.'
 - 'The police arrested people?'
 - 'Yeah'

My continuous questioning obviously made him want to leave immediately, I decided to say something good.

- 'You seems a nice person, why don't you find a boyfriend instead having sex here?'
- 'No, I can't. I living with my cousin, he don't know I'm gay, also I can't let him know.'
- 'He won't accept it?'
- 'No!'
- 'So do you have any plan for the future?'
- 'I don't know.'

Third Time

Time: 17:03 19.11.2019

Interviewee: A man around 50 years old

- 'Hi May I ask why you are here?'
- 'You want a blow job?'
- 'No, thanks.'
- 'Ok.'
- 'May I ask why you are here? Don't you have a husband?'
- 'No, I married with a womam'
- 'Cool, so you are bi?'
- 'No, I'm gay.'
- 'Cool, so your wife know you are gay?'
- 'No.'
- 'Ok, so how often do you have sex with your wife?'
- 'No. I don't have sex with her.'
- Ok.

From this I am felt with the thought that the reason why people are 'cottaging' is because their sexual identity is a secret.

19.11.2019:
Is cottaging illegal?

"You see guys hang around waiting for a nod to go down there. They're cruising.

"Sometimes when there's police patrolling I ask them to go down there as a deterrent, but they don't want to. And they're the police.

▲ A part of an article from the Internet

<https://www.mylondon.news/news/west-london-news/soho-public-toilets-nightclubs-children-16765957>

Yes, it is illegal, but sometime it is hard to say if it is

— 'Why some of them inside there pertended they were peeing?'

— 'It's illegal to have sex here.'

— 'The police arrested people?'

— 'Yeah'

---From yesterday's conversation

After I researched, I revealed:

Under 73 of the Sexual Offences Act 2003 (SOA 2003) 'engaging in sexual activity in a public lavatory' is outlawed. This applies to heterosexual and homosexual sex acts. If an offending couple are caught committing/having committed a sexual act in a toilet to which the public or a section of the public has or is permitted to have access (whether on payment or otherwise), they may be prosecuted. You risk being arrested for cottaging regardless of whether you are being discreet or not. For example, having sex in a cubicle behind closed doors is still against the law.

However, in recent years police have adopted a more softly-softly approach and will probably only get involved if members of the public complain.

20.11.2019:

Read more articles

Understanding how it worked enabled Michael to return. "I became transfixed by this place," he says. But he wasn't simply looking for quick, anonymous sex. "I wanted to meet someone that I could express all this physical passion with and direct it to someone I love."

"A family friend molested me," he says. Steve was 7. Aged 11 or 12, he told one of his brothers. "He said, 'You can't mention that to anyone because if that's true that makes you a homosexual and our father has said that if he had a gay son he'd throw them out the house.'"

"It feels like the dominant culture says, 'Oh well, if you've got this [apps], then you shouldn't want this [cottages].' Well, who says?"

"It was a dirty, stinky toilet," he says, his Stoke accent resonating through a rich voice that vibrates widely. "People were writing things like 'get sucked off here' and 'I'm here between 5pm and 7pm every day' with some pornographic drawings. I remember it being incredibly terrifying and incredibly exciting at the same time. I was like, Oh, there's another world. That's the first time I knew there were other gay people."

The toilet offered something else: hope of connection. "There became this fantasy," he says, "that I would find a boy that was like me."

"The establishment of affective and erotic intimacy in a space in which we are all strangers to another is a profound affirmative of human life. I don't accept any narrative of queer life that wants to deny the value of those relationships, those moments of relation."

At some point, cottage is a sanctuary

After a month of research, I met a variety of people in the cottage. By talking with them, reading articles, my attitude to the cottage start to change.

The people in the cottage are forced by various environmental pressures to hide their sexual orientation in daily life. Only in this dim and dirty public toilet they can take off their masks and become themselves. I started to think that the existence of cottage have it own reason.

For us, it is just a toilet, but for them, it is a sanctuary.

▲ Different views of people on the internet about their cottaging experience

27-25.11.2019:

Continue research: Research on homosexual psychology

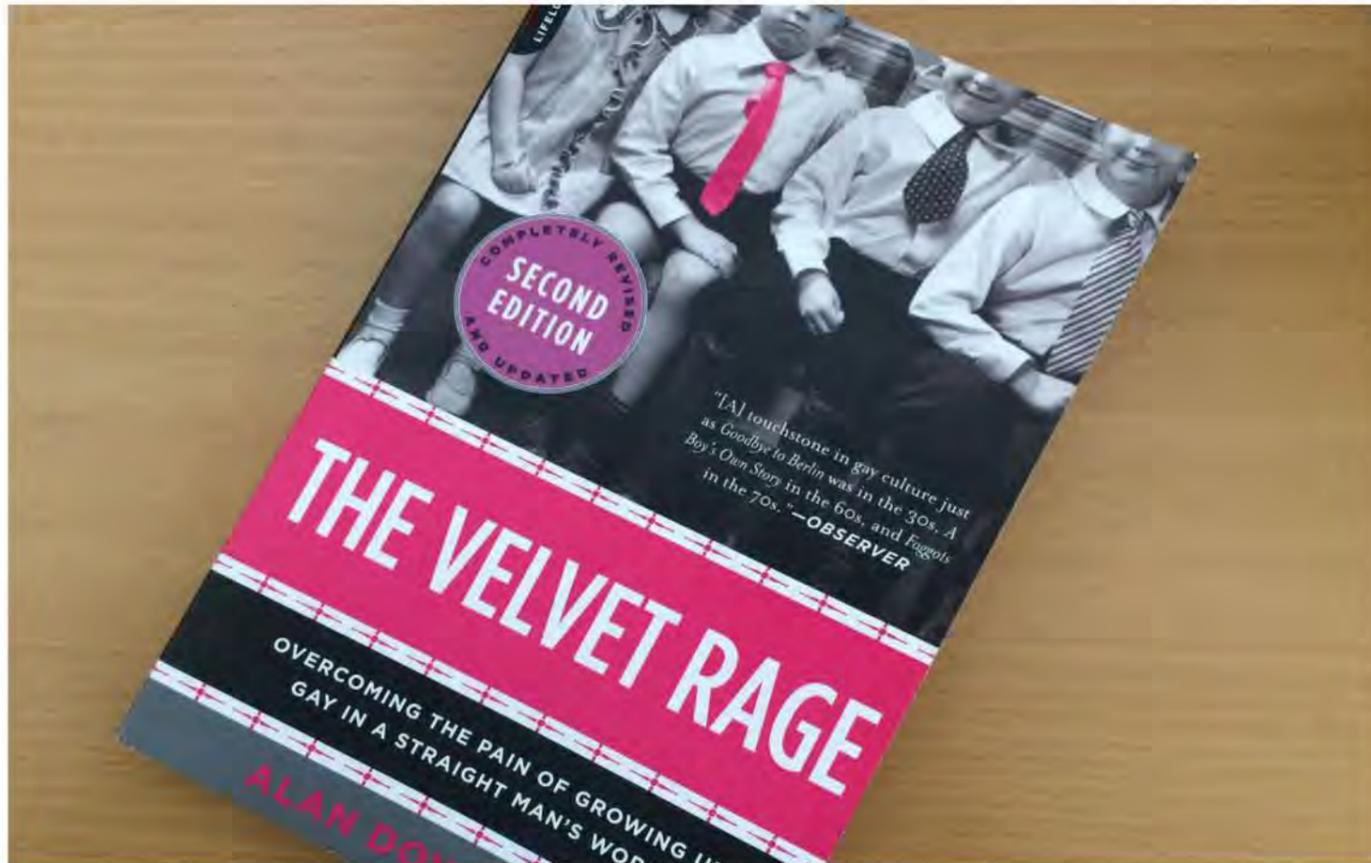

Action

A week ago, Claudio recommended a book on homosexual psychology called "The Velvet Rage", in order to be able to understand deeply about the LGBT subculture, and understand the psychology of 'cottagers' I start to read this book, I found it helped me a lot.

Reflections

I started to understand such a group of gay men, as they grew up, they gradually discovered that they were different. At the same time, they realized that such a different self could not be accepted by their surroundings, they were often educated: boys must be like boys. So, they learned to start hiding their secrets. And subconsciously always think that they have the characteristics of 'unlovable'. This growth experience makes it difficult for many gay men to disclose their sexual orientation to those around them even when they grow up.

Action

After a month of research, I met a variety of men in the cottage. By talking with them, reading articles and books my attitude to the cottage began to change. The people in the cottage are forced by various environmental pressures to hide their sexual orientation in daily life. Only in this dim and dirty public toilet they can "take off their masks" and become themselves. I started to think that the existence of a cottage has its own reason. For us, it is just a toilet, but for them, it is a sanctuary.

28.11.2019:

Precedent study 1---Sex Furniture 'Satyr'



“Dutch Design Week 2015: Design Academy Eindhoven graduate Bastiaan Buijs has designed a sex toy with a bright pink torso that can be mounted like a vaulting horse.

The toy requires the use of the "whole body", and rests on four splayed maple wood legs – in the style of a traditional vaulting horse found in a gym. Its name refers to the horse-like creatures from Greek mythology, which were notoriously mischievous.

Buijs' product is designed to be used like a flashlight: a male sex toy shaped to mimic the feeling of penetrative sex when the penis is inserted into its silicone form.”

Reflection

The inspiration I got from this project is that the designer merged sex toys and furniture, which reminded me: Is it possible to redesign common items in toilets keep their basic functions but also make them so they can be used as sex toys?

28.11.2019:

Precedent study 2---Sex toy 'Buck off'



'Trans activist and entrepreneur Buck Angel has created a sex toy designed specifically for gender-transitioning men. The Buck Off is a masturbation aid made for people who have transitioned or are currently transitioning from female to male.

Although it is largely based on regular masturbation sleeves, the Buck Off is shorter and wider, and features a ridged inside that creates suction. It also has the advantage of allowing transgender men to masturbate without touching their genitals directly, something Angel hopes will help individuals who don't feel comfortable with their own body."

The reason this precedent caught my attention is that it looks similar to a door handle (as shown on the left), so it made me think if replacing the door handle of the toilet cubicles with sex toys would allow people to use the toilet normally but at the same time, "cottagers" can also take them off and use as a sex toy?

29.11.2019:
An idea from a news



When I tried to continue my research on precedents, a piece of news caught my attention. In 2004, the artist Paul McCarthy placed an inflatable work with a height of 24 meters named "Tree" on Place Vendôme in Paris. Although the name is "Tree", the appearance of the whole work is more like a sex toy. So, this work was deemed (unacceptable? and) destroyed within a day of installation.

Reflection

After reading this, I thought, since sex toys can cause discomfort for some people, if we replace the door handle of the toilet with a homosexual sex toy, perhaps people who cannot accept 'cottaging' will not touch the door handle or use the toilet, so it can provide an undisturbed sex space for those 'cottagers' in the toilet?

Maybe I could test this?

03.12.2019:
'Door handle' making



The first task today is to go to a sex shop to buy 'raw materials' suitable for door handle: Firstly, this sex toy must be used in gay sex. Secondly, it must be able to visually discomfort some people. So, in the end I bought a dildo.

Then I used spray paint to spray it orange, this is mainly to reduce its authenticity and hope to highlight it on the existing blue toilet door.

03.12.2019:

04.12.2019: Tutorial day

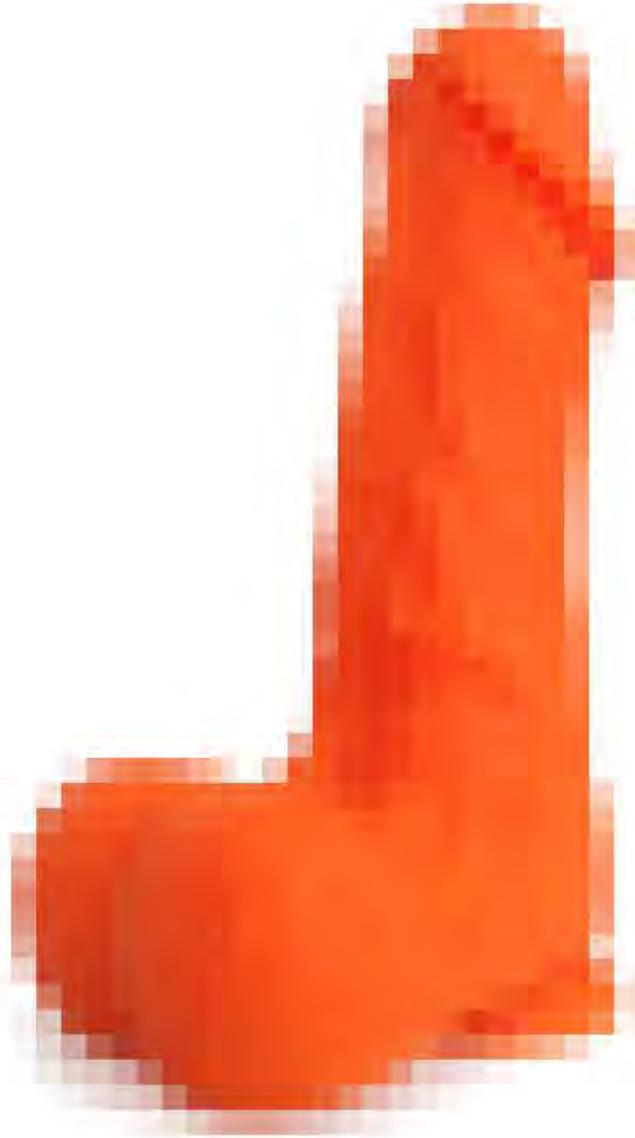

When I woke up this morning, I found that after spray painting the 'door handle' not only did not dry but also melt because the chemical reaction between the silicone and the paint.

Today is tutorial day, I hesitated for a really long time and decided to put it in a cardboard box and take it to college. During the tutorial, after I opened the box, everyone was shocked, at that moment I realized t this action made me look like an exhibitionist, then I sweated a lot, I do not know what I should do. I didn't even make it clear what the purpose of doing this is: even this is a particularly stupid idea. My tutors felt my embarrassment and gave me many suggestions to help me determine what to do next.

After the tutorial, I fled the college as quickly as possible: "After I did this, I never want to come back again..."

05.12.2019:

Reflection about this week

Reflections

After waking up this morning, I realized things:

1. The biggest problem with this idea is that it is too straightforward, the whole idea is simple, without lots of thought, it is not smart, so it is looks cheap.
2. Secondly, yes, I took a dildo to the college yesterday, so? I cannot give up just because of this. Sex is the topic of my project. It is special, so every time I present it, I must discuss it academically and confidently so other people can take my project seriously.

09.12.2019:
A moveable toilet partition

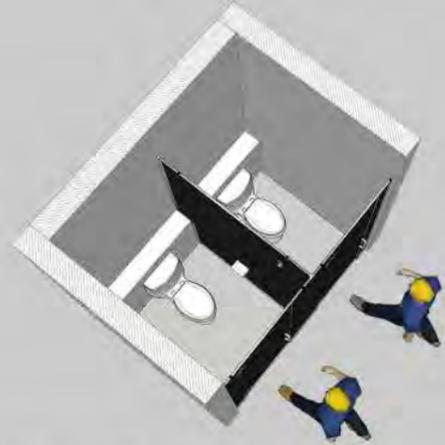

☒ Get into difference cubicles



☒ If the police come



☒ Open the special partition



☒ Put the partition back



☒ Double space for sex



☒ Leave like a boss

▲ Some sketches about a removable partition idea

'Cottagers-friendly' Design

The sketches on the left is one of my ideas about a movable partition. I tried to meet the cottagers' "safer" sex needs with the least change in the original toilet.

10.12.2019:
Tutorial Day



This 'cottage' might be closed in the future

During today's tutorial I talked about the moveable partition with my tutors, then Kevin shared an article about Broadwick St toilet might be closed in the future. It says that at least 1,782 facilities have closed across the UK in the last decade. According to the Evening Standard, Westminster Council is considering replacing existing facilities with portable toilets in the future. This is due to contract disputes and economic issues.

Reflections

So now this project should focus on: How to provide a reliable environment for cottaging if the cottage on Broadwick St is closed in the future.

The another public toilet was closed during this week's research

16.12.2019:

How much does it cost to rent a hotel room in soho?

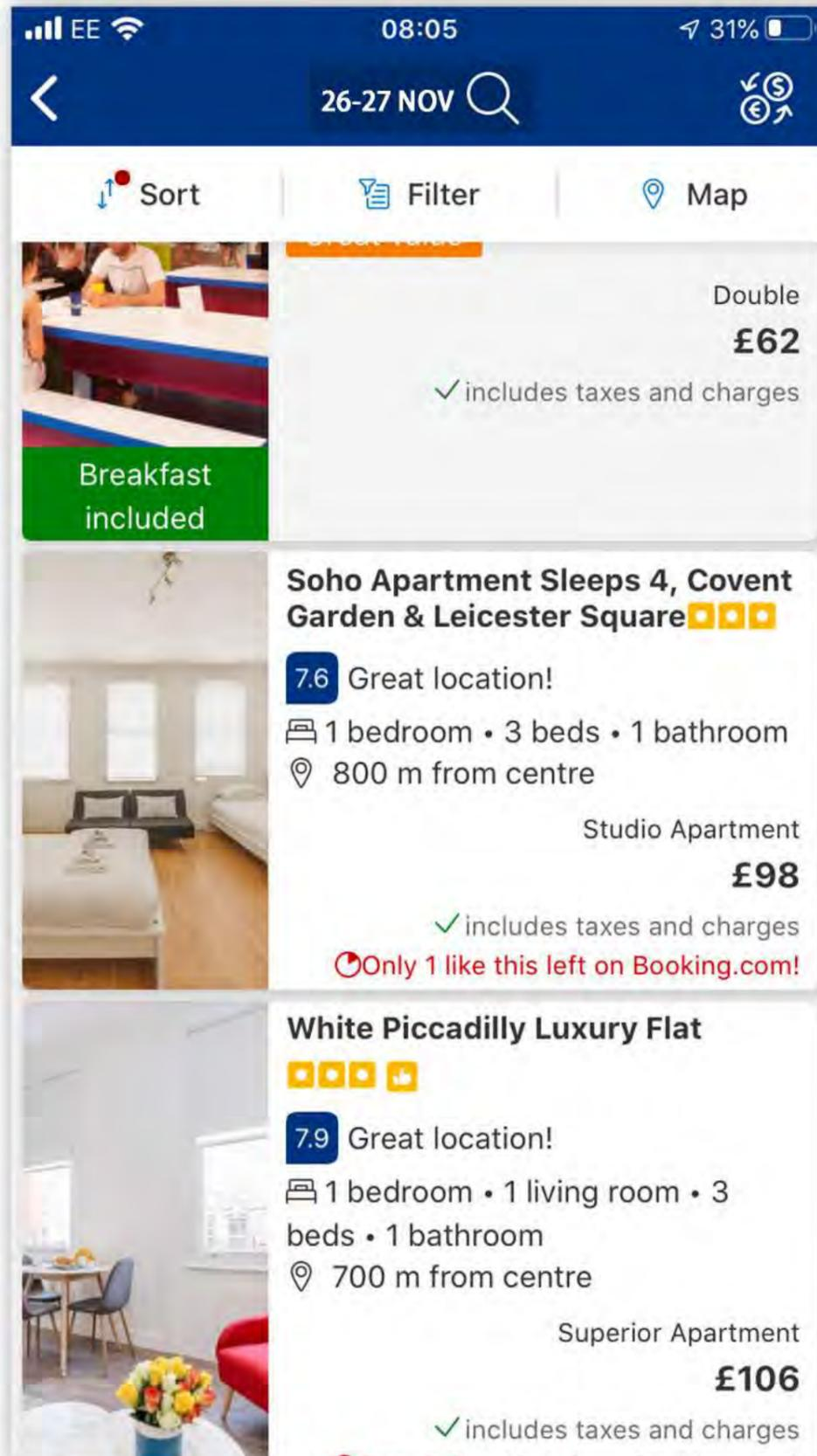

At least £62

Recording

If the cottage on Broadwick Street is closed in the future, can people use a hotel room nearby? Reflection

In order to verify the feasibility of this method, I researched rooms in Soho area on an app called 'Booking'. The result is shown on the left, the lowest room price in that day was £ 62. If people use it for only 1-2 hours, it is obvious too high for them. I do not think most people would consider that as an option.

Action

So, I now considered designing some "hour hotels" for them in Soho.

17.12.2019: *Field*
Research Find a site for



HOUR 'HOTEL'

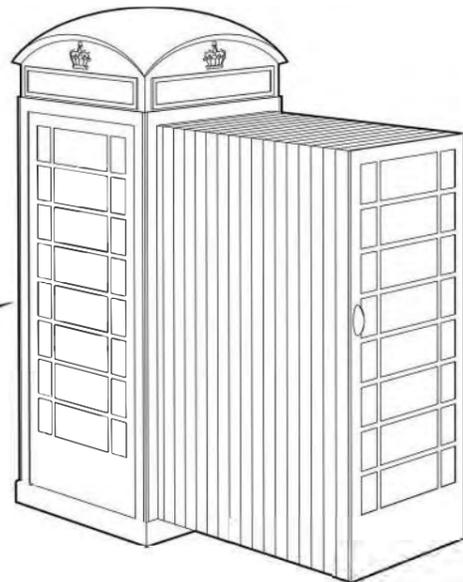

▲ Sketch of hour hotel

Adapting phone booth into a hotel

When I walked in Soho, I realized that just like the other areas in London, Soho has many abandoned telephone booths. So, I thought could I change one into a "temporary hotel" for two people by adding a stretching structure to the original telephone booth?

'The biggest problem: The hotel' can not hide cottagers' identity

During today's utorial my tutors pointed out that the hotel can not cover the identity of cottagers at all. On the contrary, the strange shape of it seems attract more attention.

13.01.2020:
Some idea about artefact

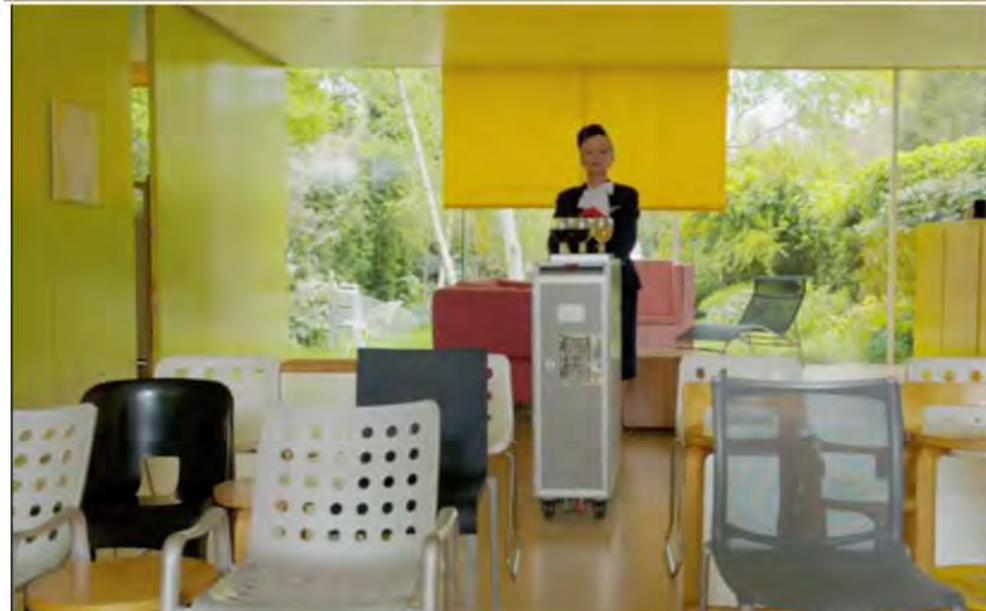

Making memories

I think it needs to be narrative, that is, able to describe the results of the previous survey and my personal attitude.

Since I learned that the toilet may be closed during a period of investigation, I decided to make it with scent and memory as keywords. The screen shots on the right are a precedent about how to retrieve memories:

In the video, a retired flight attendant puts on her uniform again, turns on a special machine, and stands on it. She starts pretending to distribute drinks to passengers. This machine can simulate the noise and vibration generated when the aircraft is sailing.

In this way, the designer helps the flight attendant to retrieve the lost memory. This precedent gave me some inspiration: maybe I can do something for "cottagers" to help them retrieve their memories of the toilet after Broadwick street toilet is closed.

13.01.2020:

Some idea about artefact



Smell and memories

I think one of the most impressive features of Broadwick Street toilet is its smell-the smell of urine in public toilets. So when I made this artefact, I chose to put urine in a perfume bottle to simulate the smell of the toilet.

03.02.2020:

Why we need to save the 'cottage'?



Oscar Wilde was arrested on charges of "gross indecency" under Section 11 of the Criminal Law Amendment Act of 1885 and sentenced to two years of prison

History: 'Cottage' is a record of LGBT history

'Architecture speaks a language of its own... and above all, a building, like an historical picture, must tell its own tale.'

---John Soane

Fifty years ago cruising and cottaging weren't the fetishes or fantasies that they arguably are now; they were a necessity — As gay relationships were criminalised, cottaging was the only way for most men to meet other men, albeit it a risky one.

From the early 1950s, there was a witchhunt afoot, with Conservative home secretary David Maxwell Fyfe vowing to "rid England of this plague" as he despatched undercover policemen to prowl in parks, cruising grounds and public toilets.

Their enticements led to the imprisonment of an estimated 1,000 gay men each year but that didn't put a stop to the covert goings-on. That's because, to most gay men, cruising and cottaging represented the only way for them to explore their sexuality.

So from a historical perspective, "cottage" is a historical product from a less tolerant age, it a record of a part of an important history of LGBT culture.

03.02.2020:

Why we need to save the 'cottage'?

Now: Pople still need cottages

"It feels like the dominant culture says, 'Oh well, if you've got this [apps], then you shouldn't want this [cottages].' Well, who says?"

---A 'cottager' said on the Internet

Why people still need a cottage in the age of Grindr? I asked a lot of cottagers this question during the research, So I got the following reasons:

1. To most cottagers the habit lives on because it is too far embedded in gay culture to snuff it out overnight.
2. Cottage offers a easiest and cheapest way for people to meet and have sex.
3. It is anonymous, for 'cottagers' it has two benefits:
First, it provides protection for those people who do not want to disclose their sexual identity, for some people it is still the only way to meet other gay people. Emotionally, cottage gave them a sense of belonging, and a place to respite.
Secondly, compared to Grindr there is less little communication so they can fill in all the unknown bits with their perfect fantasy of who they are, this is more exciting.

What we've seen is that no matter how hard people try to make cottaging not happen, no matter how many times people renovated toilets or kick the gays out, people still cottaging. 'What is rational is real; and what is real is rational.'

A person wearing a bright blue button-down shirt under a black jacket, black trousers, and brown leather shoes is walking on a city street. They are holding a black cane in their right hand. The background is a blurred city street with other pedestrians.

04.02.2020:

Why we need to save the 'cottage'?

Gentrification is changing old areas like Soho.

Future: Save the cottage --- the need of develop a diverse city

"Cruising is a really accurate thermometer of a city being democratic...a city that is not able to foster new ways and radical ways of having sex, is a city which is obsolete."

---Teyssou, The curator of Cruising Pavilion

For the future development of cities, we should not only focus on economic development. The diversity of cities is also important. We should build a city that allows everyone to live in the way they like and let them be able to feel safe and free.

Soho is a diverse area like this, but in recent years Soho is under threat from gentrification and corporatisation that threatens to rob it of what makes it so special. Researchers from the University of Kent and Middlesex University's study explains how the area is being sanitised with the number of licensed sex shops in the area declining from more than 50 to just 12. The research said Soho had an important role in "creating a space" for "sexual others" that in many other places ends up pushed out to the periphery.

Westminster City Council has a responsibility to ensure that Soho remains an open and vibrant space for all Londoners, not an elite few. The process of gentrification in this area has further marginalised already vulnerable groups and the sanitisation of the area. Soho's unique character as the historic heart of the LGBTQ community will be eroded or destroyed completely if we don't pay attention to the changes being made to the area and demand that Soho remains a diverse and open space.

04.02.2020:

How can we save the 'cottage'?

The image shows two screenshots from the Change.org website. The top screenshot displays a petition titled "Save VICTORIA TOWER GARDENS : no building in this precious London park!". It features a photograph of the park, a progress bar showing 12,812 signatures out of a goal of 15,000, and a sign-up form with fields for first name, last name, email, and location (Kensington, W8, United Kingdom). The bottom screenshot shows a "What kind of issue are you petitioning on?" selection screen with various categories like Animals, Human rights, Health, Environment, Politics, Local, Economic equality, Women's rights, LGBT rights, Criminal justice, Migration, Education, Disability, Racial justice, and Other.

Method One: Petition

How petitions work

You create a petition. Only British citizens and UK residents can create a petition.

You get 5 people to support your petition. We'll tell you how to do this when you've created your petition.

We check your petition, then publish it. We only reject petitions that don't meet the standards for petitions.

British citizens and UK residents can then sign your petition — and can only sign a petition once.

The Petitions Committee reviews all petitions we publish. They select petitions of interest to find out more about the issues raised. They have the power to press for action from government or Parliament.

At 10,000 signatures you get a response from the government.

At 100,000 signatures your petition will be considered for a debate in Parliament.

Example: A petition on the Internet to protect Victoria Tower Gardens

04.02.2020:

How can we save the 'cottage'?

BBC [Sign in](#) [News](#) [Sport](#) [Weather](#) [iPlayer](#) [TV](#) [Radio](#)

NEWS LONDON

[Home](#) [World](#) [UK](#) [England](#) [N. Ireland](#) [Scotland](#) [Wales](#) [Business](#) [P](#)
[Sci/Environment](#) [Technology](#) [Entertainment & Arts](#)

7 April 2013 Last updated at 08:19 [f](#) [t](#) [e](#) [l](#)

Historic Nunhead pub revived as community co-operative

By Joe Miller
BBC News, London



The 1930s' pub is an example of an interwar pub which has survived intact

Elvis Costello, Ian Dury and Joe Strummer have played on its stage, but last year the Ivy House in Nunhead, south-east London, was destined to be turned into flats.

Now, thanks to the efforts of a group of local residents, it is on the way to being re-opened as London's first community pub, owned and run by shareholders.

The campaign to save the Ivy House began last April after the tenant landlord was given five days' notice to quit.

But a group of locals, who met in the pub while having a farewell drink, formed a plan to save their treasured boozier.

They set up a formidable team including a real-estate litigation lawyer, a conservation adviser and a town planner.

Grade II listed

First, they accelerated an application to get the pub designated as a Grade II listed building.

Related Stories

- [Squatters take over historic pub](#)
- [Community sells final pub shares](#)
- [Shares in community pub on sale](#)

Method Two: Assets of Community Value (ACV)

Assets of Community Value (ACV): The Localism Act 2011 allowed communities to ask their local council to list certain assets, for instance, shops, pubs or other local facilities, as being of value to the community. If an asset is listed, and comes up for sale, the community then has six months to put together a bid to buy it. Civic Voice has published further information on ACVs, and the Campaign for Real Ale (CAMRA) has published advice specifically relating to pubs. Your local council should provide further information and a nomination form.

People protect ivy's house with Assets of Community Value

04.02.2020:

How can we save the 'cottage'?

Historic England

Listing and Designation Application Form

Contact Type Identify Location Extent Threat Ownership Reasons Photograph Documents Comments Summary

Identify Your Application

* Mandatory Fields

Subject: *
Broadwick toilet
e.g. Grove Farm, Barn and Farmhouse
e.g. Ring ditch in Kings Field, Littletown
e.g. Wreck of the Wellington off Plymouth Sound
e.g. Kiveton Park and Garden, Kiveton
e.g. Marston Moor Battlefield, North Yorks

Specify the primary County or Unitary Authority for the subject of this application: *
London

Do you need help with this section?

Previous Step Save & Return to Application List Save & Next Step

© Historic England 2015

Method three: Listing

Almost anything can be listed – it does not have to be a building. Buildings and structures of special historic interest come in a wide variety of forms and types, ranging from telephone boxes and road signs, to castles. Historic England has created twenty broad categories of structures, and published selection guides for each one to aid with assessing buildings and structures. These include historical overviews and describe the special considerations for listing each category. Both Historic Environment Scotland and Cadw produce guidance for owners

05.02.2020:

How can we save the 'cottage'?

How to Save a Building

Are you worried about a building in your area? Perhaps it is an old stalwart, a bit battered around the edges, or a landmark building that means something to you and your neighbours? Perhaps it is not now getting the care it needs or is the subject of rumours that it is going to be redeveloped? Here are some of the ways which might help you save it.

Listing: Buildings which are of national "special architectural or historic interest" can be listed, although the tests are strict. If you do think there is an unappreciated gem in your neighbourhood you can find out more about listing or see our step-by-step guide to making a listing application.

Local Listing: Your local council may keep a "local list" of buildings which make a strong contribution to the character of the area. It is worth checking the council website to see if there is a local list, and what kind of buildings are on it. Historic England has published advice for local authorities on how to prepare a local list, which you may find helpful.

Assets of Community Value (ACV): The Localism Act 2011 allowed communities to ask their local council to list certain assets, for instance, shops, pubs or other local facilities, as being of value to the community. If an asset is listed, and comes up for sale, the community then has six months to put together a bid to buy it. Civic Voice has published further information on ACVs, and the Campaign for Real Ale (CAMRA) has published advice specifically relating to pubs. Your local council should provide further information and a nomination form.

Local Civic or Amenity Societies: Local societies interested in the historic environment or maintaining valued local facilities may be a good source of support. Civic Voice publishes information on how to find a civic society local to you.

Charitable or not-for-profit organisations: Public funding is available to those working to save heritage at risk, with support and guidance provided by the Heritage Trust Network (HTN). Through events, peer-to-peer networking, advice and a step-by-step toolkit, HTN aids regeneration for broad ranging end uses.

National Amenity Societies: These voluntary societies were set up to preserve the art and architecture of past centuries and promote appreciation of such buildings and the cultures that produced them. They may be able to advise you on particular types of building.

17.02.2019:

Some questions that I should focus on



Where do people have sex ? And why they choose this space for sex?

Before starting the final 'cottage' design I realized that I should first focus on some important questions: Where do people have sex ? And more importantly why they choose this space for sex? What makes the dirty public toilet became the most popular 'cottage' in Soho?

In order to find out what characteristics of a space suitable for sex should have, I decided to use three methods to find out the answers to this question: check online, workshops and read related articles.

What makes the dirty public toilet became the most popular 'cottage' in Soho?

17.02.2019:

Method 1: read related articles

dezeen  Next story

consideration as they are often out of sight to the public.

"A really interesting thing happens when you start to investigate the kind of design that does somehow happen anyway, either in purposely built spaces or the serendipitous design."

The design elements of cruising spaces

Spaces intended for cruising frequently adopt architectural features such as labyrinths, nooks, recesses to cater for hiding places and chance encounters.

"The darkroom is a rather recent architectural invention," said Perrault. "It uses several anti-modernist spatial strategies. It embraces the labyrinth, the maze and darkness as an architectural device which is precisely what has been eradicated for the last 300 years by all sorts of architecture whether public or private."

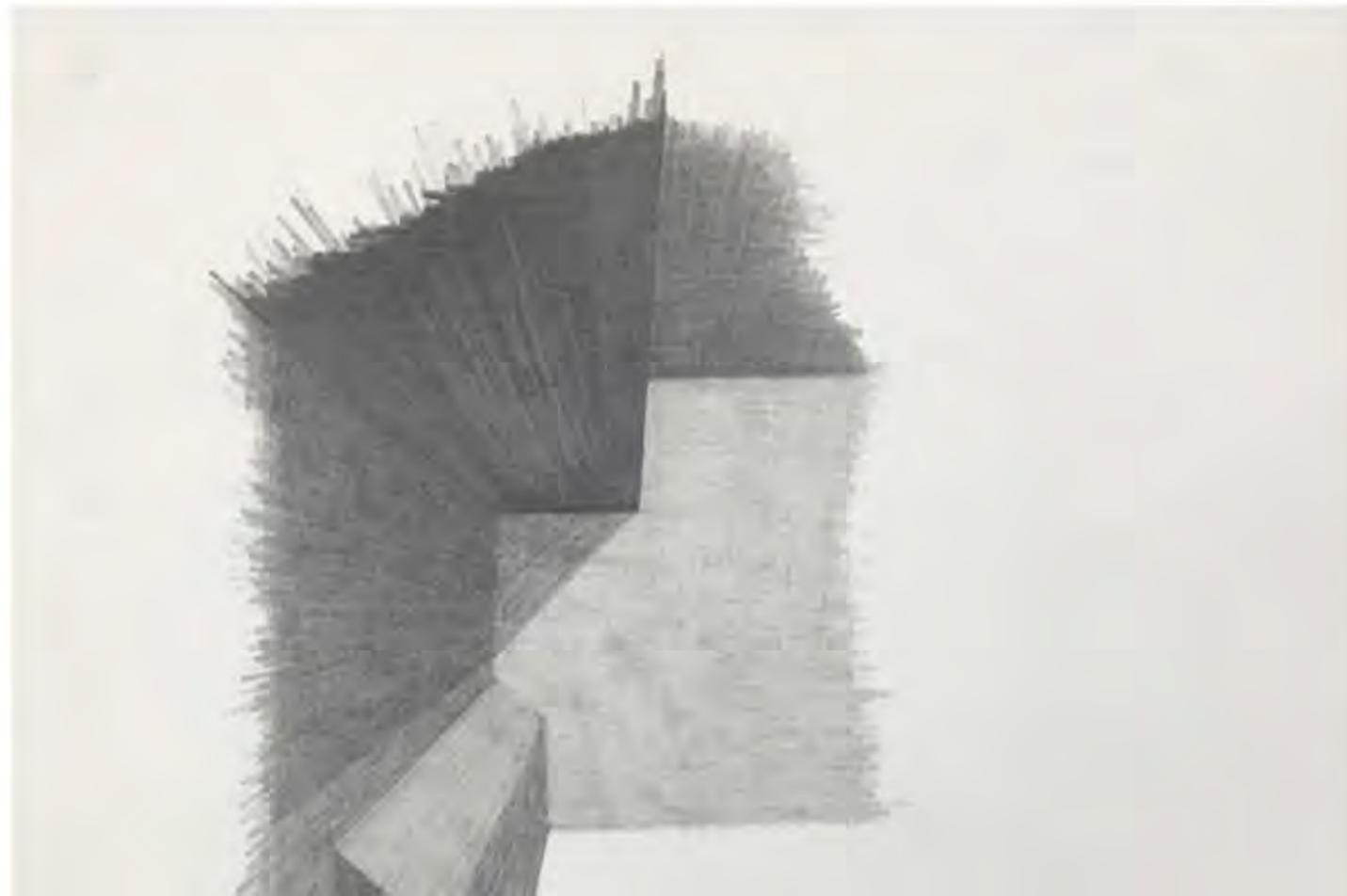

3 Different Spatial Typologies of Cruising

In the article about cruising space on the Dezeen, three different types of cruising spatial typologies are mentioned: "Spaces intended for cruising frequently adopt architectural features such as **labyrinths, nooks, recesses** to cater for hiding places and chance encounters."^[1]

After read the article, I think shouls spend some time do more research about the three different types of cruising spaces, so I can get better understanding after that I should go to Soho and try to find out the spaces with the same characteristics. Maybe I can transform these places suitable for sex?

◀ [1] Jordahn, S., 2020. Architecture Is Overdue Its Own Sexual Revolution Say Cruising Pavilion. [online] Dezeen. Available at:<[https://www.dezeen.com/2019/11/04/architecture-ove due-sexual-revolution-cruising-pavilion-ark-des/](https://www.dezeen.com/2019/11/04/architecture-ove-due-sexual-revolution-cruising-pavilion-ark-des/)> .

17.02.2019:

3 Different Spatial Typologies of Cruising

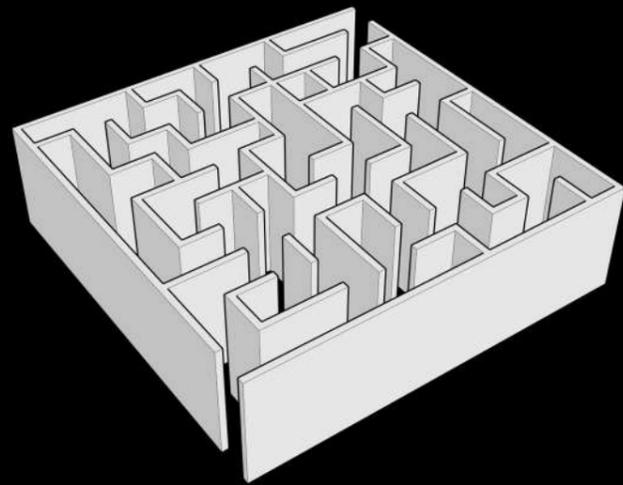

Labyrinth

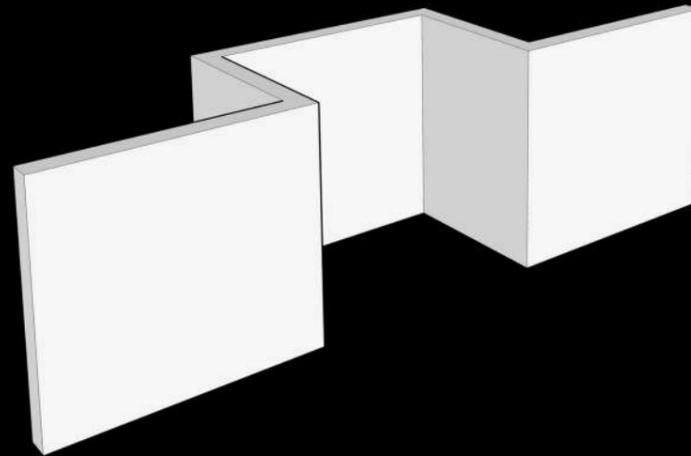

Recesse

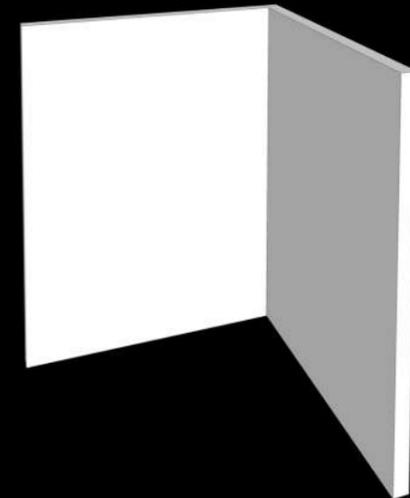

Nook

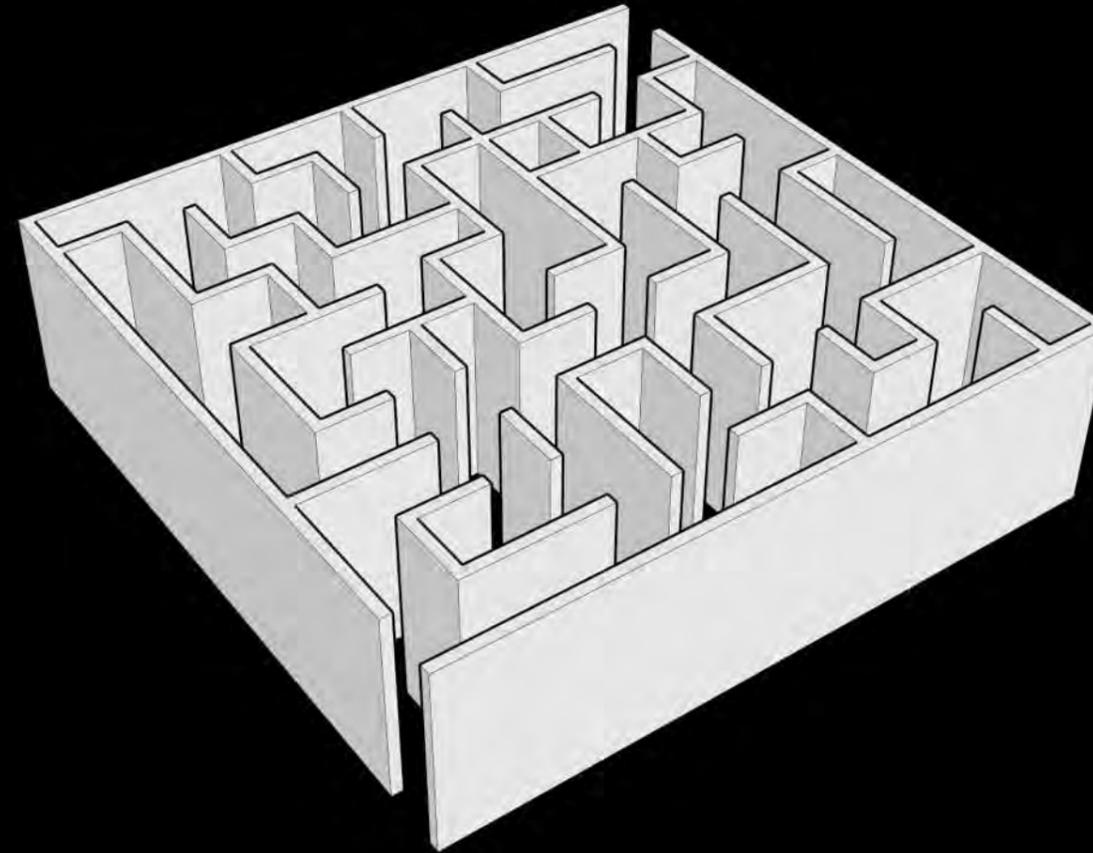

Labyrinths

Features: **Anti-modernist**

Perrault: "It uses several anti-modernist spatial strategies. It embraces the labyrinth, the maze and darkness as an architectural device which is precisely what has been eradicated for the last 300 years by all sorts of architecture whether public or private."^[2]

Advantages:

1. "For me, the labyrinth is a device that can be protective and an escape from heteronormativity," said Perrault. ---A good **protection** and **concealment**
2. Exciting: It turns sex into an **adventure**

[2] Block, I. (2020). Cruising Pavilion aims to show how sex "is always latent or silenced" in architecture. [online] Dezeen. Available at: <https://www.dezeen.com/2018/05/30/cruising-pavilion-veice-architecture-biennale-2018-casual/> [Accessed 2 Mar. 2020].

Labyrinths

Perrault: "For basically the last 200 or 300 years of architecture, the maze was to be avoided as a form linked to immorality," he explained. "Everything had to be ordered, placed, named, oriented, because that's what made the city safe, controllable, surveilled, efficient and productive."

Embracing labyrinthine layouts then becomes a radical act, inspiring "architecture that is not only about constructing gender and relationships, but actually liberating".^[3]

[3] Block, I. (2020). Cruising Pavilion aims to show how sex "is always latent or silenced" in architecture. [online] Dezeen. Available at: <https://www.dezeen.com/2018/05/30/cruising-pavilion-veice-architecture-biennale-2018-casual/> [Accessed 2 Mar. 2020].

17.02.2019:
About Labyrinth

EVERY HOLE IS A GOAL

A Cruising Labyrinth,
made from 32 sheets of 244x122 cm
Hardboard, painted black.



Hey Andreas,

Hope you made it back safe and sound.

I'm about to sign the deal for the night and announce the party. How long do you think you need to come up with some sketches...? For our mini-labyrinth + dick deck? X

Hey Danny, have a look. should be easy to build and affordable, and hopefully sexy too SA

Thanks Andreas! I like the minimalism and repetition.

If I could change one thing, I would play with the holes a bit, like make some bigger, some smaller, position some up like peep-holes for Peeping Toms, position some lower for short-legged guys who want a suck too. So it becomes more like a giant piece of black Swiss cheese. X D.

cruising labyrinth was designed for a **BUTT** magazine party in 2011. **Feel Old Yet?**

MAKE YOUR OWN

when you order online



vs when it arrives

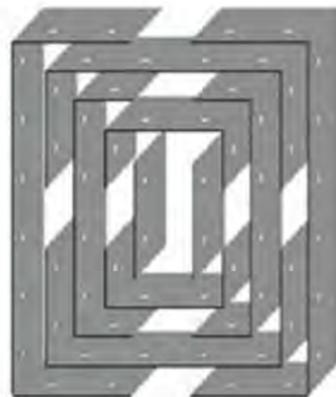

Steps at front create a Dick Deck, a Sucking Station. The holes in front of the steps should be drilled at 112 cm height, and each step should be 16cm.



The perfect butthyritrh doesnt exi...

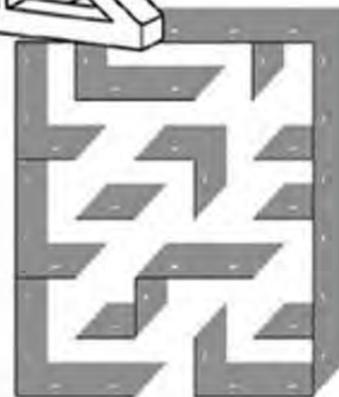
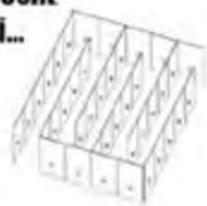

Precedent- Cruising Labyrinth

'Artist Andreas Angelidakis' Cruising Labyrinth, an "IKEA-style" flatpack comprising panels of prefabricated black-painted plywood that can be arranged by the user to create a maze leading to the pinnacle of anonymous sex, the glory hole.'

On one hand, I think the expression of this precedent is a bit too straightforward. I do not think I can use this kind of design form in my project, but on the other hand, I like the design that the users can adjust the space according to their own needs. A flexible space, that is very cool.

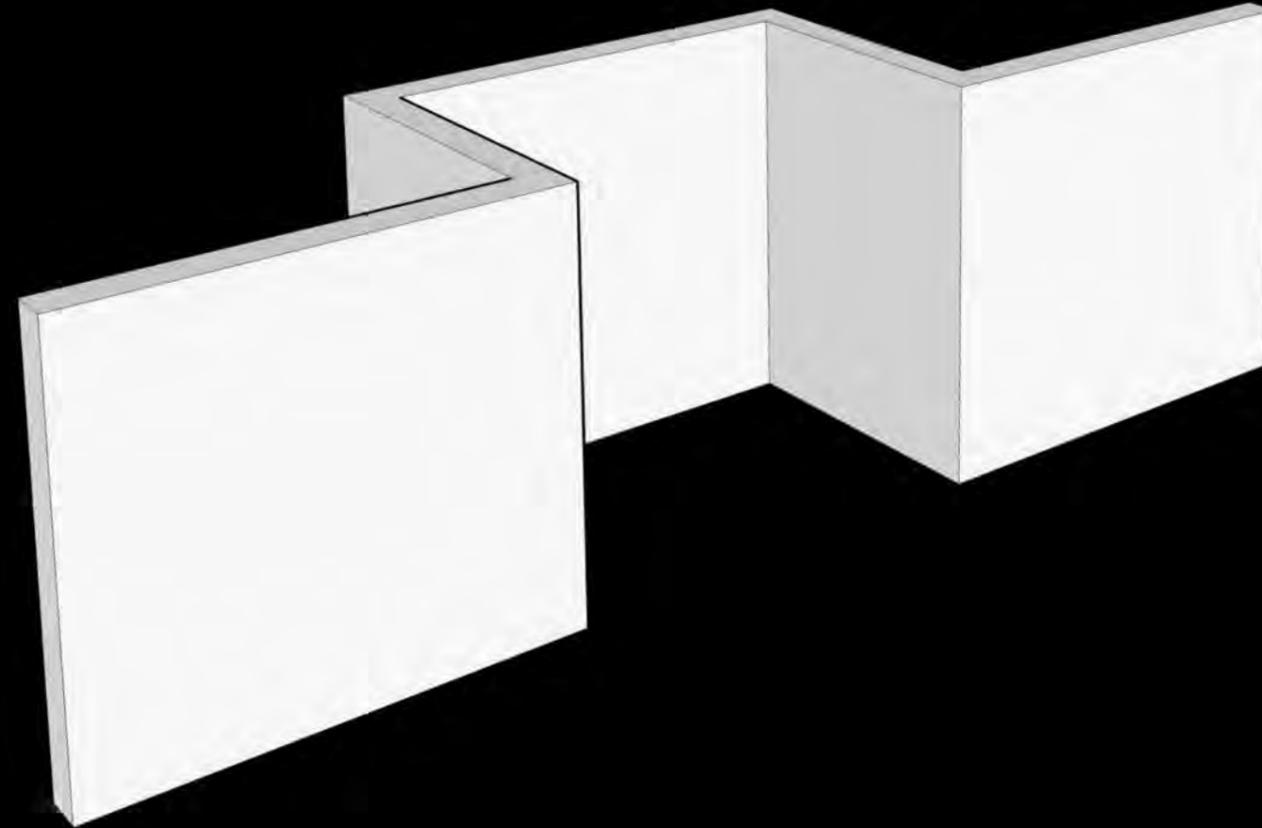

Recesses

Features and Advantages:

Recesses are the most **common** type of space suitable for 'cottaging' in the Soho area, and they are usually located at the fire exit of buildings. The advantage of this spatial structure is that **it allows the user to observe passersby without being seen.**

17.02.2019:

Recesses---Similar types of spaces I found in Soho

There are a lot of similar spatial structures in Soho area, and they are mainly the fire exit behind the stores or theaters. In many fire exits, I chose the following ones because they meet the following characteristics:

1. There is no CCTV camera nearby
2. Are not be used frequently
3. The space is large enough (at least able to accommodate two people)



Some 'recesses' I chioce in Soho that suitable to change into 'cottage'.

16.03.2019:

The last face-to-face tutorial

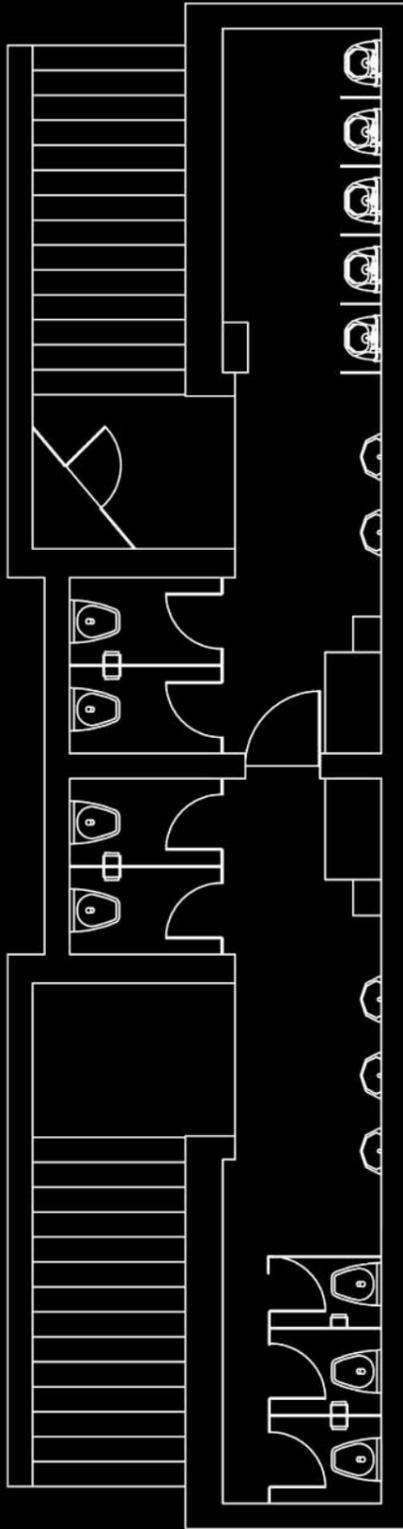

Existing toilets plan

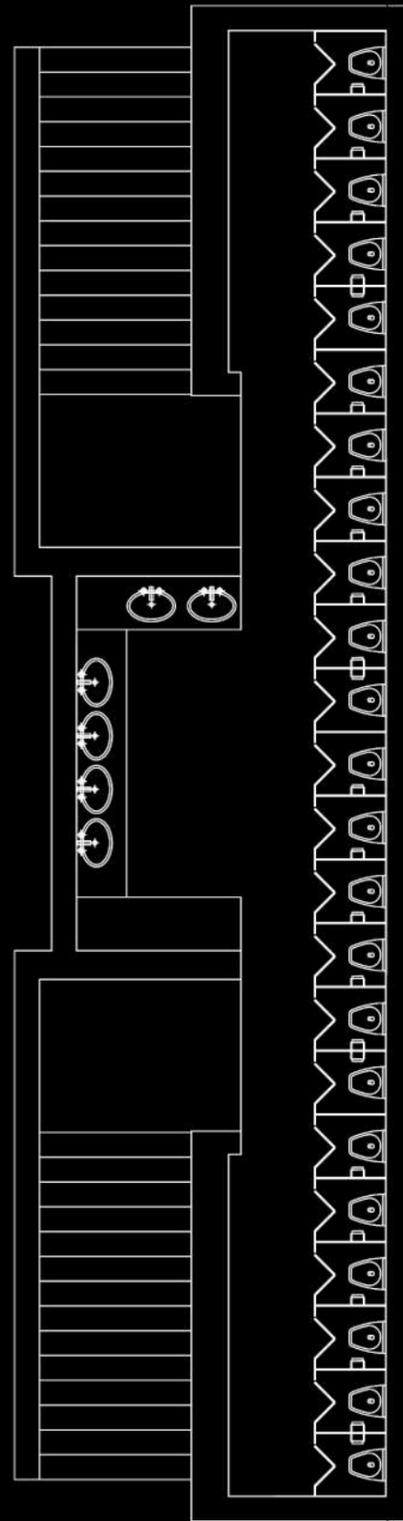

Unisex toilet design proposal plan

Do more research about unisex toilet

The main Feedback for further development:

1. Do more research about unisex toilet, see what should a good unisex toilet have? Write down and draw sketches to show what you learned from these precedents.
2. Look at the regulations to check the requirements for the number of sinks in the public toilet.
3. There is no need to keep two existing stairs.

17.03.2019:
Do more research about unisex toilet

KEY IDEAS FROM PRECEDENTS

1. Function organization---What functions should a perfect unisex toilet have?



2. What a perfect wheelchair accessible cubicle/ Caregiving room should look like.

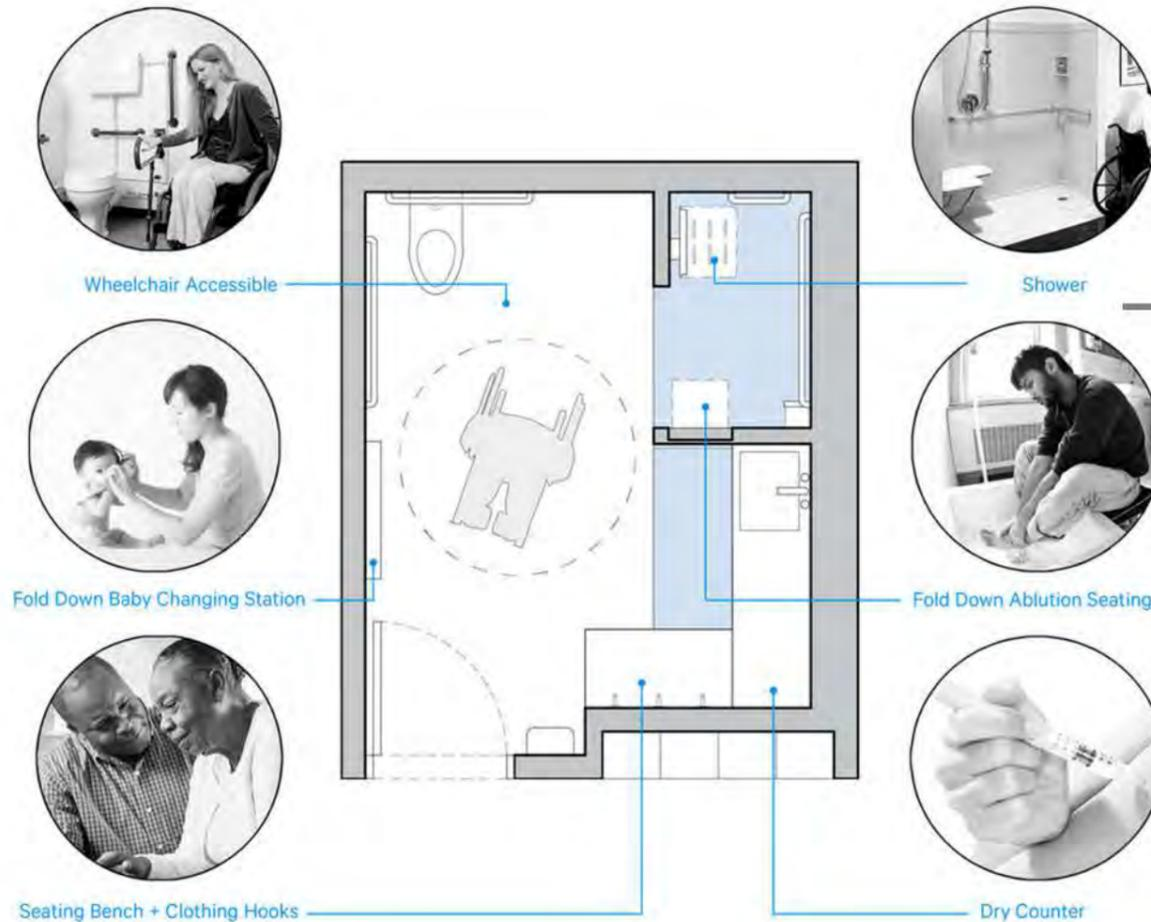

INCLUSIVE:

A shower that also allows Muslims to perform ablutions.



17.03.2019:

Do more research about unisex toilet

3. different needs of different user groups (from 'Stalled' website)

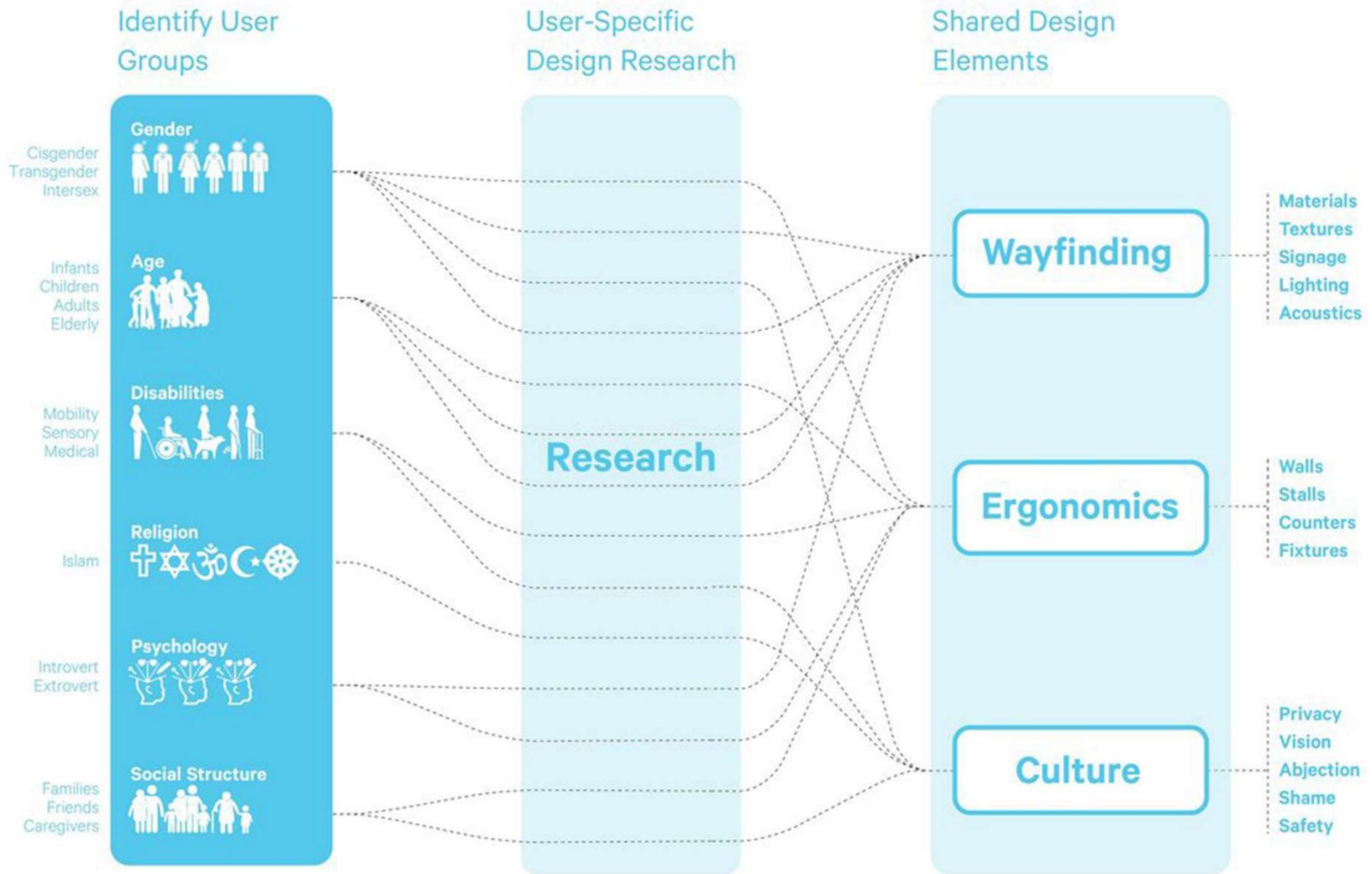

17.03.2019:

Do more research about unisex toilet

KEY IDEAS FROM PRECEDENTS ---Rohan Chavan's public toilets aim to provide a safe socialising space for women



- 1.what a toilet can be?
- 2.light

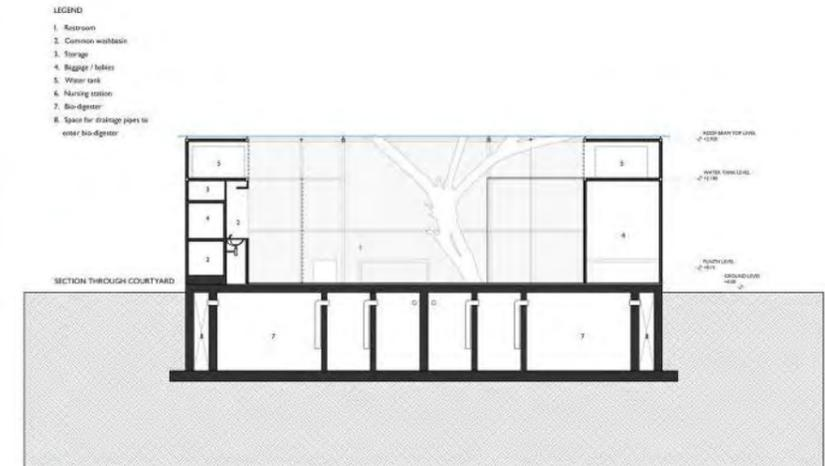

"Public spaces in a city are important [places] where people meet and interact," said Chavan. "It is a place of mental interaction where new ideas are born."

The space also includes vending machine for female hygiene products, as well as mobile phone charging points, a panic alarm system and room for the future inclusion of a cash machine.

These public toilets by architect Rohan Chavan are built around an old tree in the Indian city Thane, and include a hot-pink sitting area where women can socialise (+ slideshow).

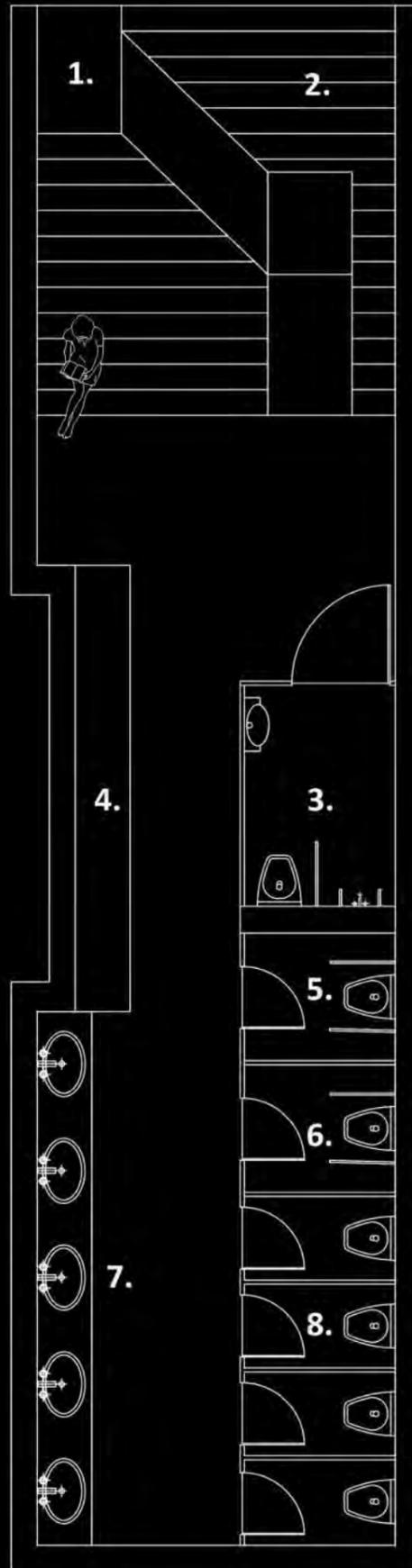

- 1. Wheelchair ramp
- 2. Stairs & resting space
- 3. Wheelchair accessible cubicles/shower/ caregiving room
- 4. Grooming station
- 5. Ambulatory cubicles
- 6. Ambulatory cubicles
- 7. washing station
- 8. Standard cubicles

The new design proposal plan: Based on the study of precedents, more factions have been added

In the new floor plan tried to add a wheelchair accessible ramp for disabled people, just like the precedent in the picture below. In this way, the entrance of the toilet can be used by different user groups, and can also be used as a resting area for people. At the same time inside the toilet, I also tried to add different functions (like shower / caregiving room...) according to the previous precedent.



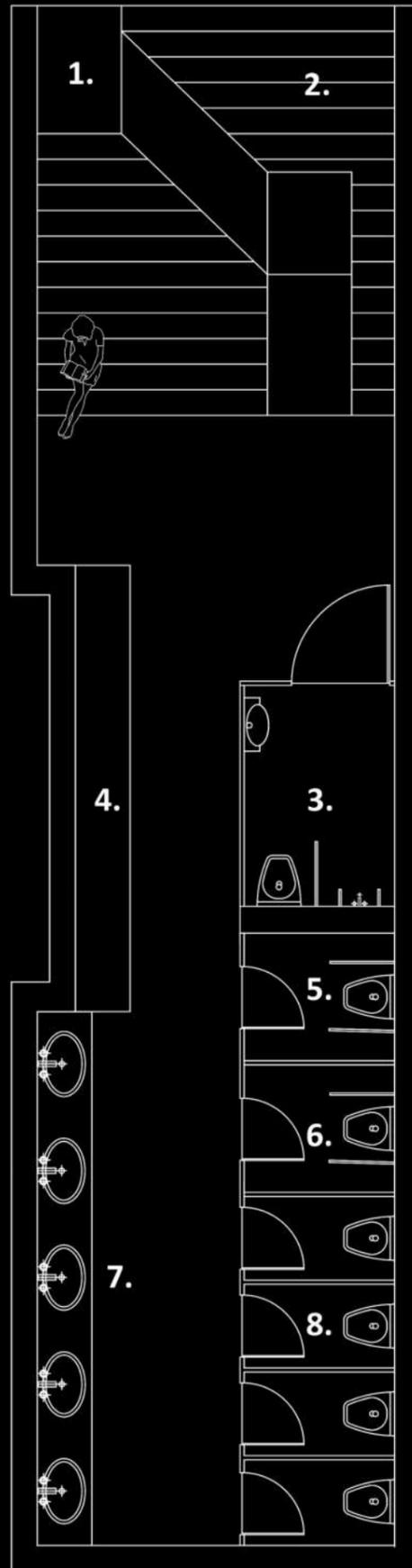

1. Wheelchair ramp
2. Stairs & resting space
3. Wheelchair accessible cubicles/shower/ caregiving room
4. Grooming station
5. Ambulatory cubicles
6. Ambulatory cubicles
7. washing station
8. Standard cubicles

Continue to improve the floor plan of unisex toilet

The main Feedback for further development:

1. Look at regulations, show people what the different types of toilet cubicles look like.
2. There is still a lot of space inside the toilet to place another cubicle.
3. The shower function in the public toilet is not necessary.
4. Resting area: No one wants to sit on the stairs of a public toilet, maybe it will be better to put the resting area on the ground floor like the Indian precedent.
5. Considering where to put the disabled cubicle? Above ground or underground? Tell people why?
6. The wheelchair ramp is not working now, check the ramp ratios in the regulations, it should be like 1:12

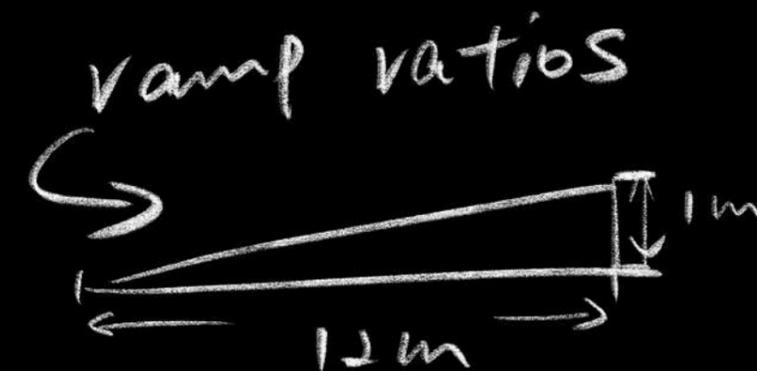

1. Function organization---What functions should a perfect unisex toilet have?

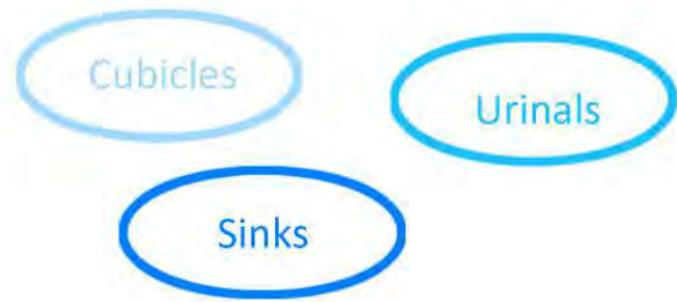

Main Functions of existing toilets



Main Functions a good uni-sex toilet should have

2. Different kind of cubicles in regulations:

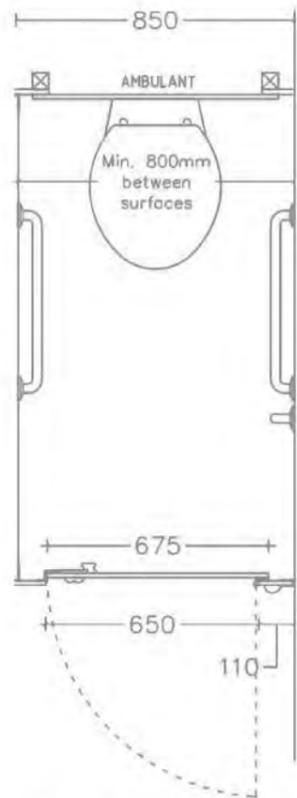

mbulant cubicle

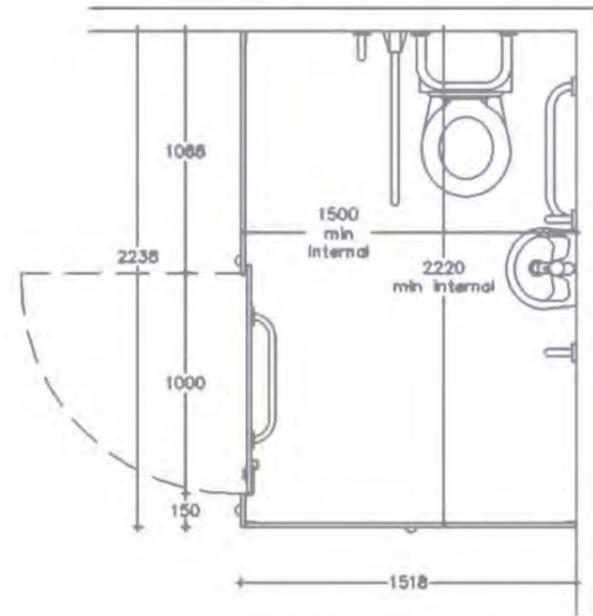

Wheelchair accessible cubicle

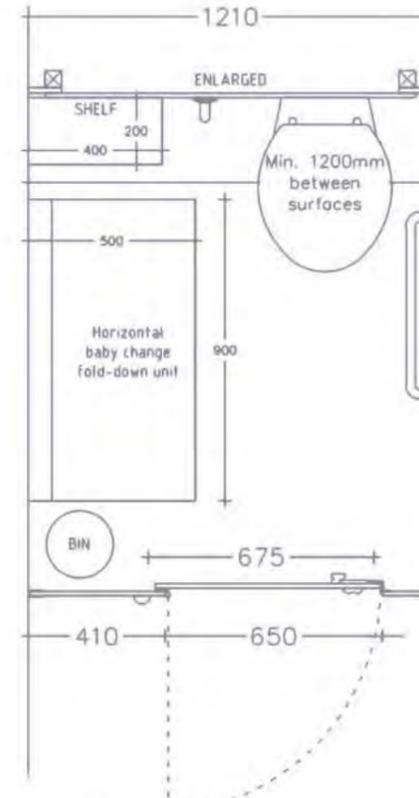

Enlarge cubicle

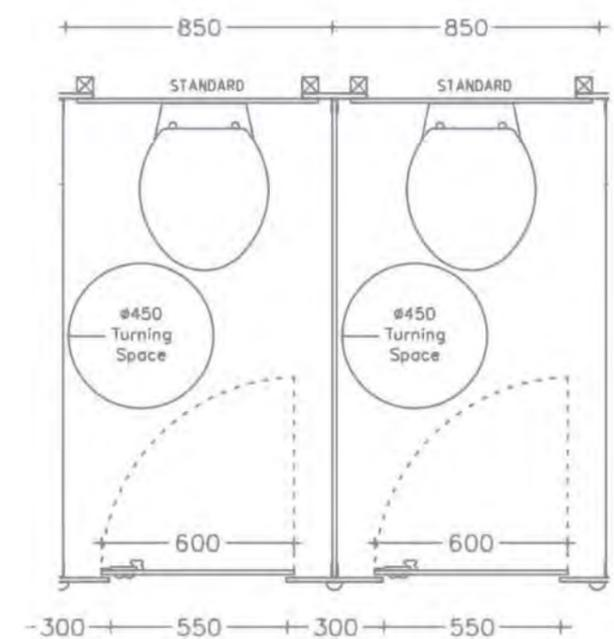

Standard cubicles

22.03.2019:

Improve the unisex floor plan

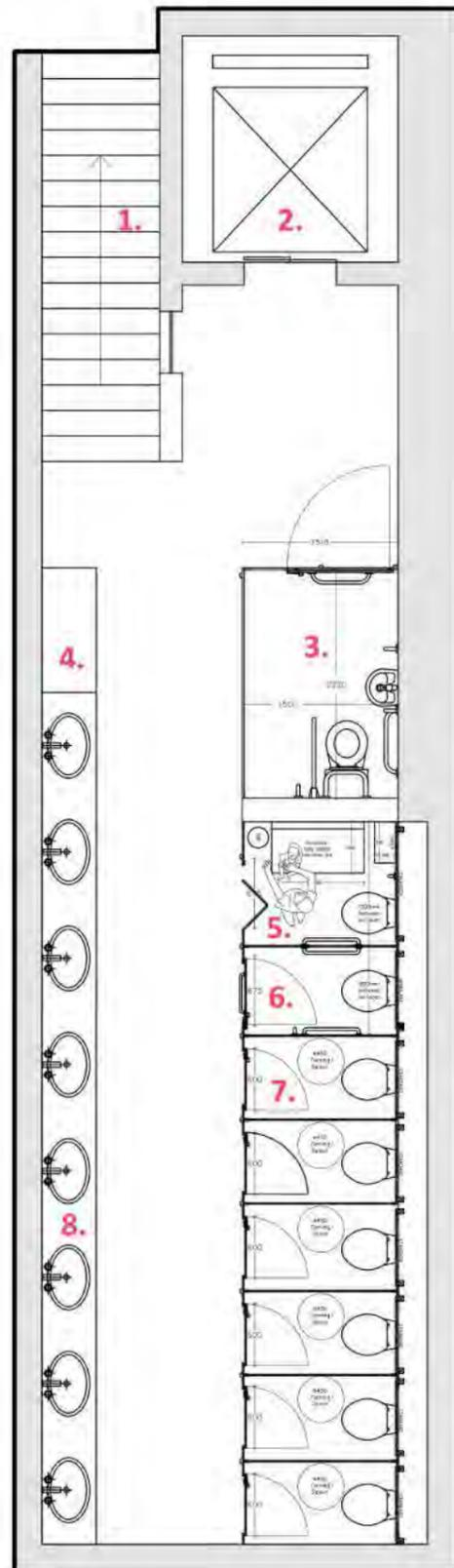

1. Stairs
2. Elevator
3. Wheelchair accessible cubicles
4. Grooming Area
5. Caregiving room/Ambulatory cubicle
6. Ambulatory cubicle
7. Standard cubicles
8. Sinks

Improve the unisex toilet plan

Based on last week tutorial feedback, i changed the unisex toilet plan:

1. Deleted the shower function in the old plan.
2. Deleted the resting area and move it to the ground floor.
3. Decided to put the disabled cubicle underground and changed the wheelchair ramp on the old plan to a more accessible and space-saving wheelchair accessible lift.
4. Checked the regulations and changed all kind of cubicles into the right size.



Tried to move the resting area to ground floor

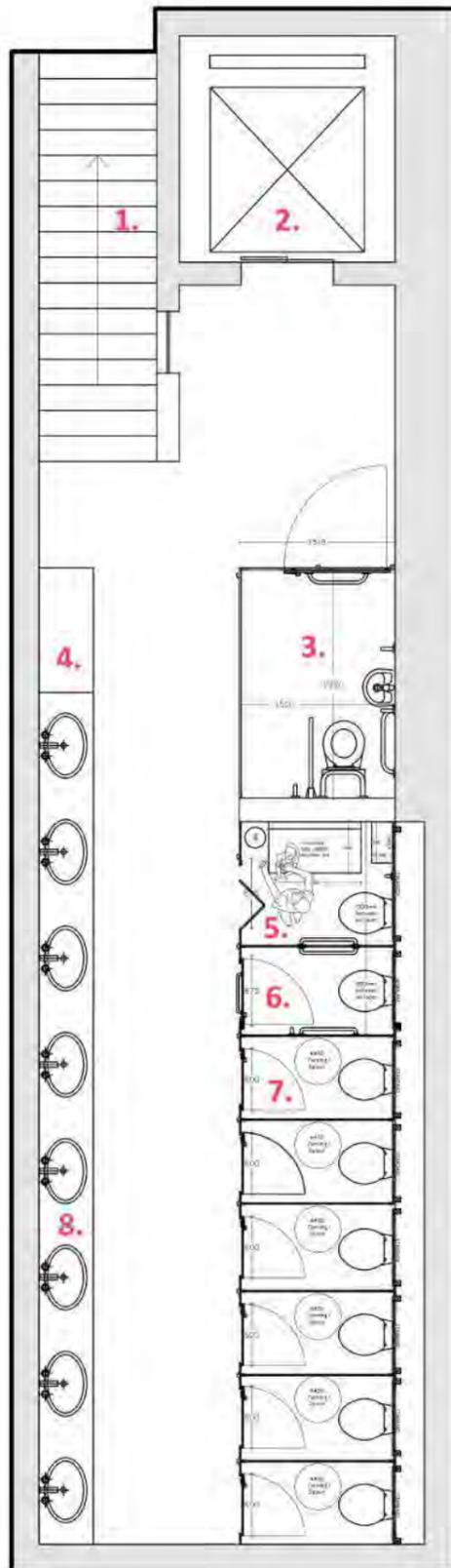

- 1.Stairs
- 2.Elevator
- 3.Wheelchair accessible cubicles
- 4.Grooming Area
- 5.Caregiving room/Ambulatory cubicle
- 6.Ambulatory cubicle
- 7.Standard cubicles
- 8.Sinks

Progress is slower than expected

During the tutorial Kevin told me that my working progress is slower than expected, in this week I should already finished the unisex toilet design part and start design the 'cottage' part...So before next tutorial I need finish the following works:

1. Change wall thickness in old Existing plan and Correct the water tank part

2. Change the elevator in the unisex toilet plan into a smaller one

Drawings to be completed:

3. Existing ground floor plan (male +female)

4. Existing basement plan

5. Existing section (male +female)

6. Design proposal-ground floor plan

7. Design proposal- basement plan

8. Sketch of 'cottage' (just like the precedent I showed today, with 5 different precedents on top+ design proposal)

24.03.2019:

Working on existing toilets plan

1:150 Ground floor Plan
Existing Part

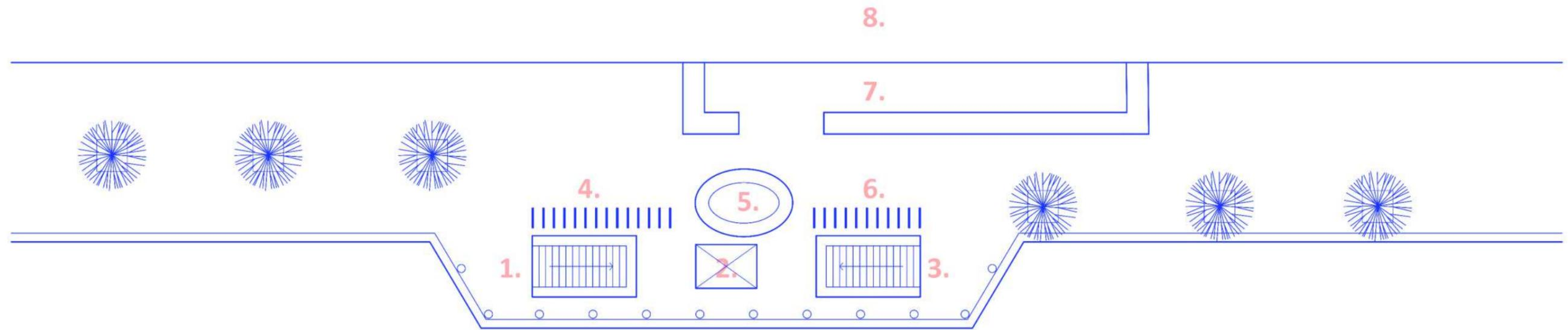

- 1. Female toilet entrance
- 2. Ventilation equipment
- 3. Male toilet entrance
- 4. Bicycle racks

- 5. Disabled toilet
- 6. Bicycle racks
- 7. Restaurant outdoor dining area
- 8. Restaurant entrance

24.03.2019:

Working on existing toilets plan--- Basement plan

1:50 Basement Plan
Existing Part

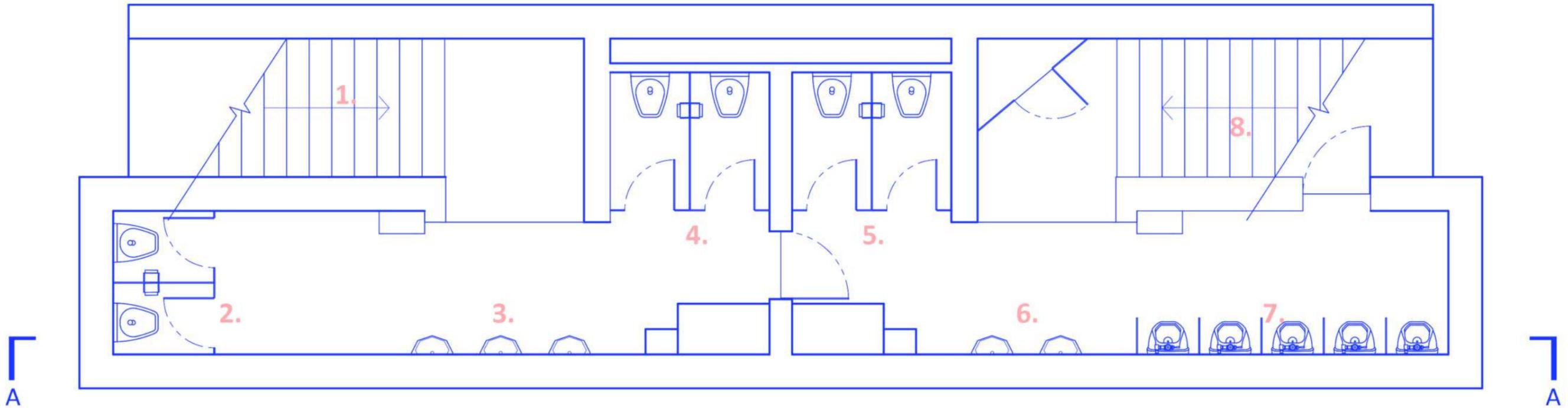

- | | |
|---------------------------|-------------------------|
| 1. Female toilet entrance | 5. Cubicles |
| 2. Cubicles | 6. Sinks |
| 3. Sinks | 7. Urinals |
| 4. Cubicles | 8. Male toilet entrance |

24.03.2019:

Working on existing toilets plan--- built the existing toilet sketchup models

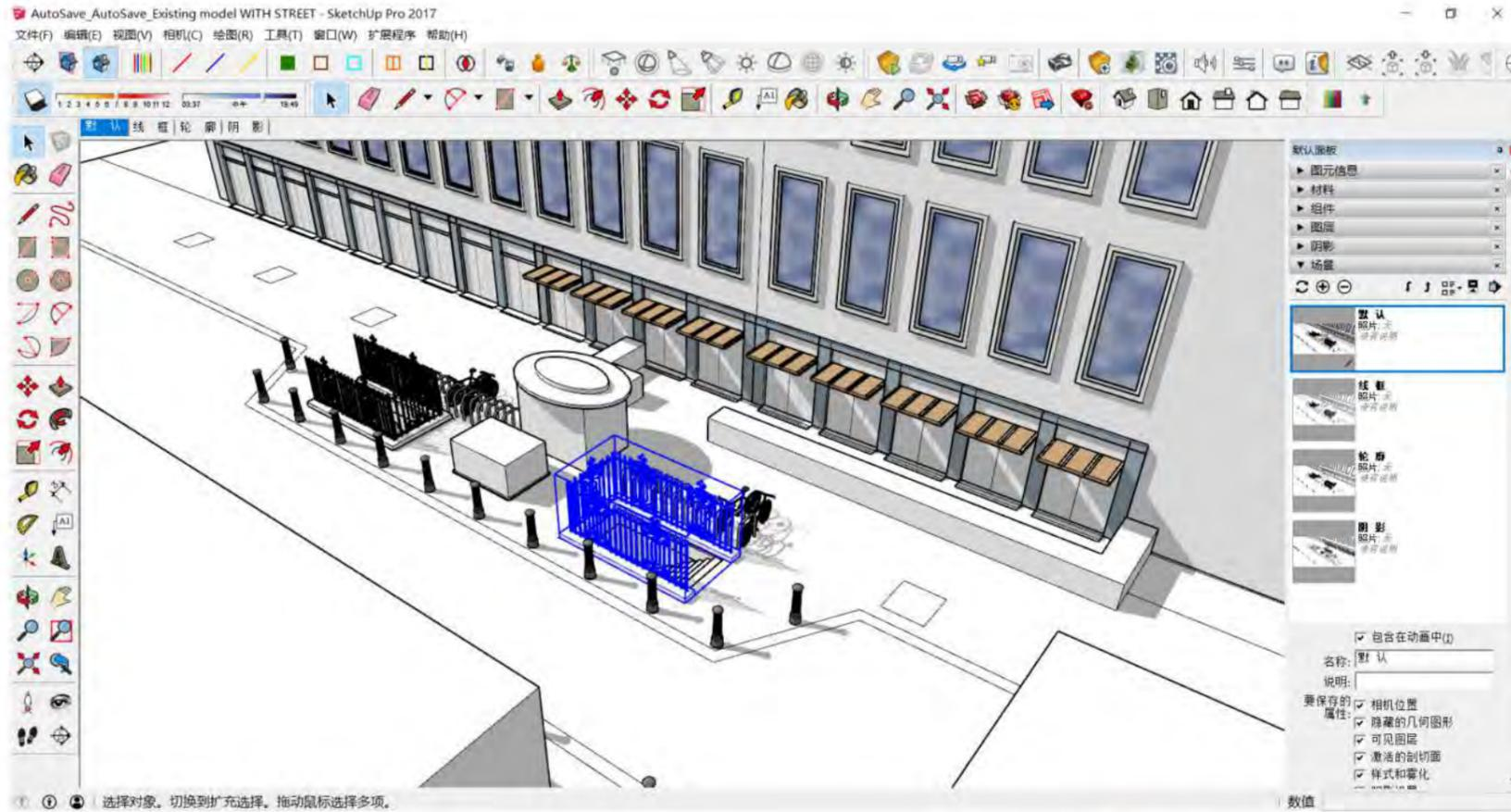

◀ Built the existing ground floor model from the CAD plan I drew.

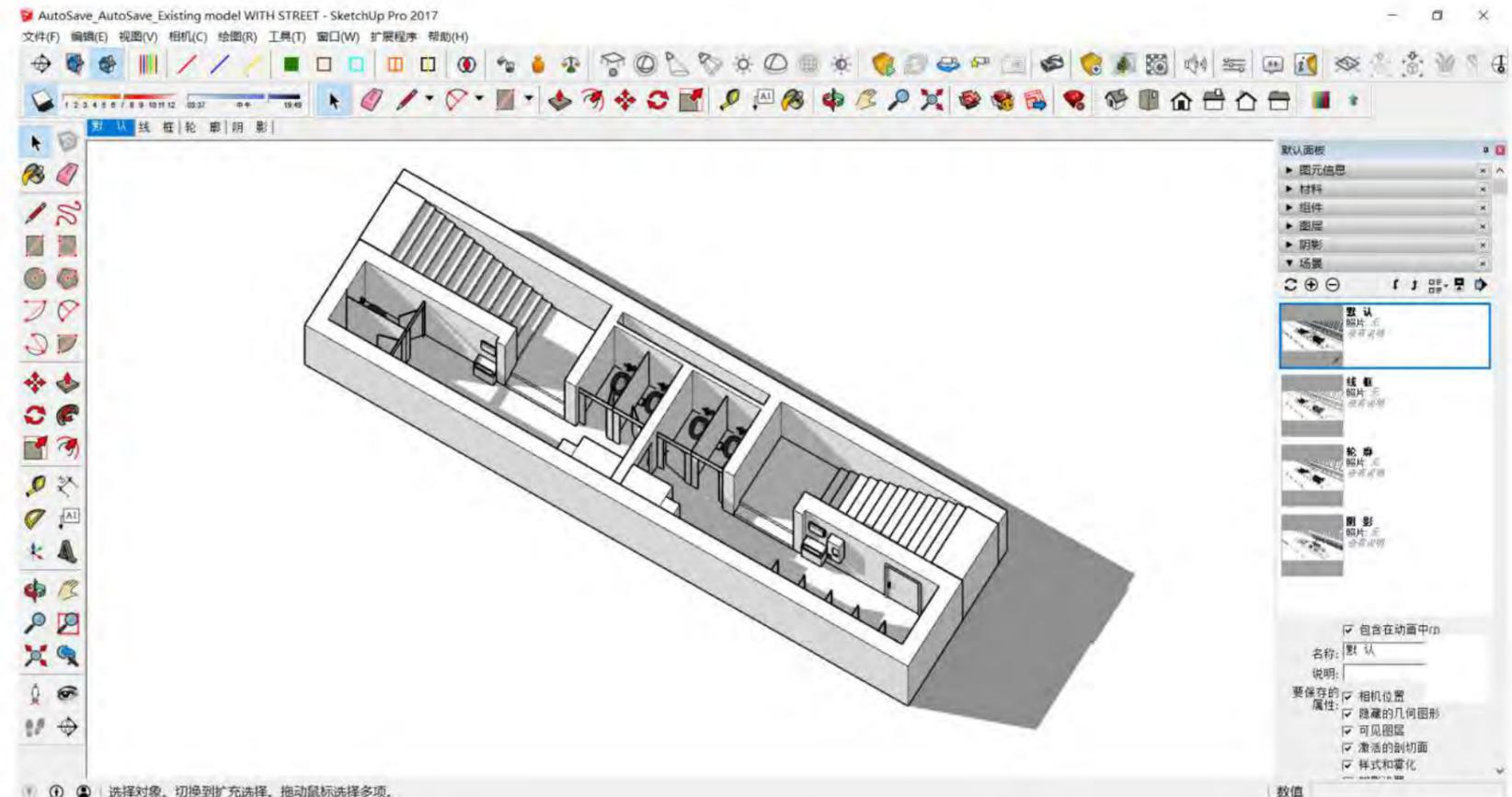

The basement model ▶

24.03.2019:

Working on existing toilets drawings

I blurred the building on the ground floor and superimposed it on the drawing of the basement, trying to express the relationship between the upper and lower floors.

