

Vertical Street

Issey Fang

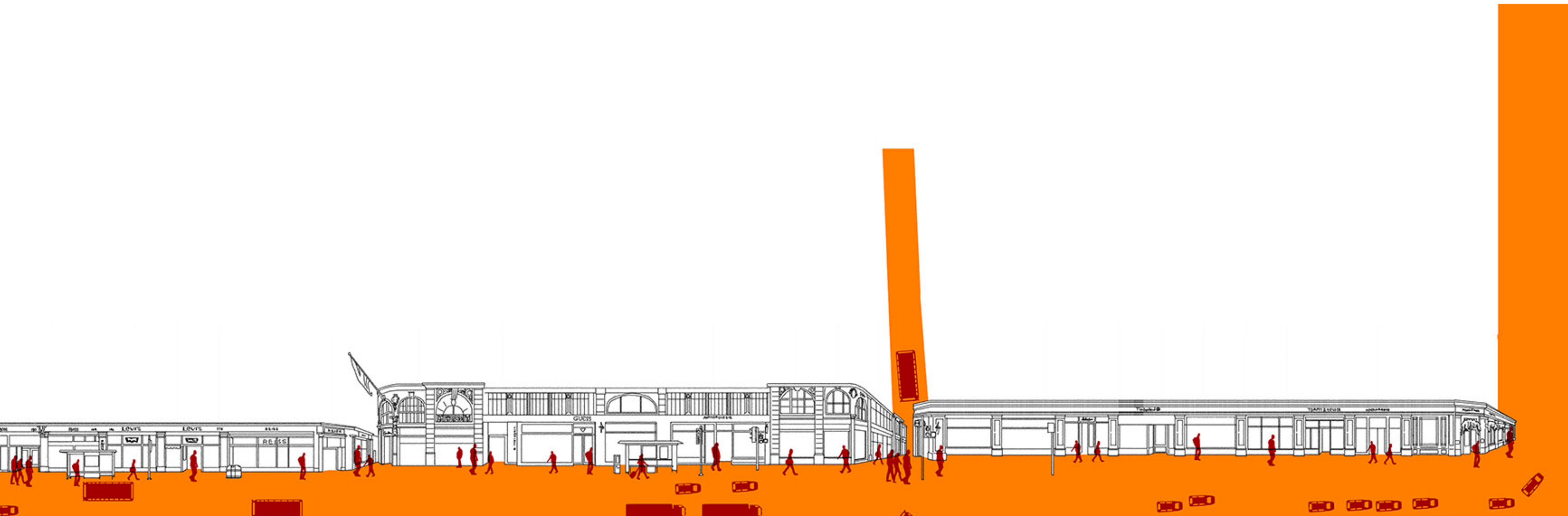

Vertical Street

Issey Fang

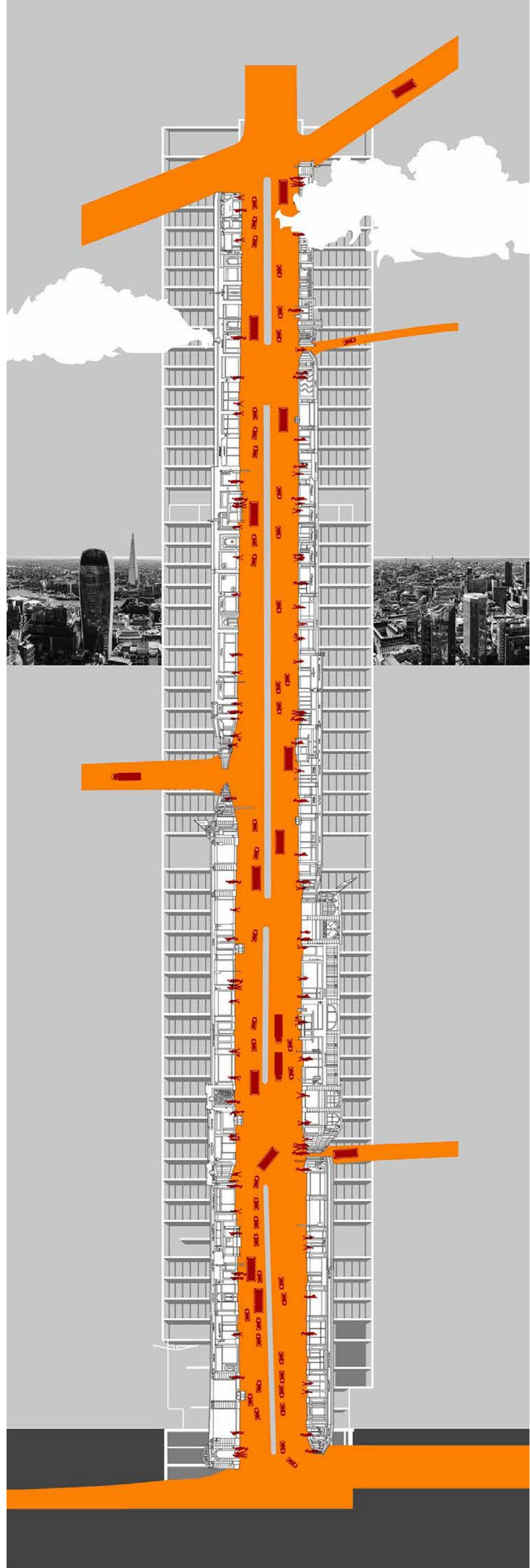

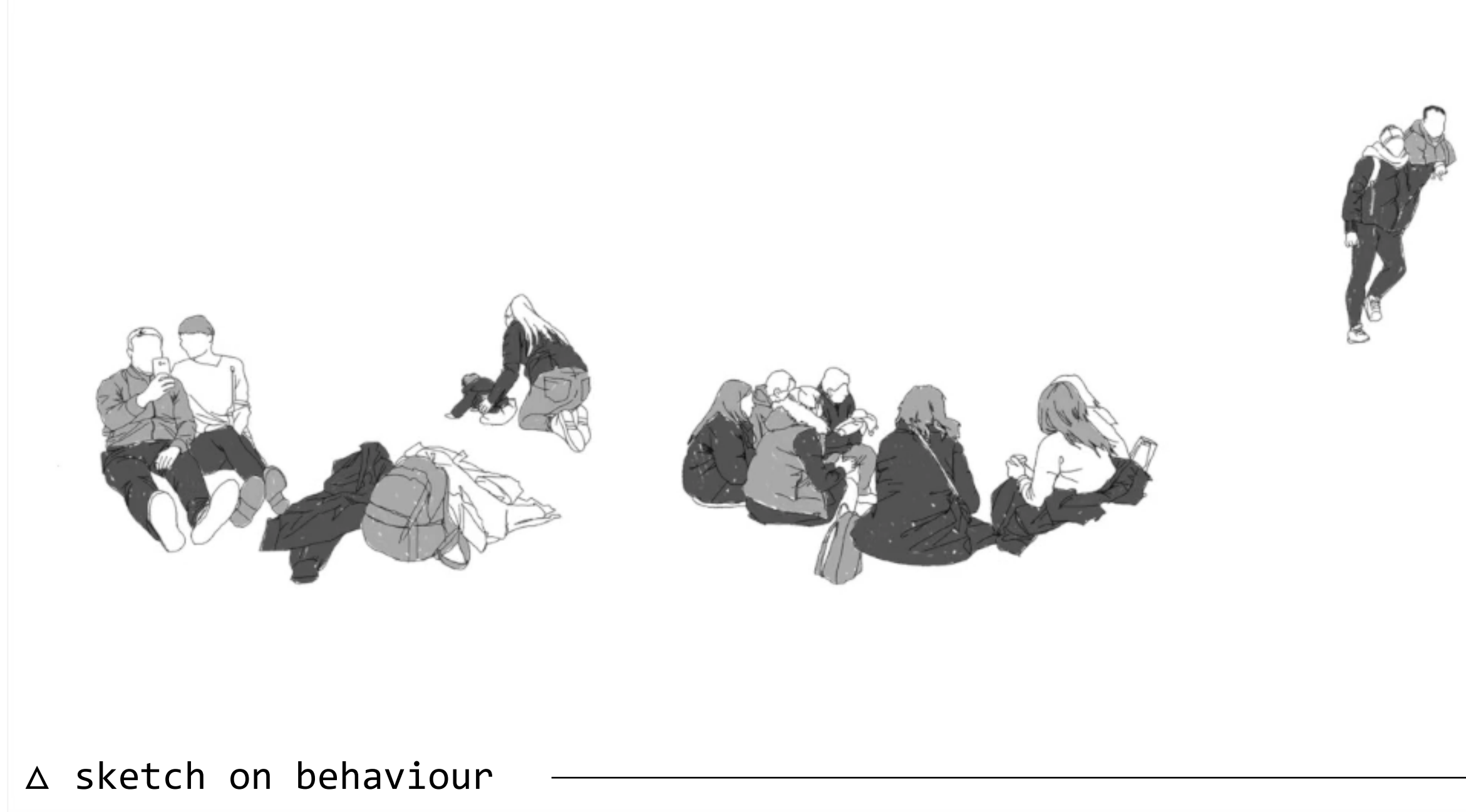
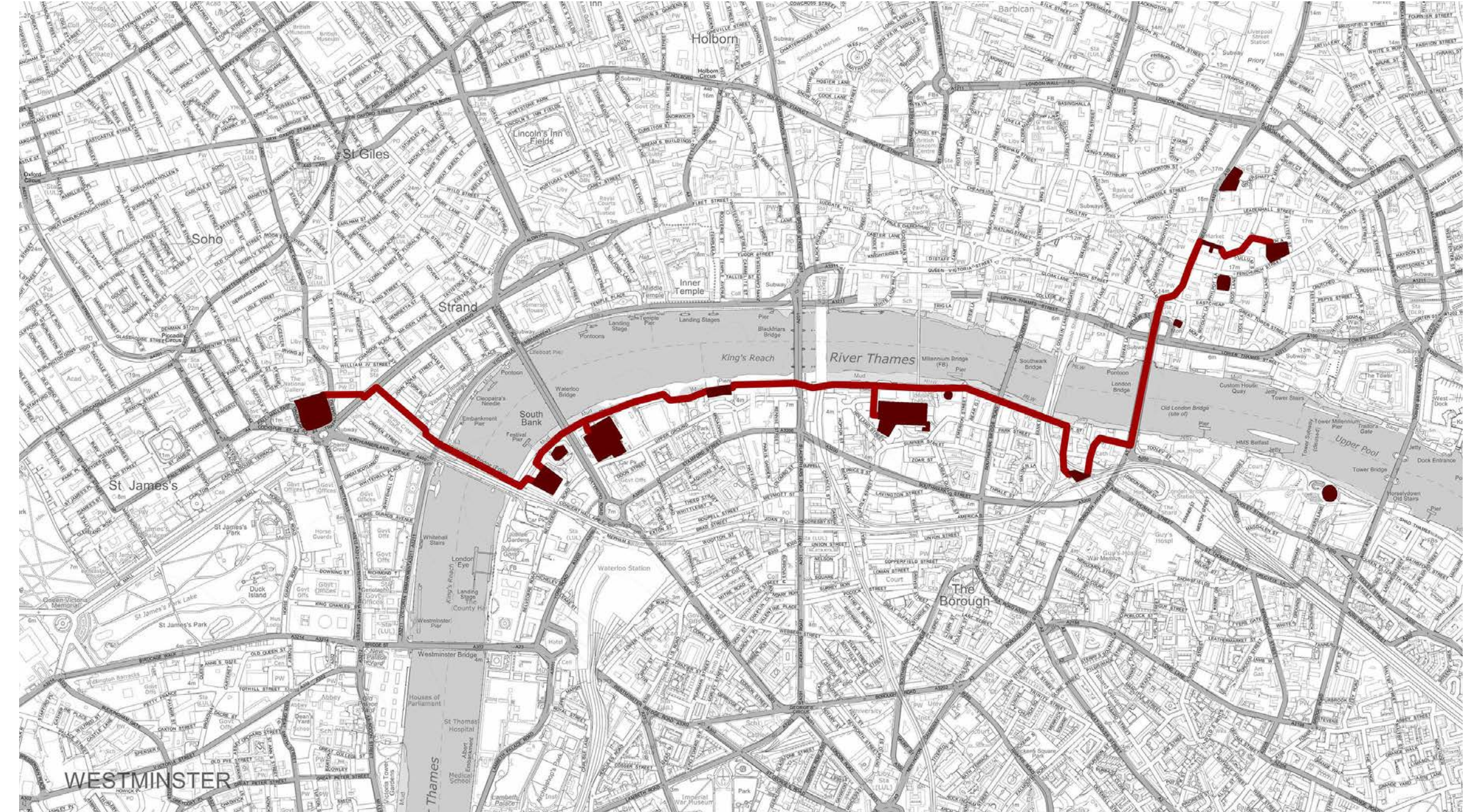

△ sketch on behaviour

△ investigation trip

Behaviour Study :Research

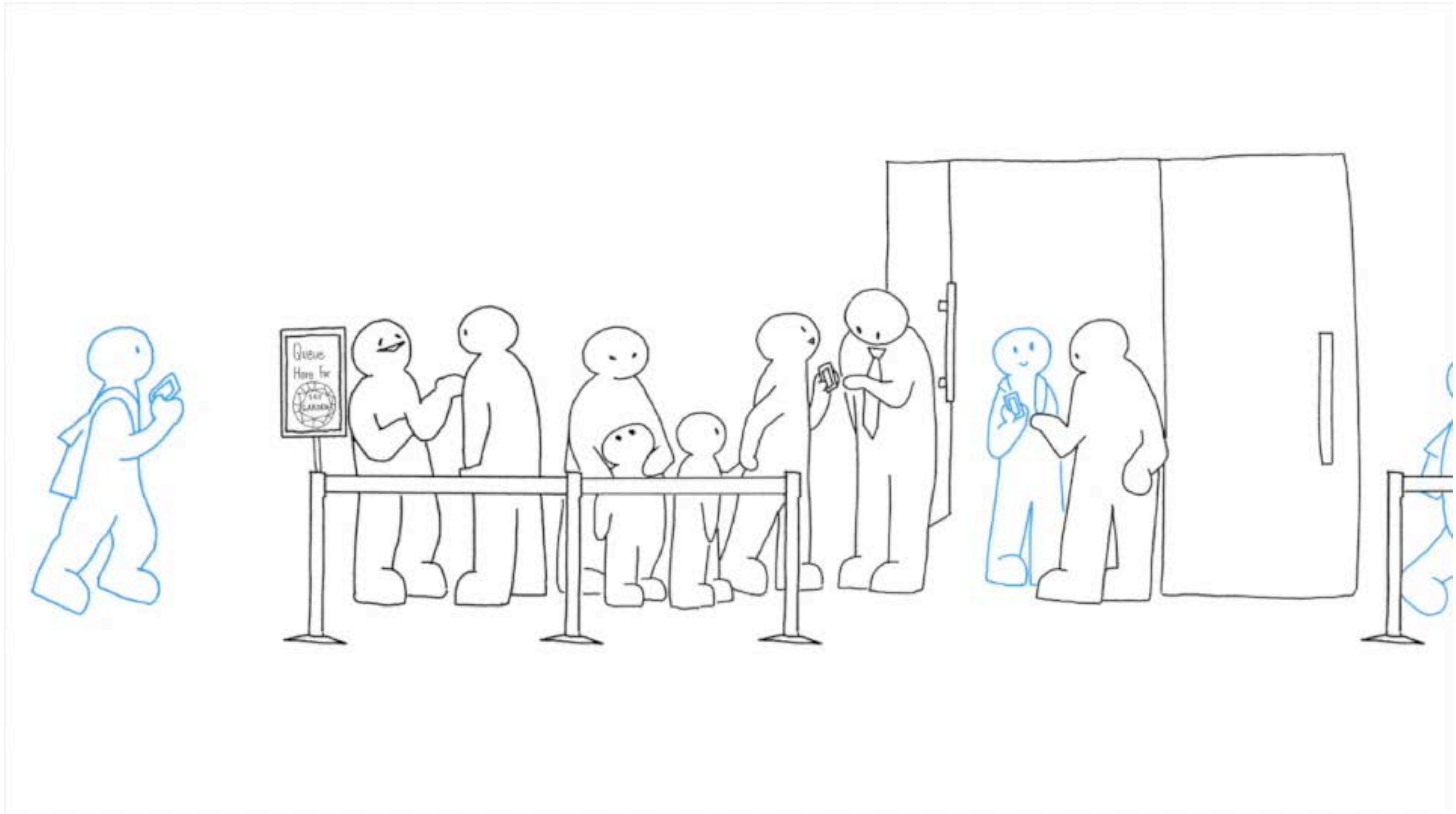

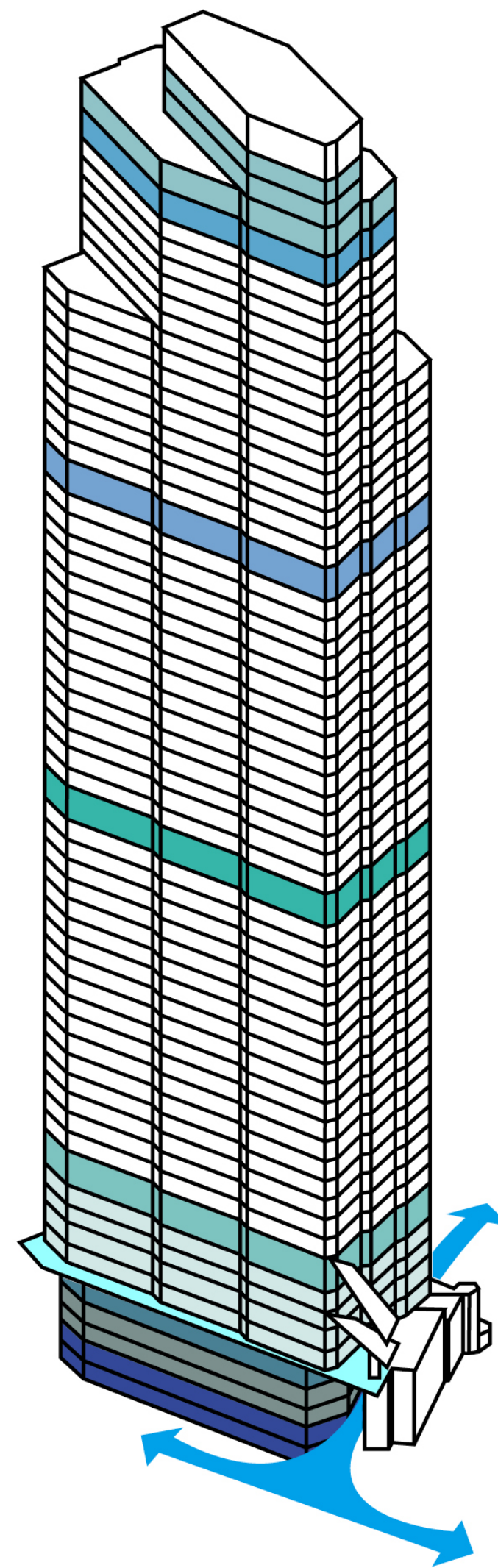
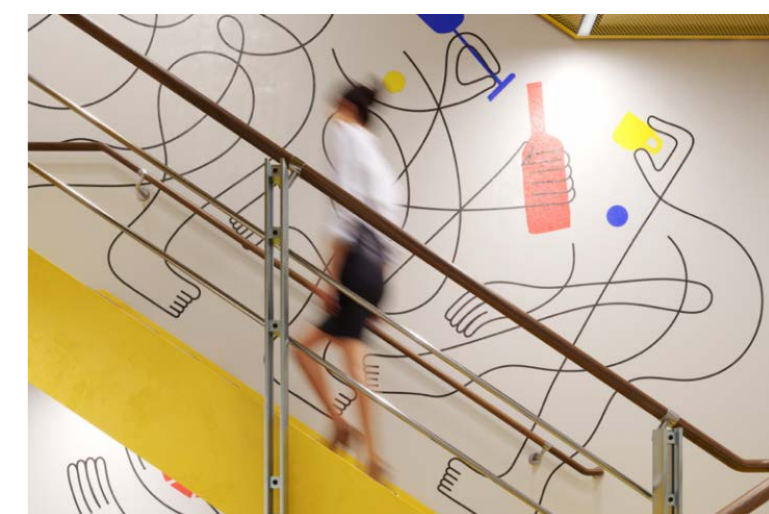

- 58-60 The viewing gallery
- 57 The club
- 42-56 The office
- 41 The retreat
- 40-26 The office
- 25 The gym
- 08-24 The office
- 07 The exchange
- 03-06 Space on demand
- 02 The market
- 00 The lobby
- 01/02 The bike park
- Wind mitigation canopies
- Pedestrian access

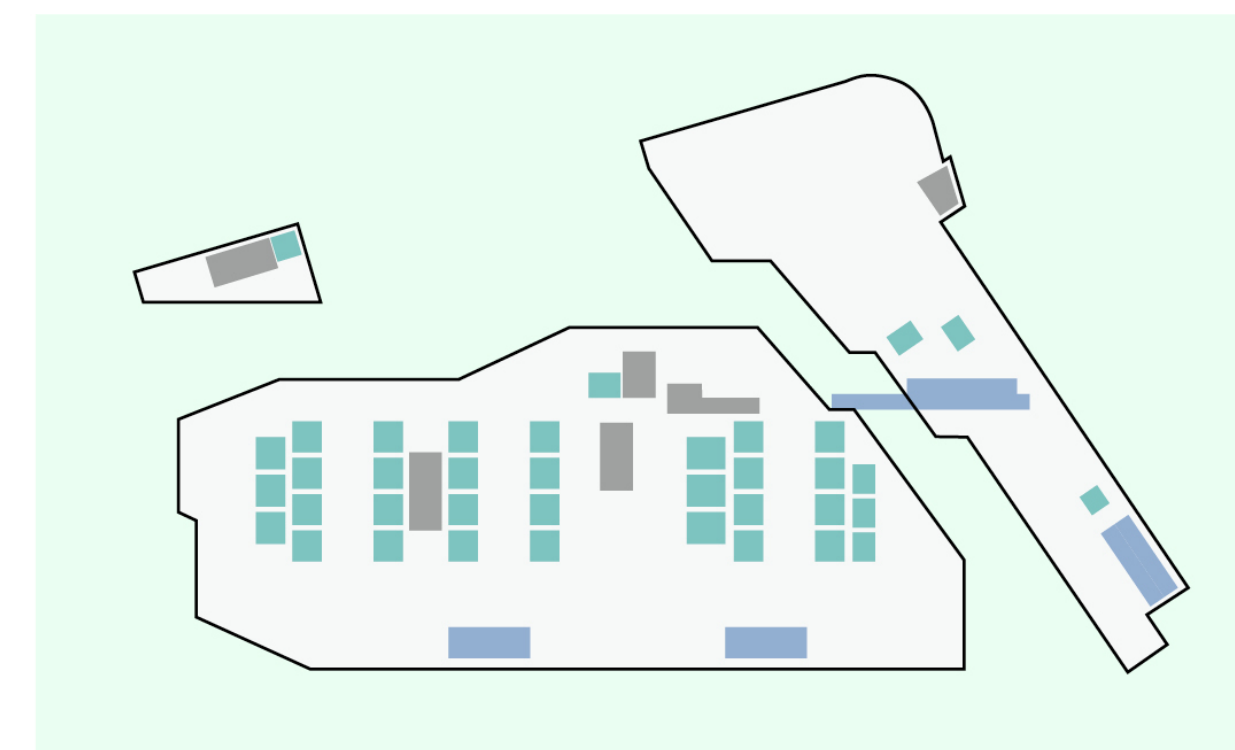
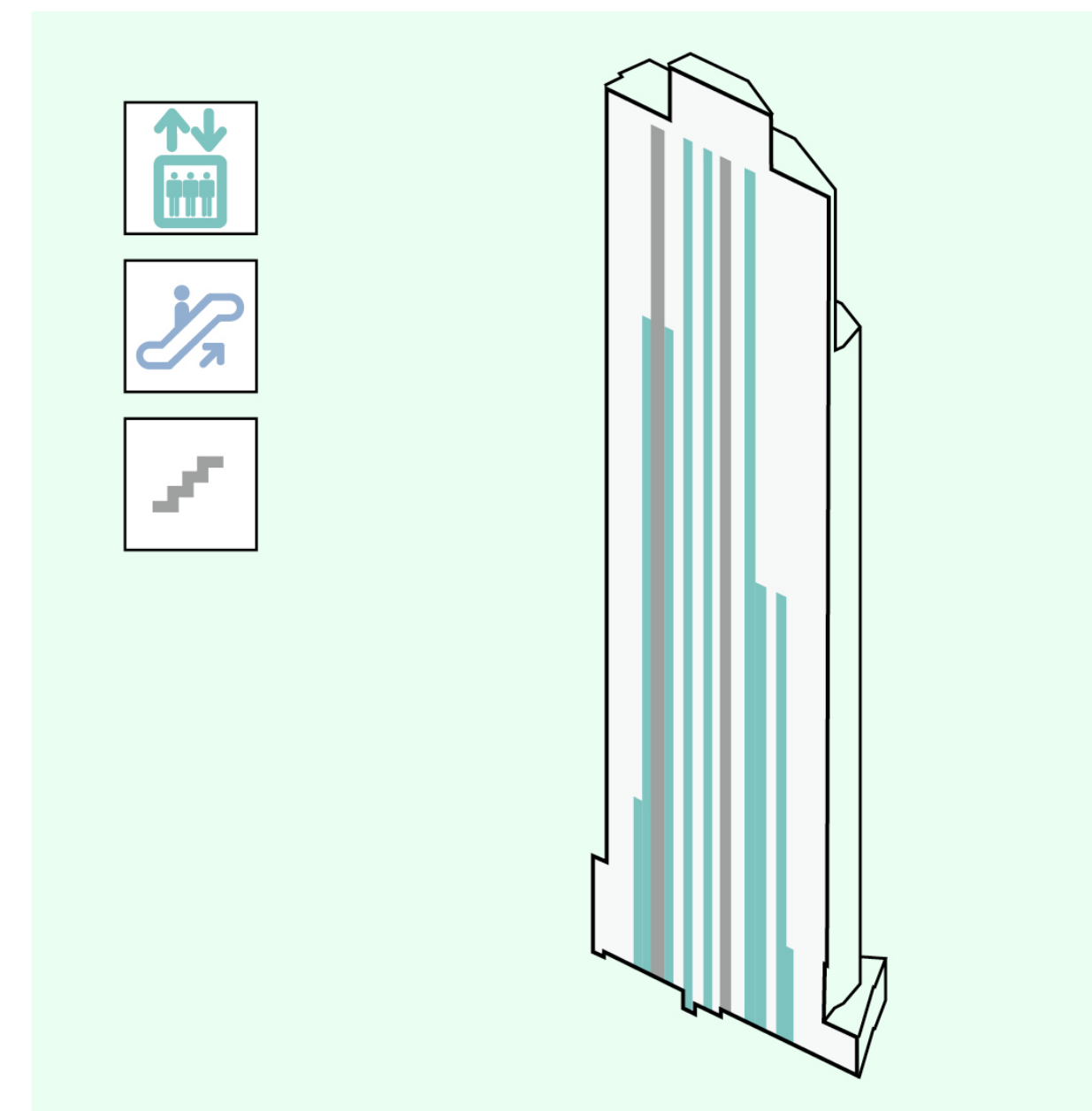

“The first vertical village in London.”

△ 22 Bishopsgate(PLP Architecture)

△ Transportation Analysis

22 Bishopsgate Analysis :Research

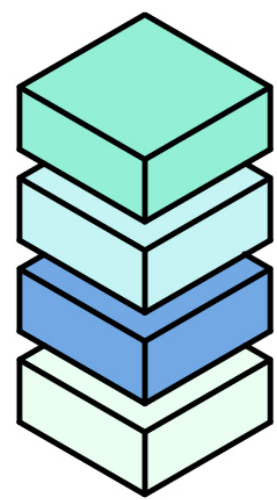

Vertical Village

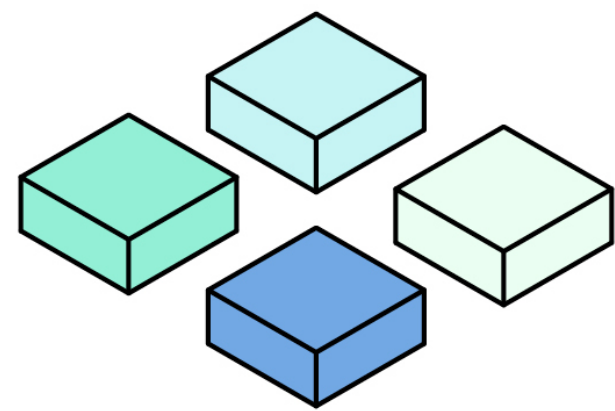
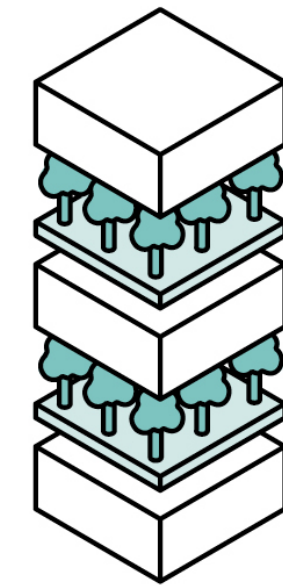
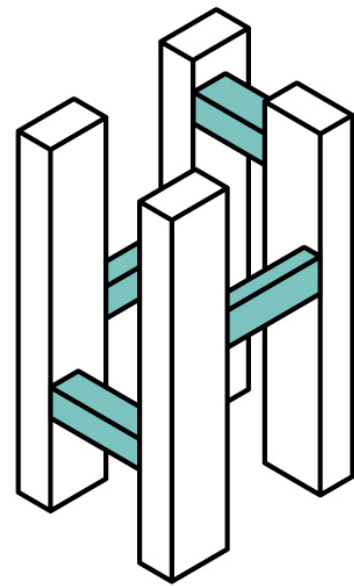
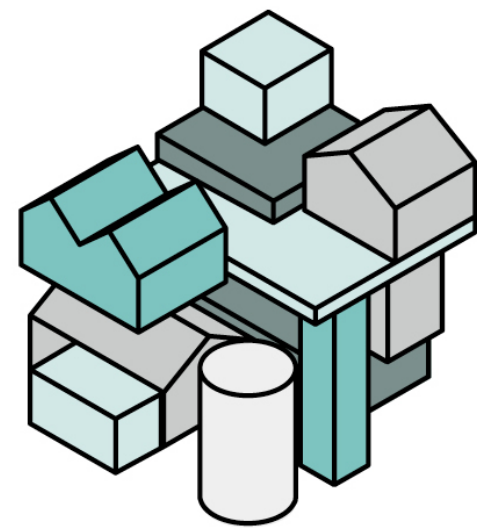

Village

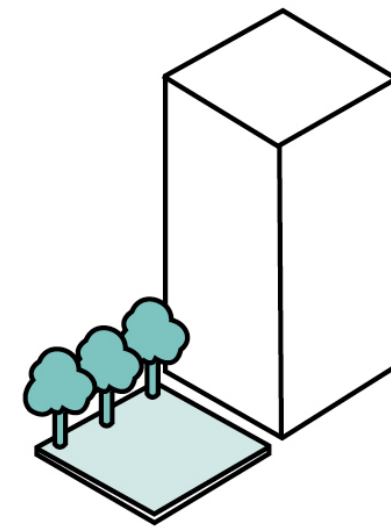
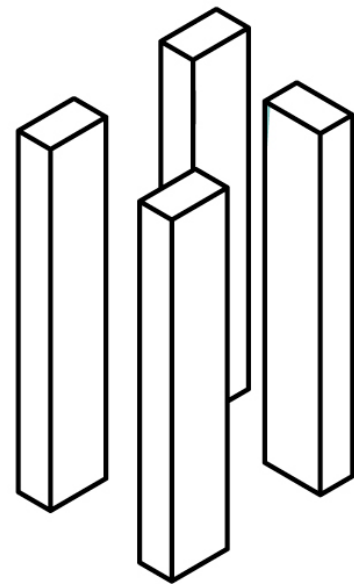
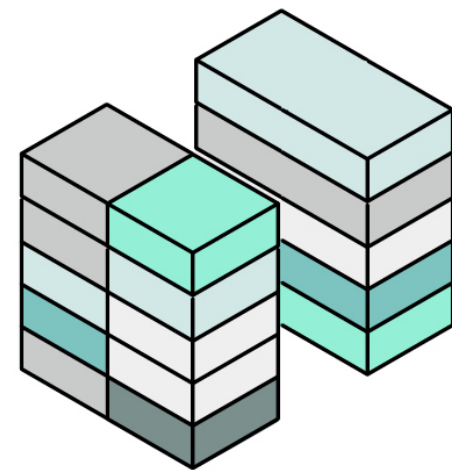

Vertical Village

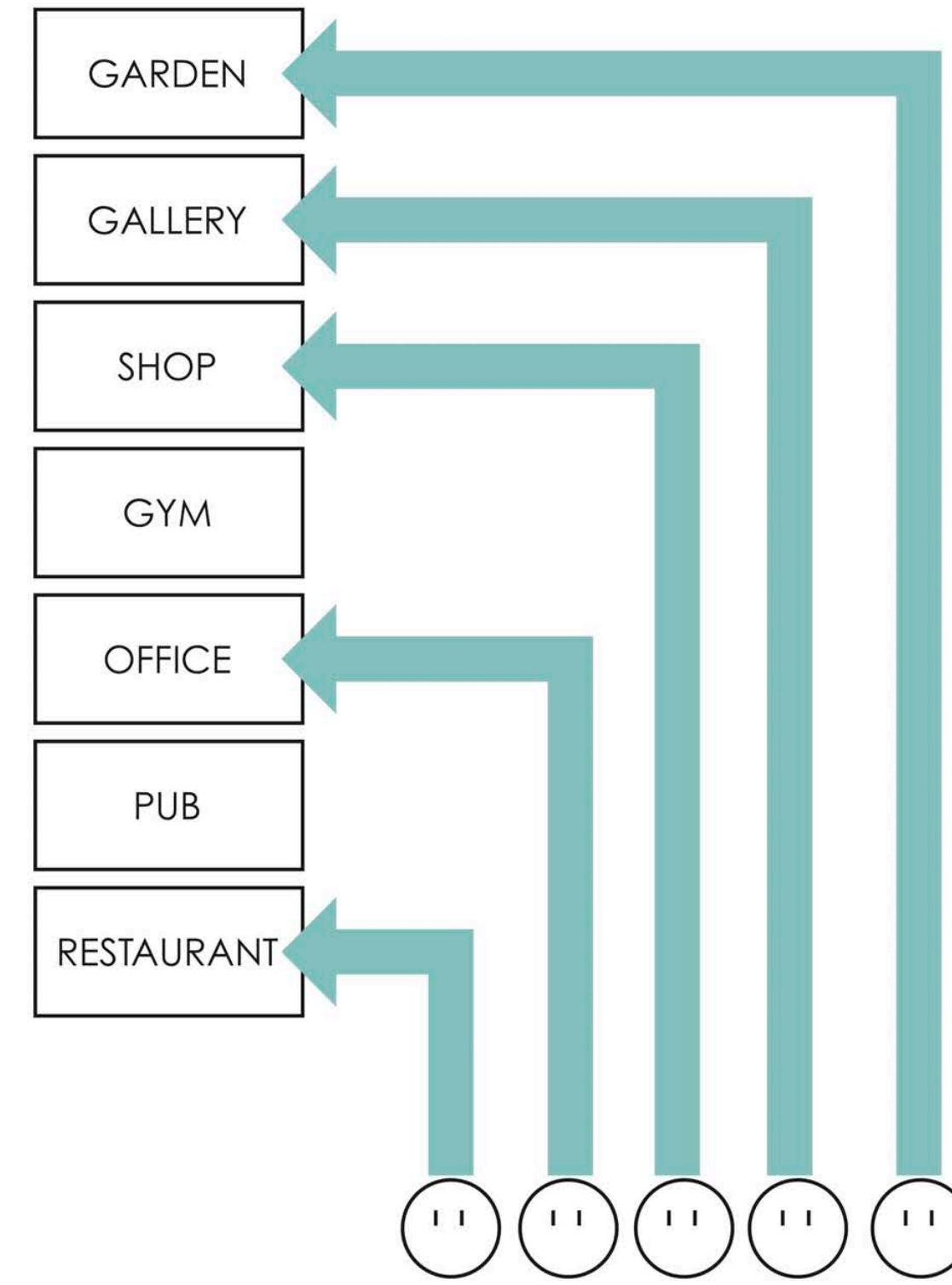
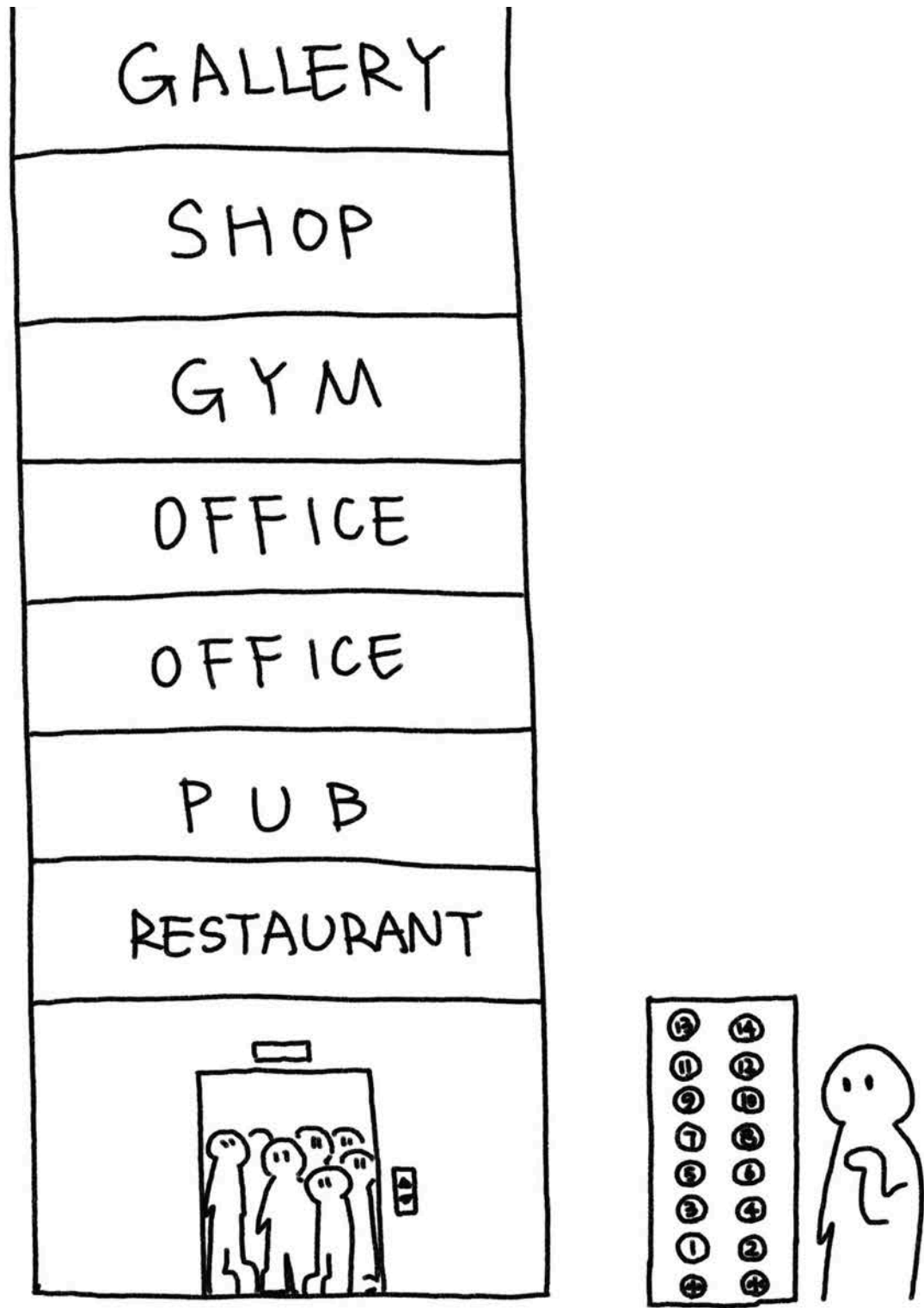

Village

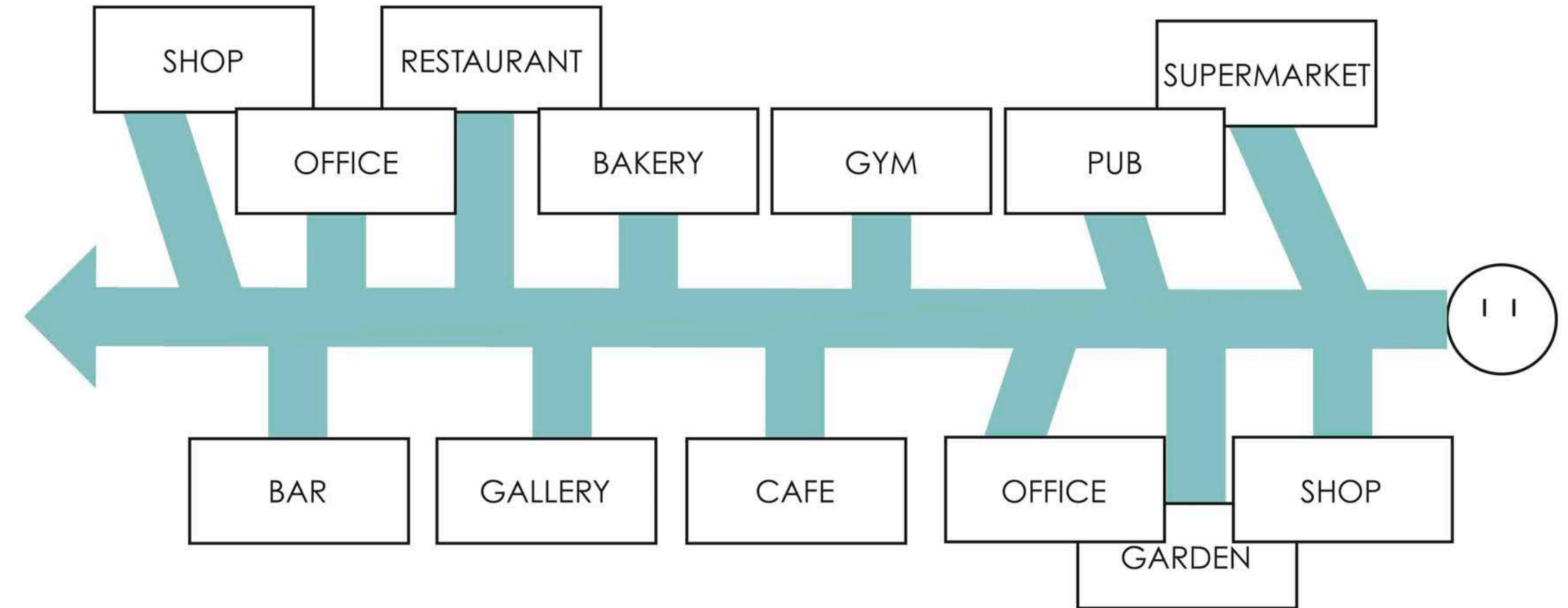

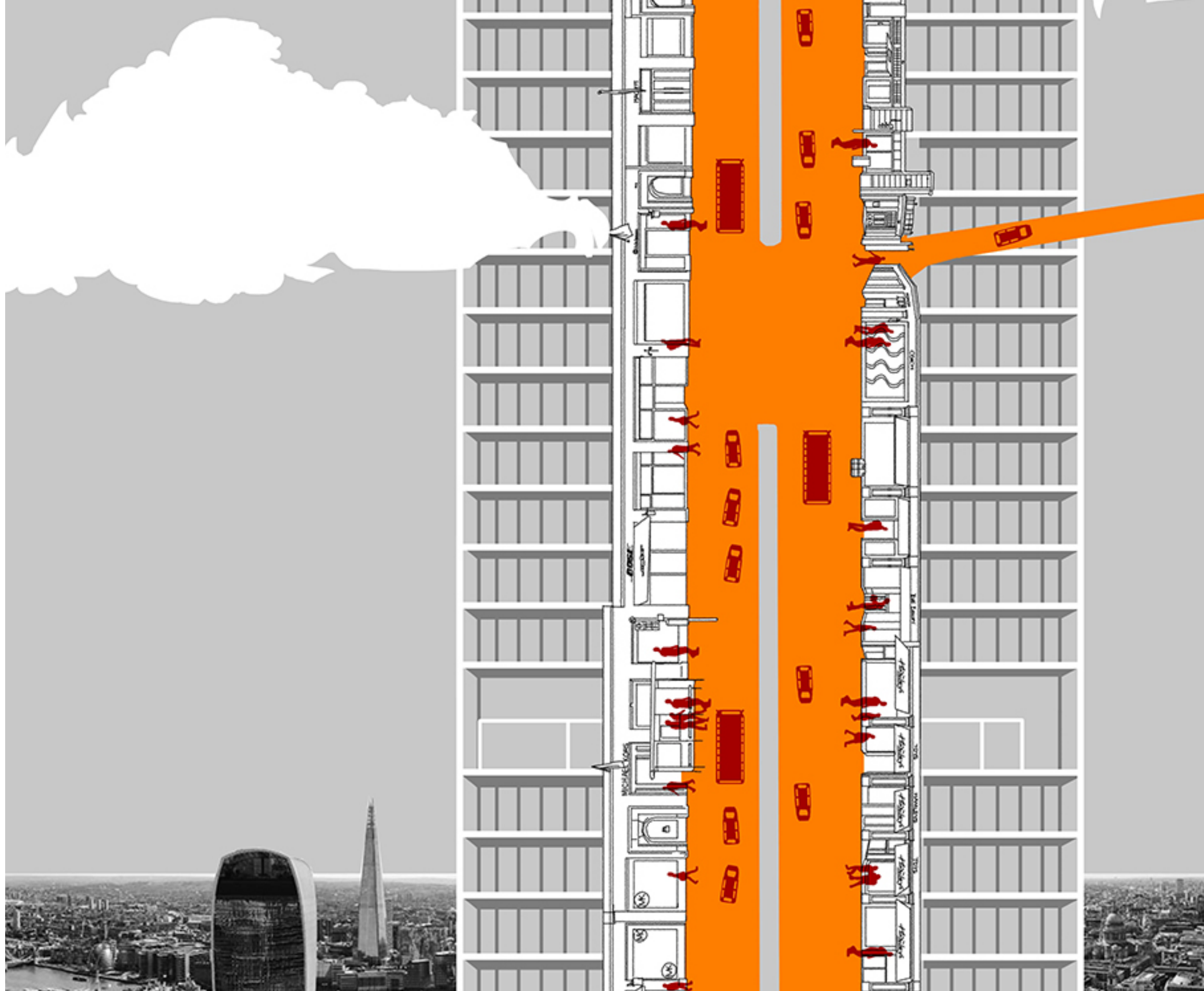
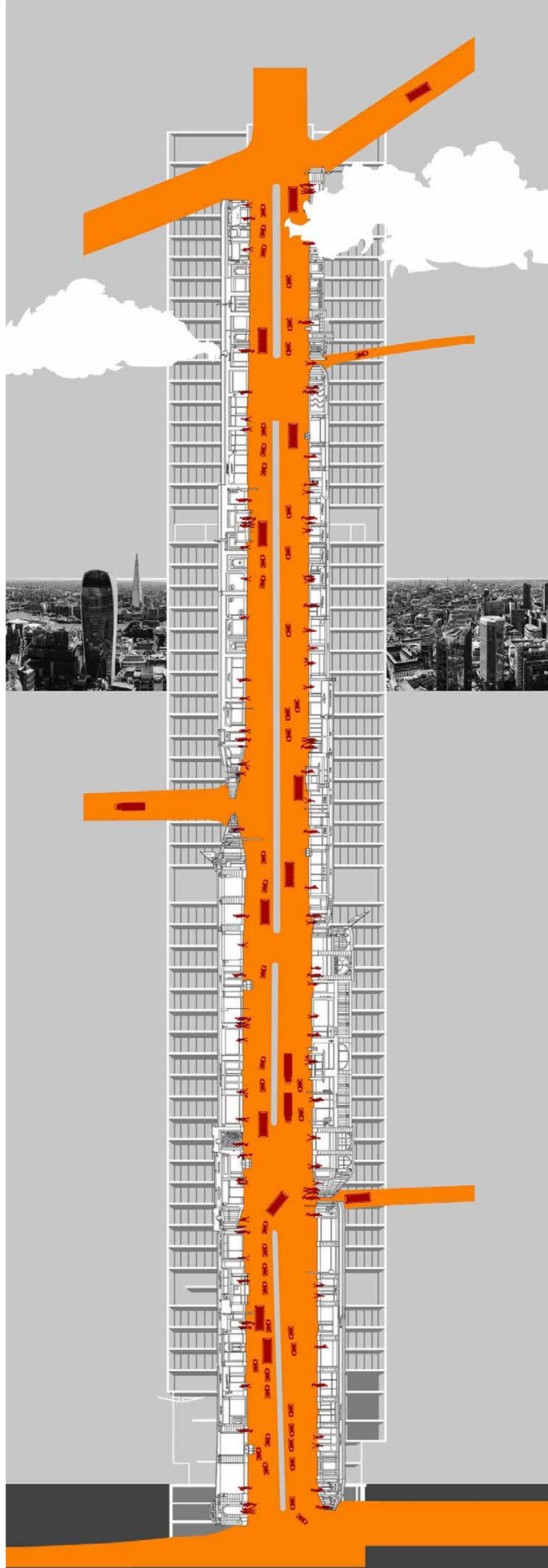

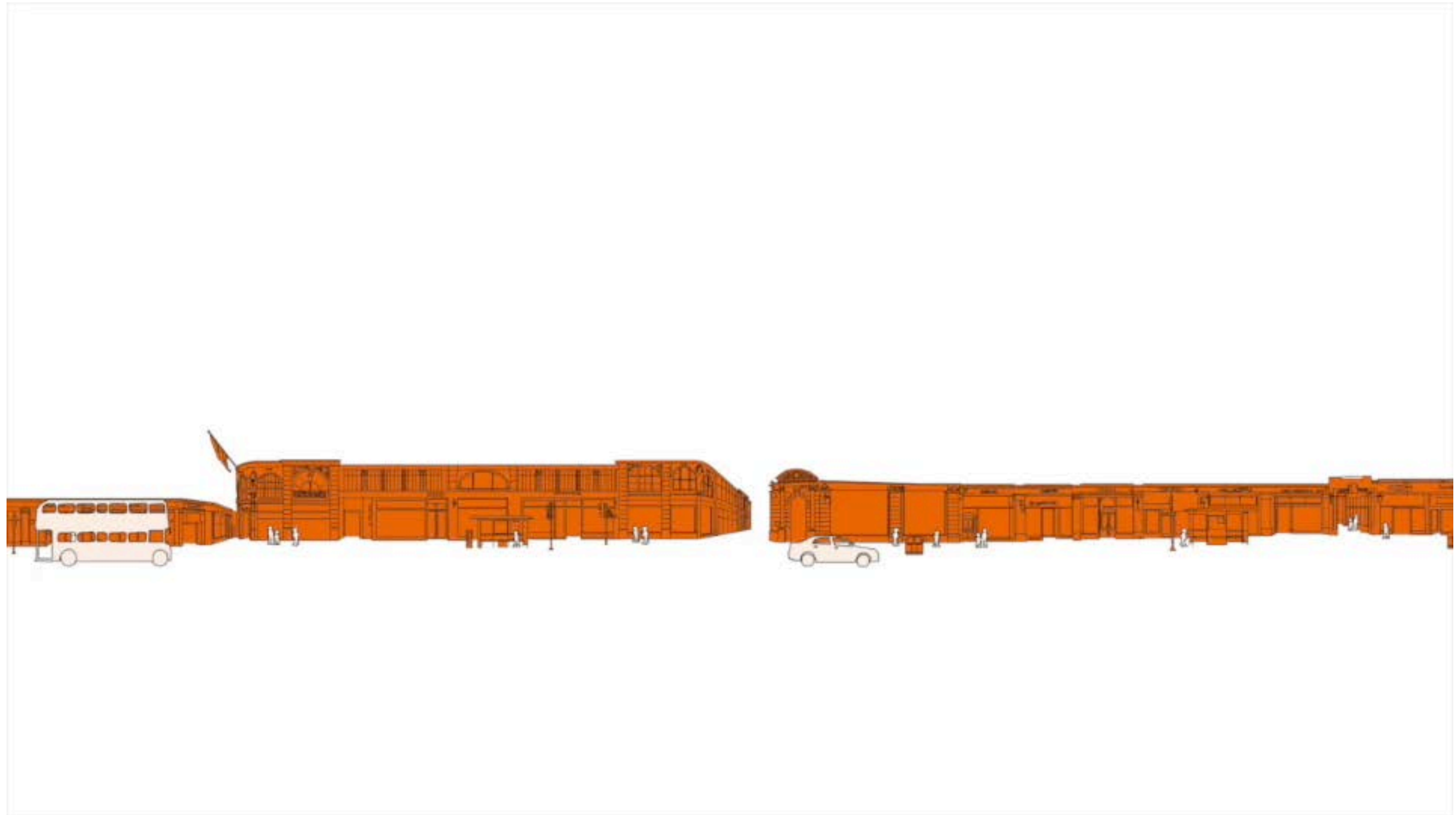

Vertical Street Concept :Development

Tower

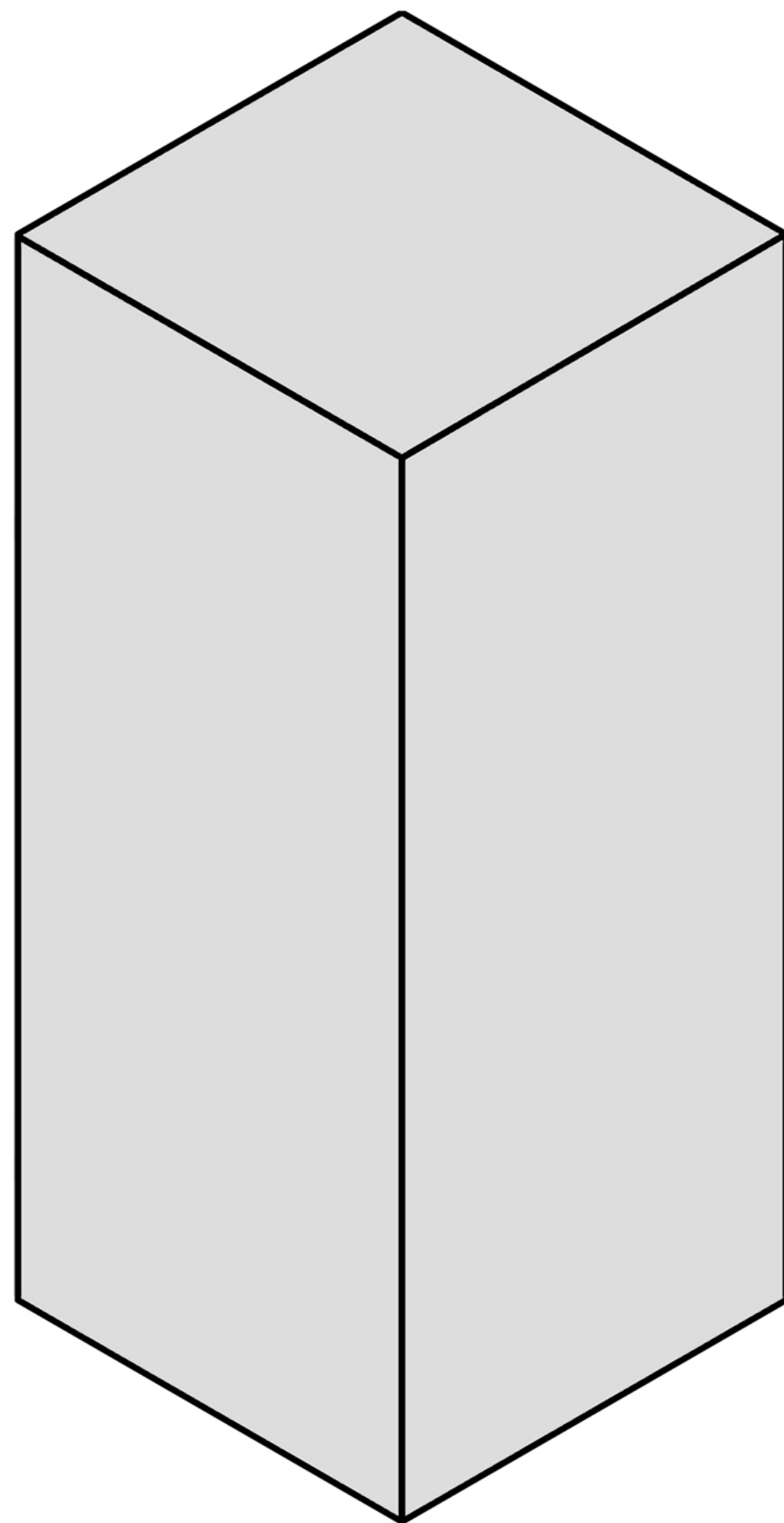

Core

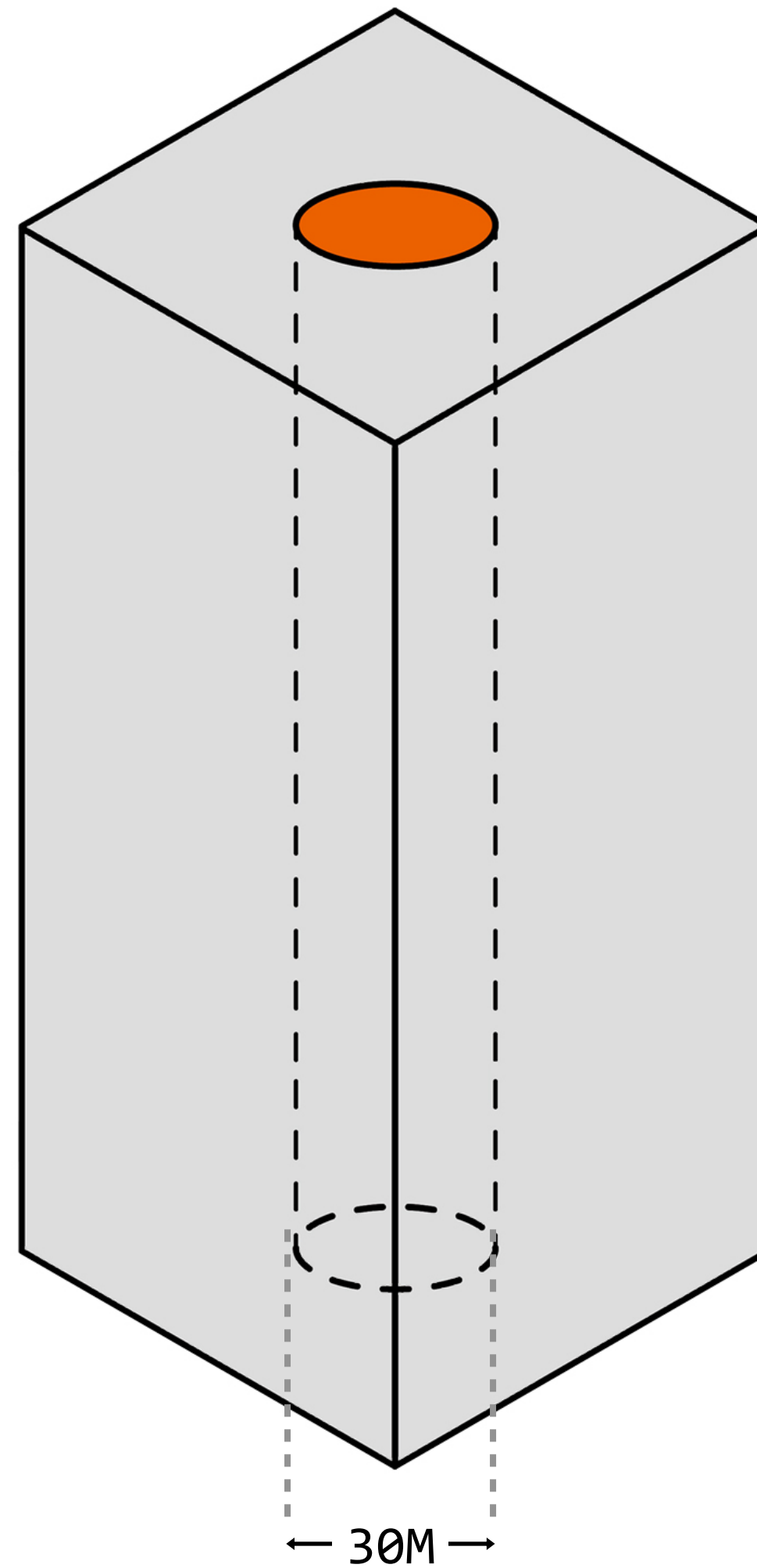

System

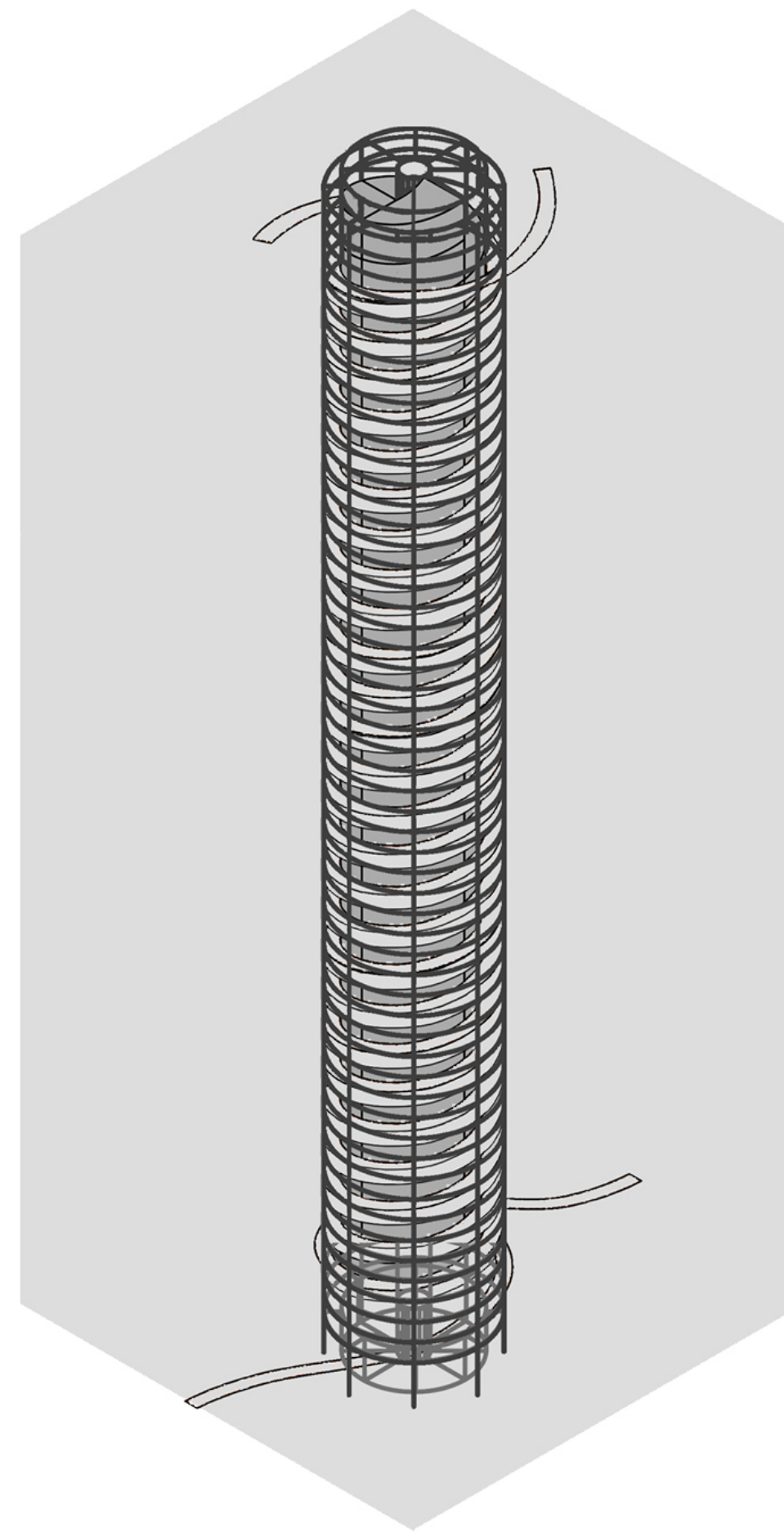

Structure

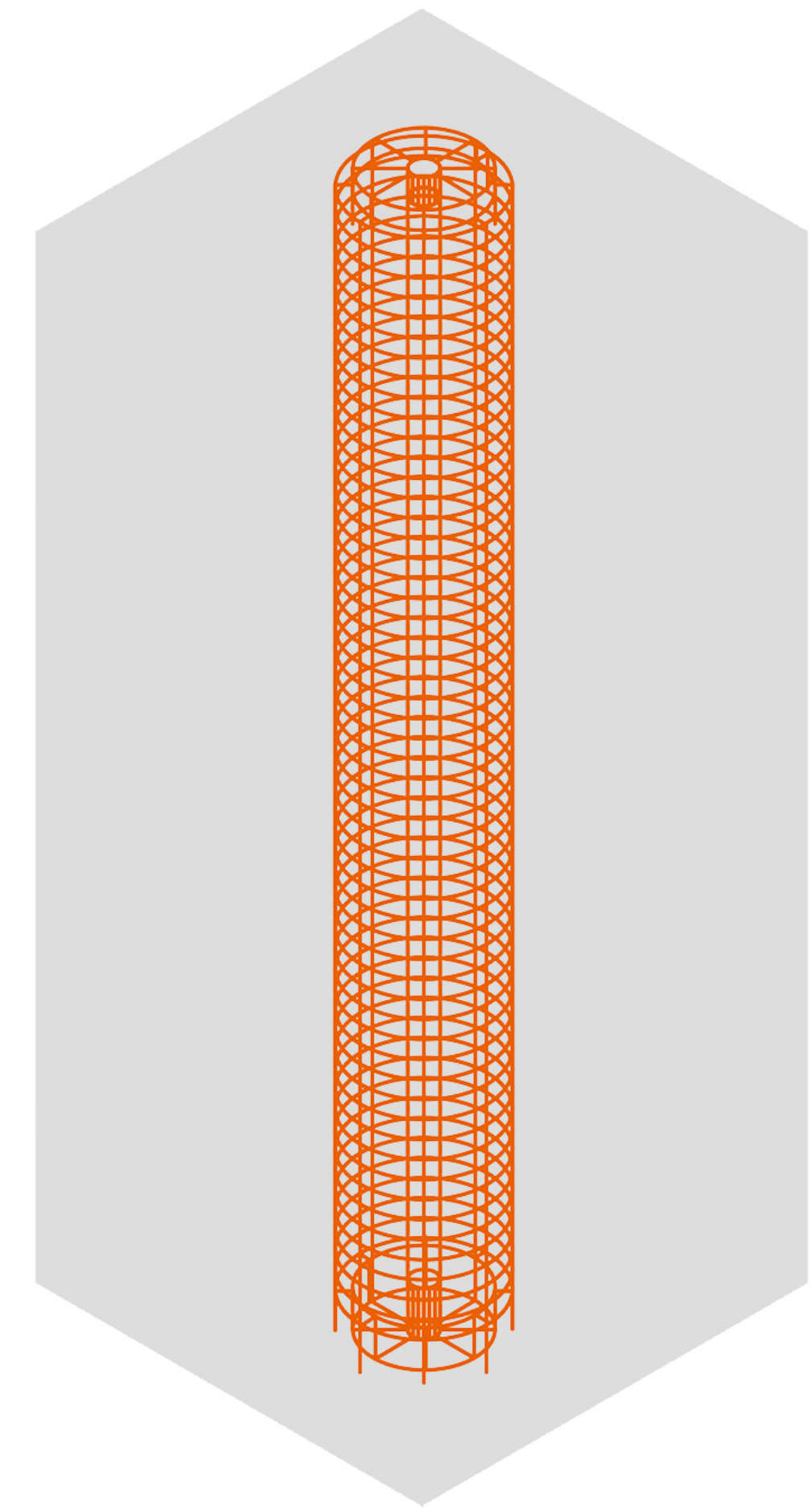

The Structure :System Operation

Amenity Unit

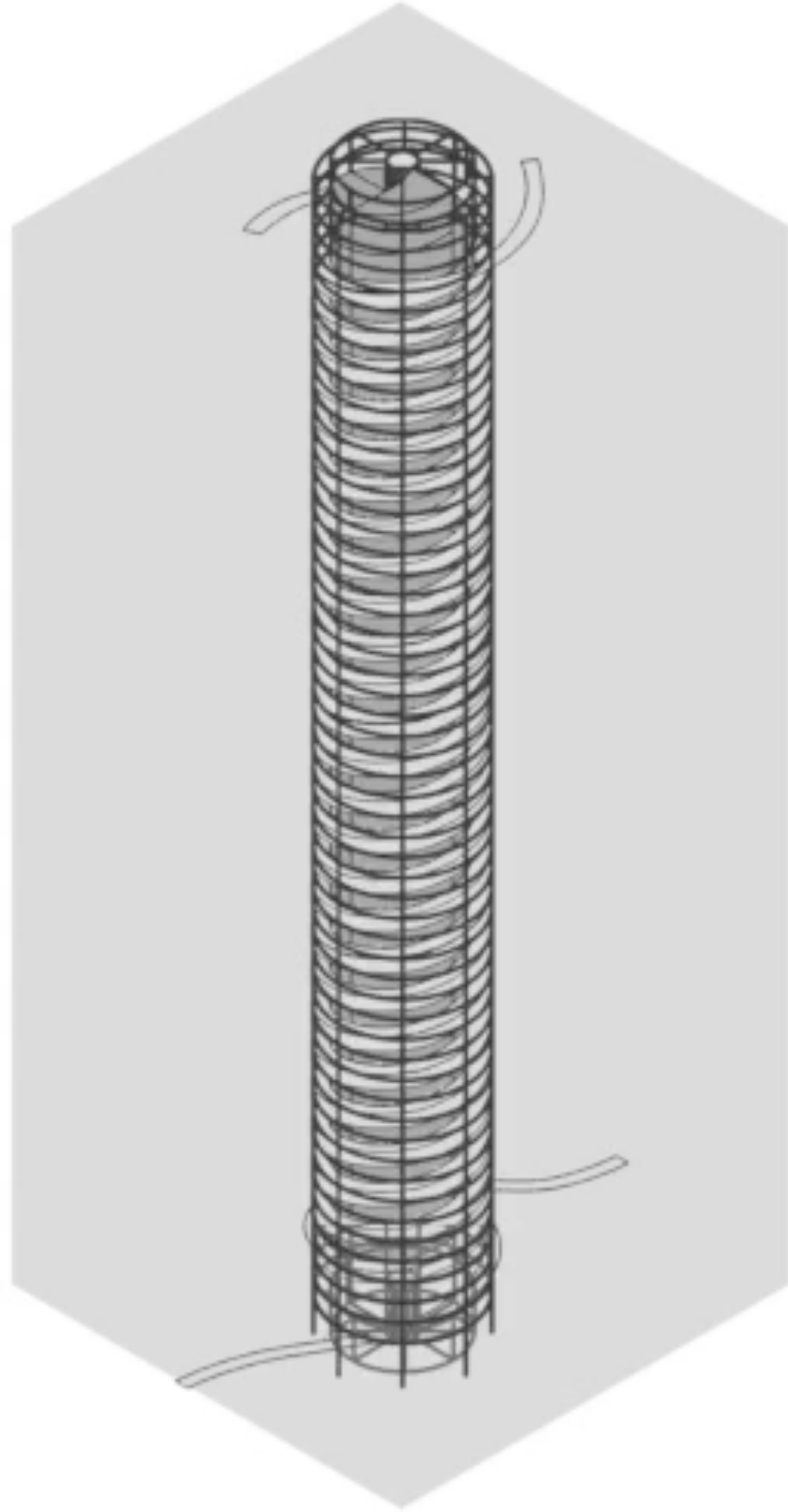

Spiral Pavement

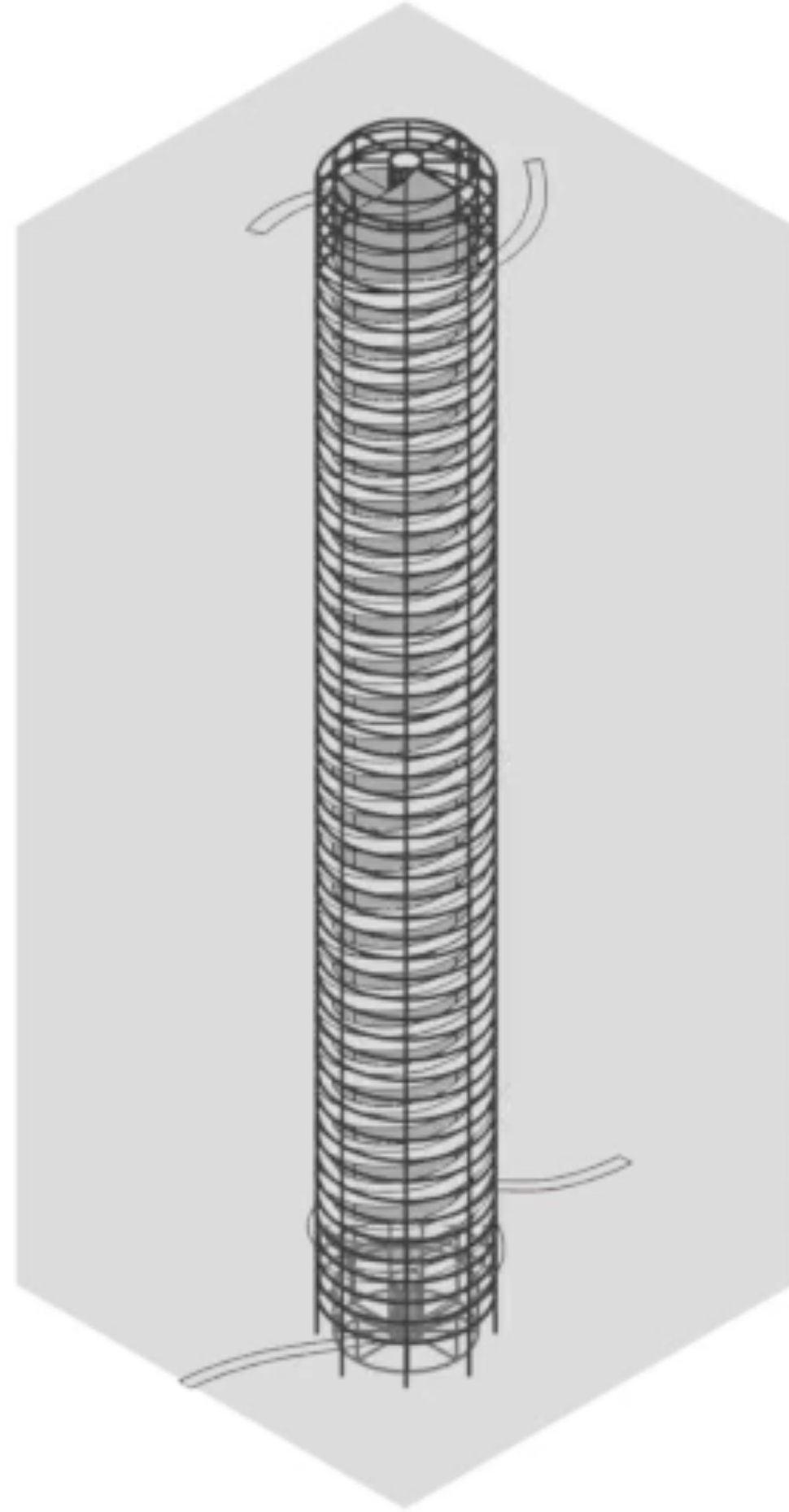

H-Train

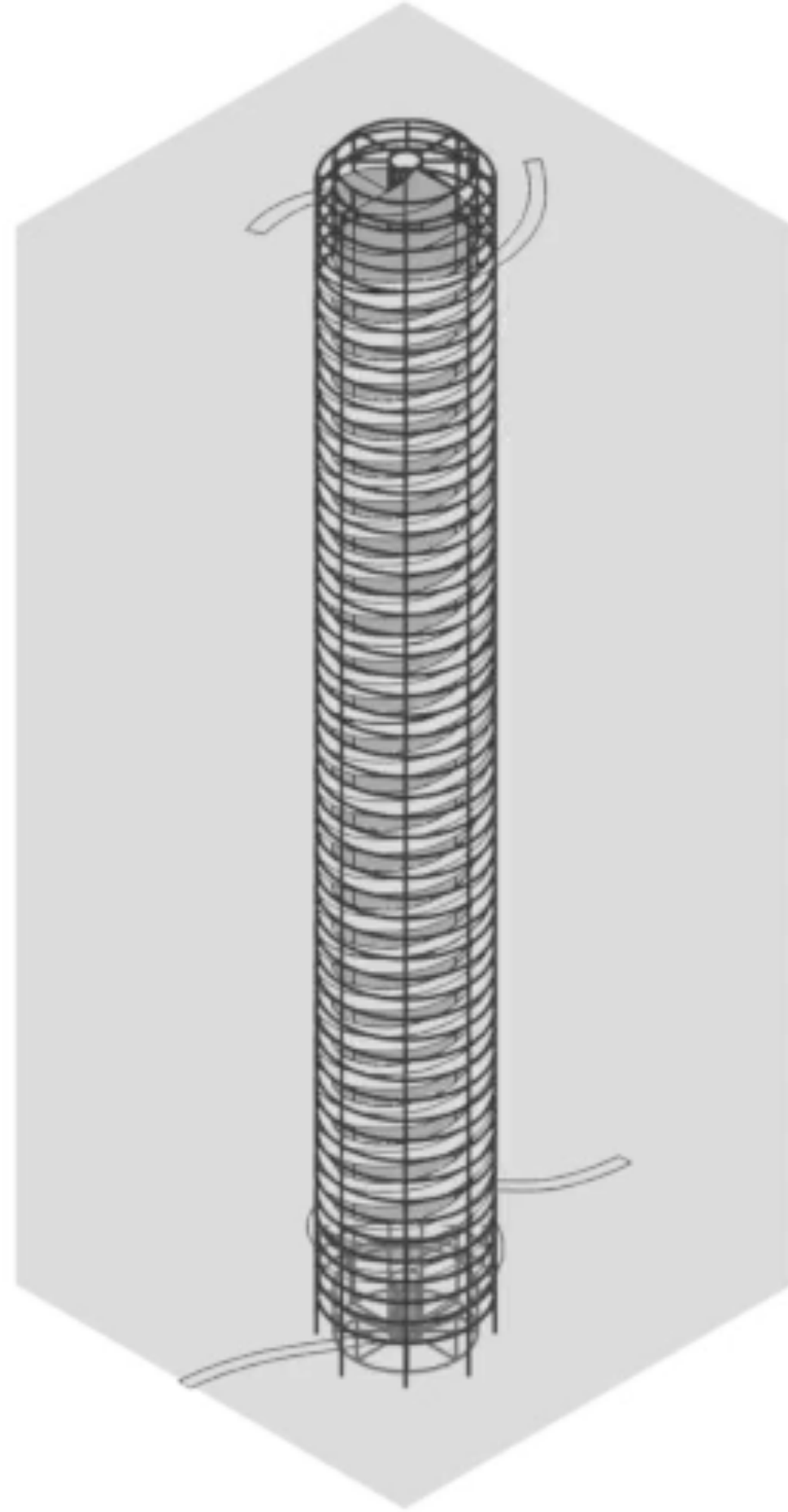

Setback

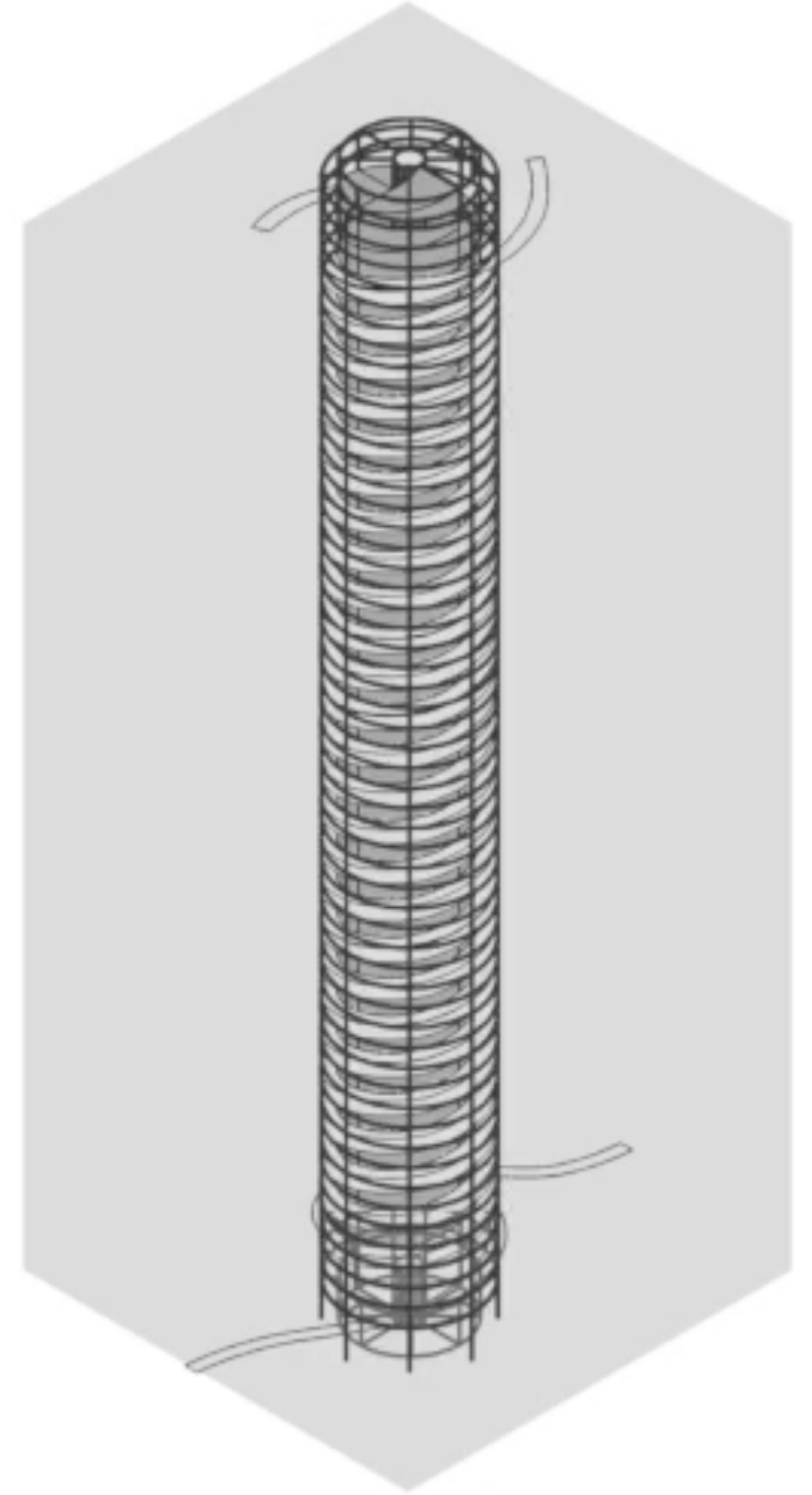

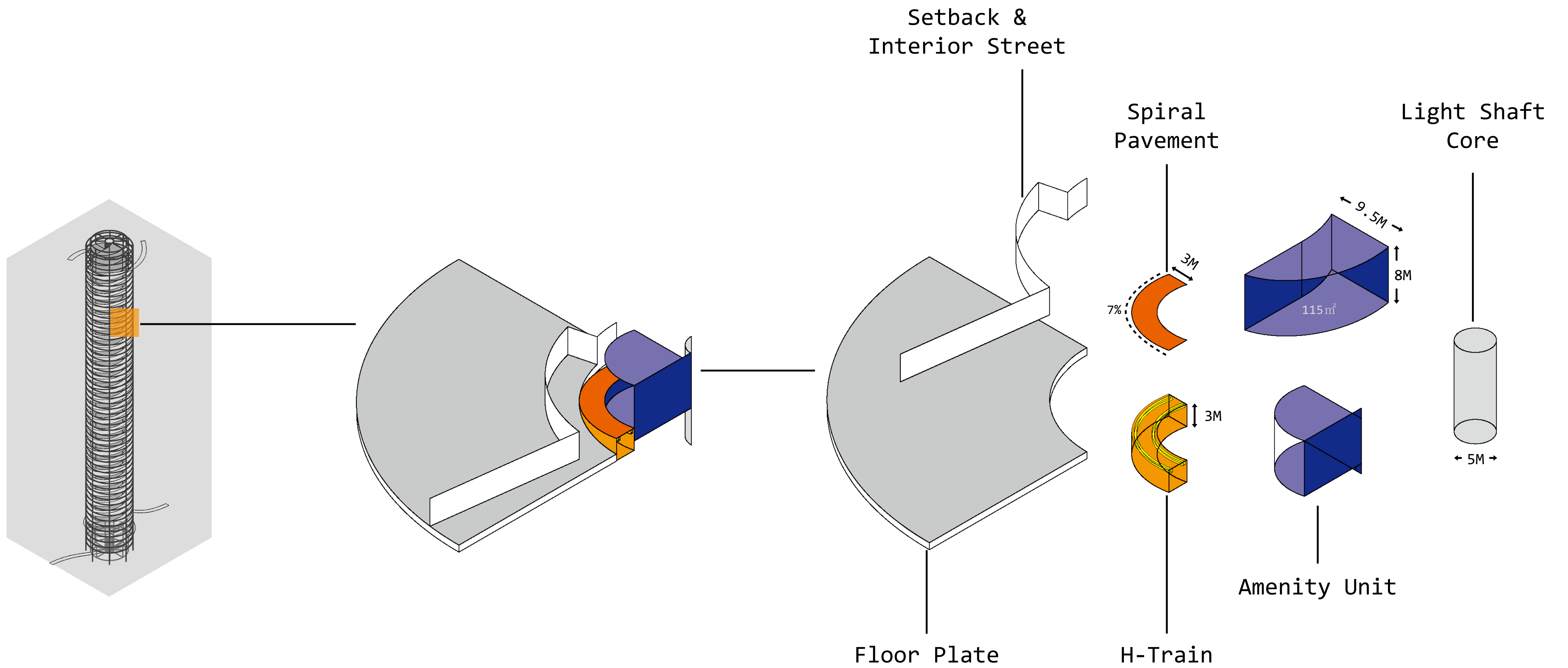

△ The System

△ Standard Group

△ Parts

The Elements

Amenity Unit

Cycle: 24h

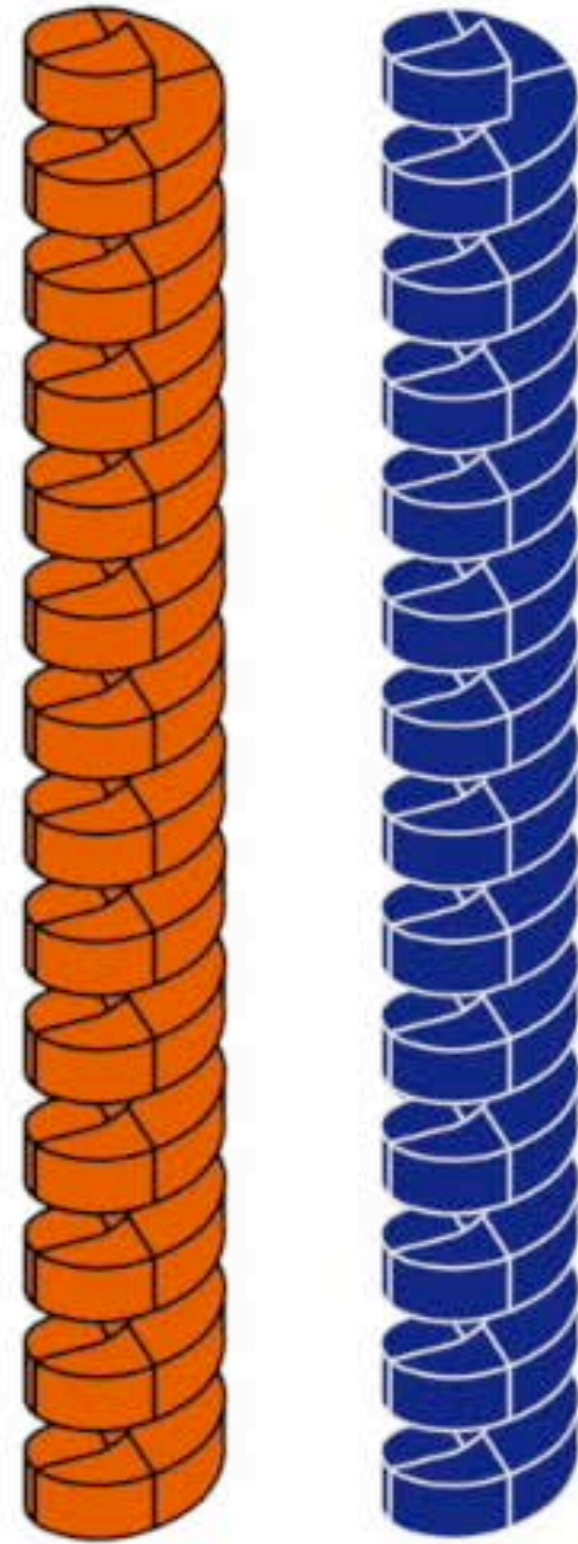

△ Upwards

△ downwards

Spiral Pavement

length: 1.5km

walk: 20min

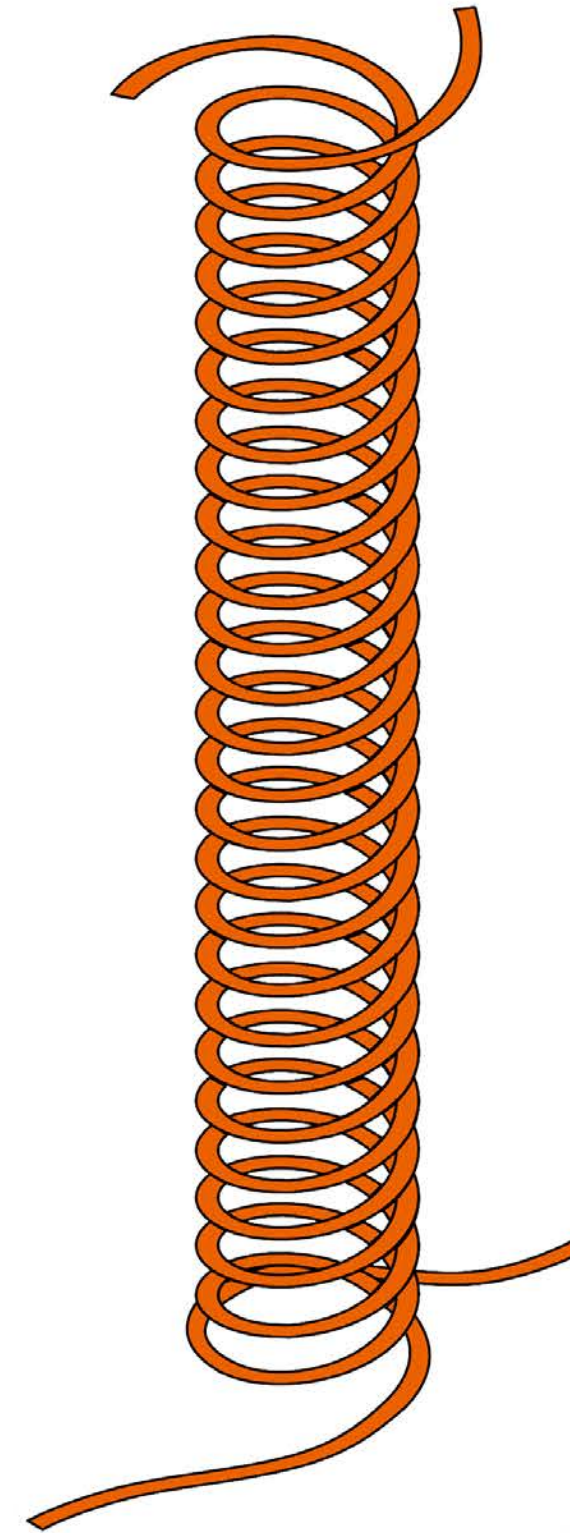

H-Train

Cycle: 8min

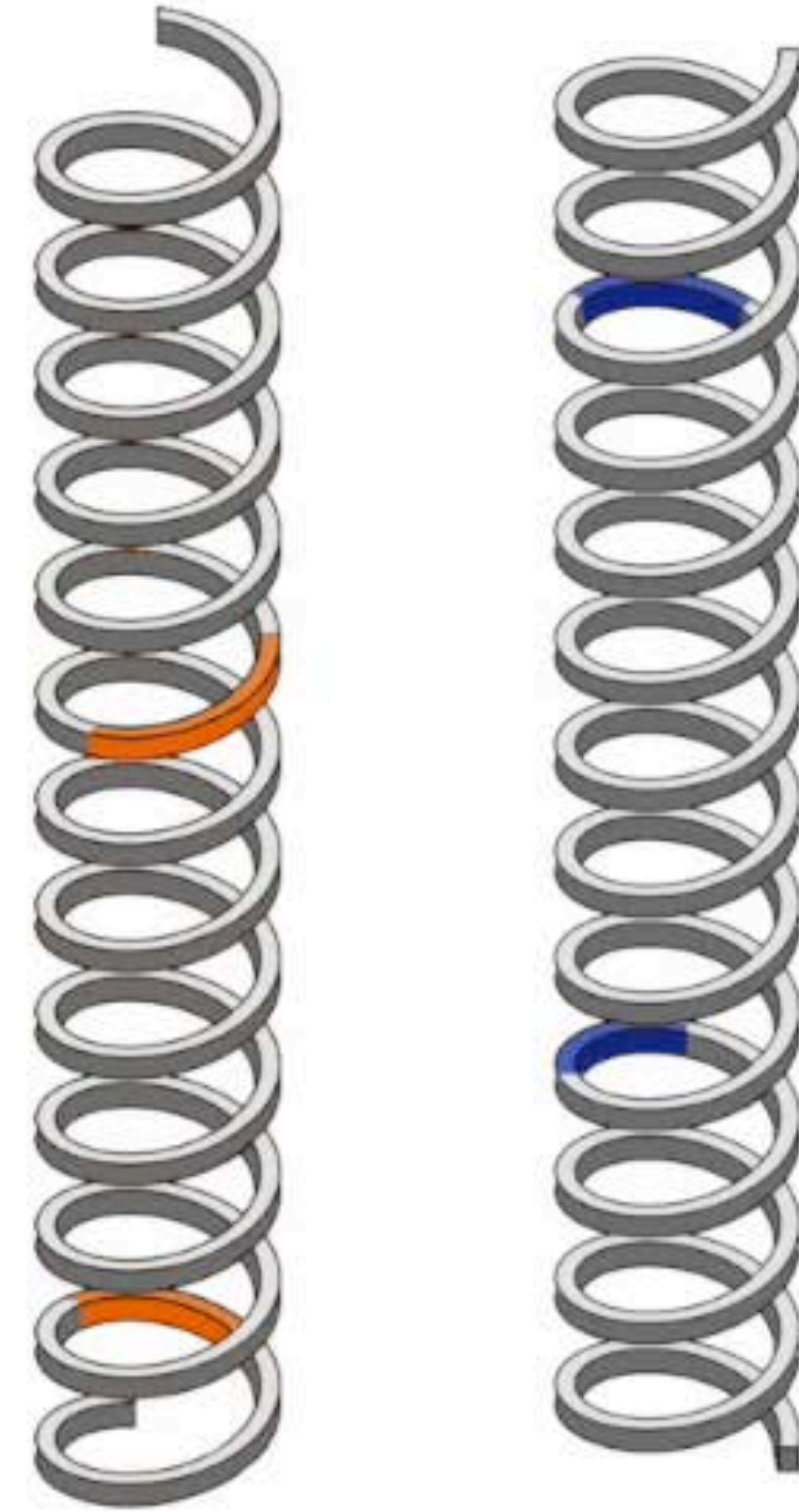

△ Upwards

△ downwards

The Moving Elements :System Operation

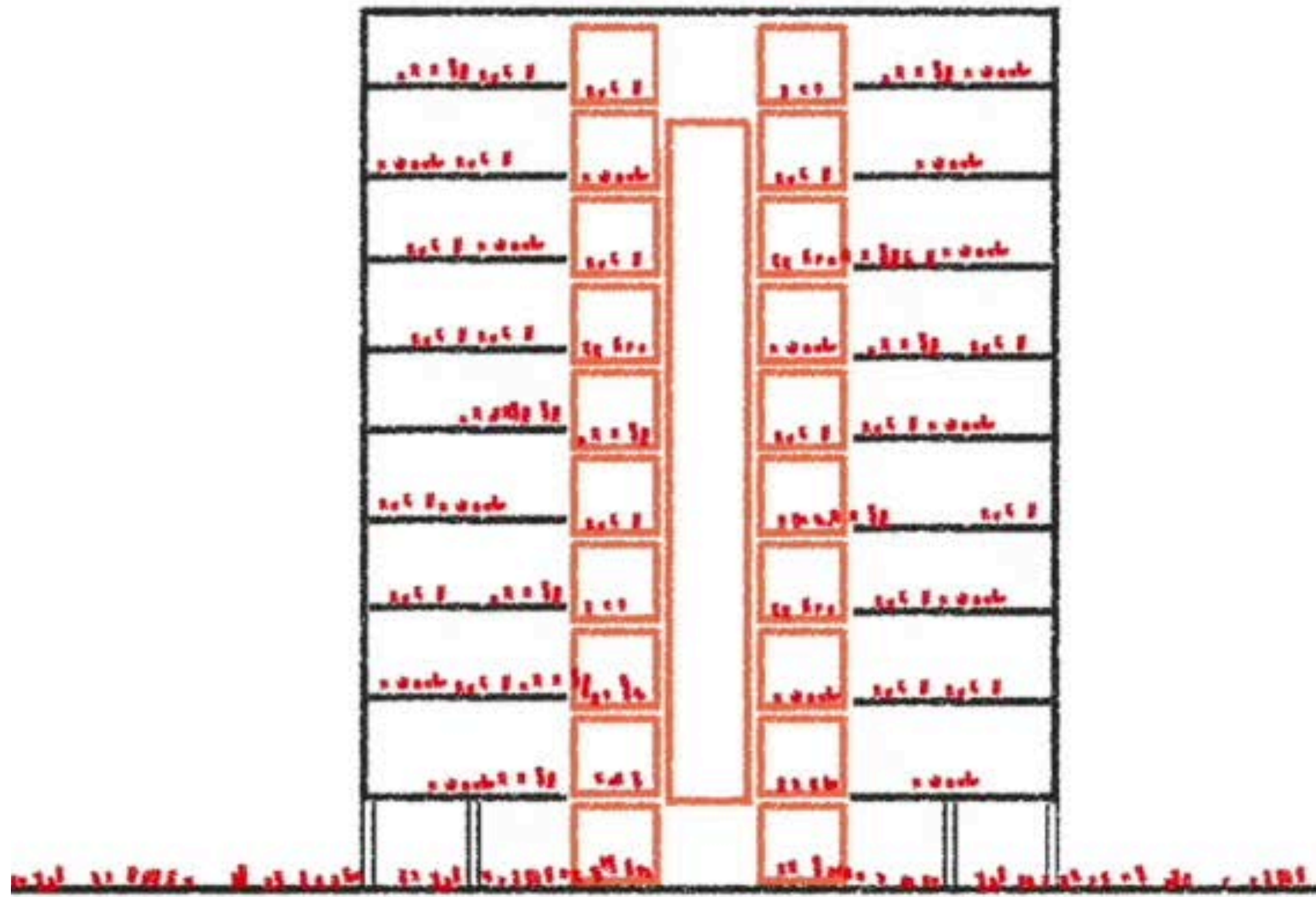

△ Building Section

The Moving Elements :System Operation

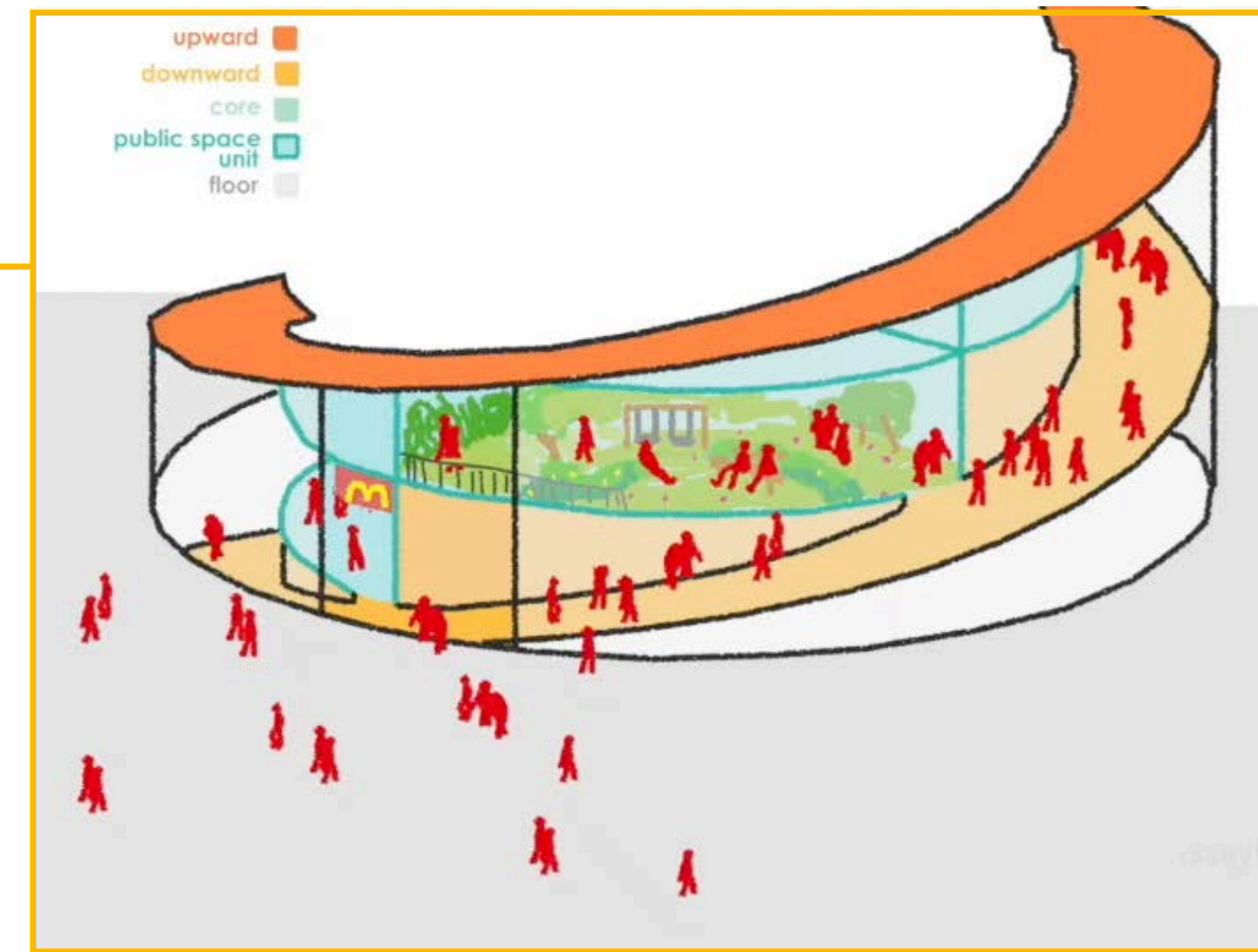
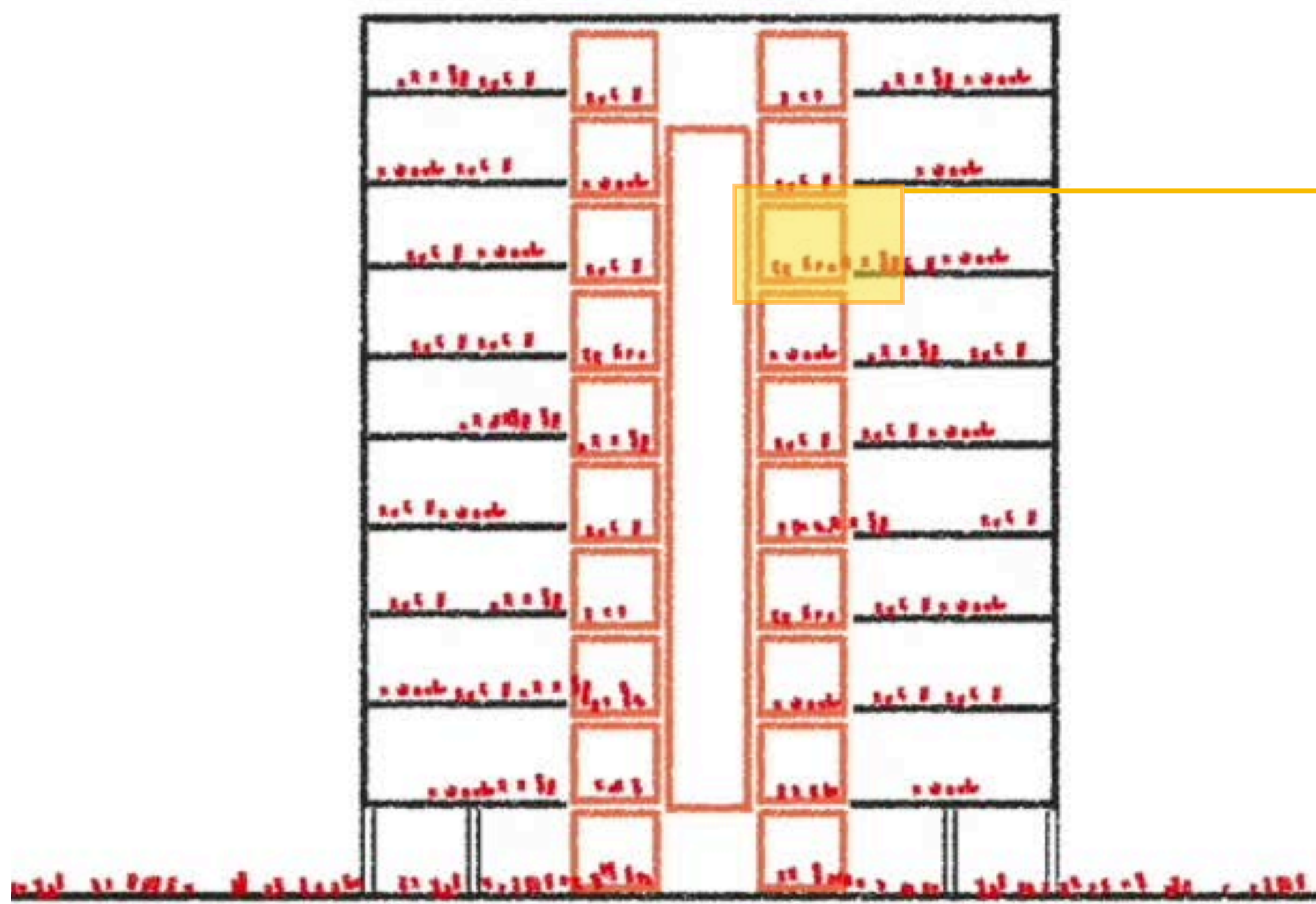

△ Building Section

△ User Scenario

The Moving Elements :System Operation

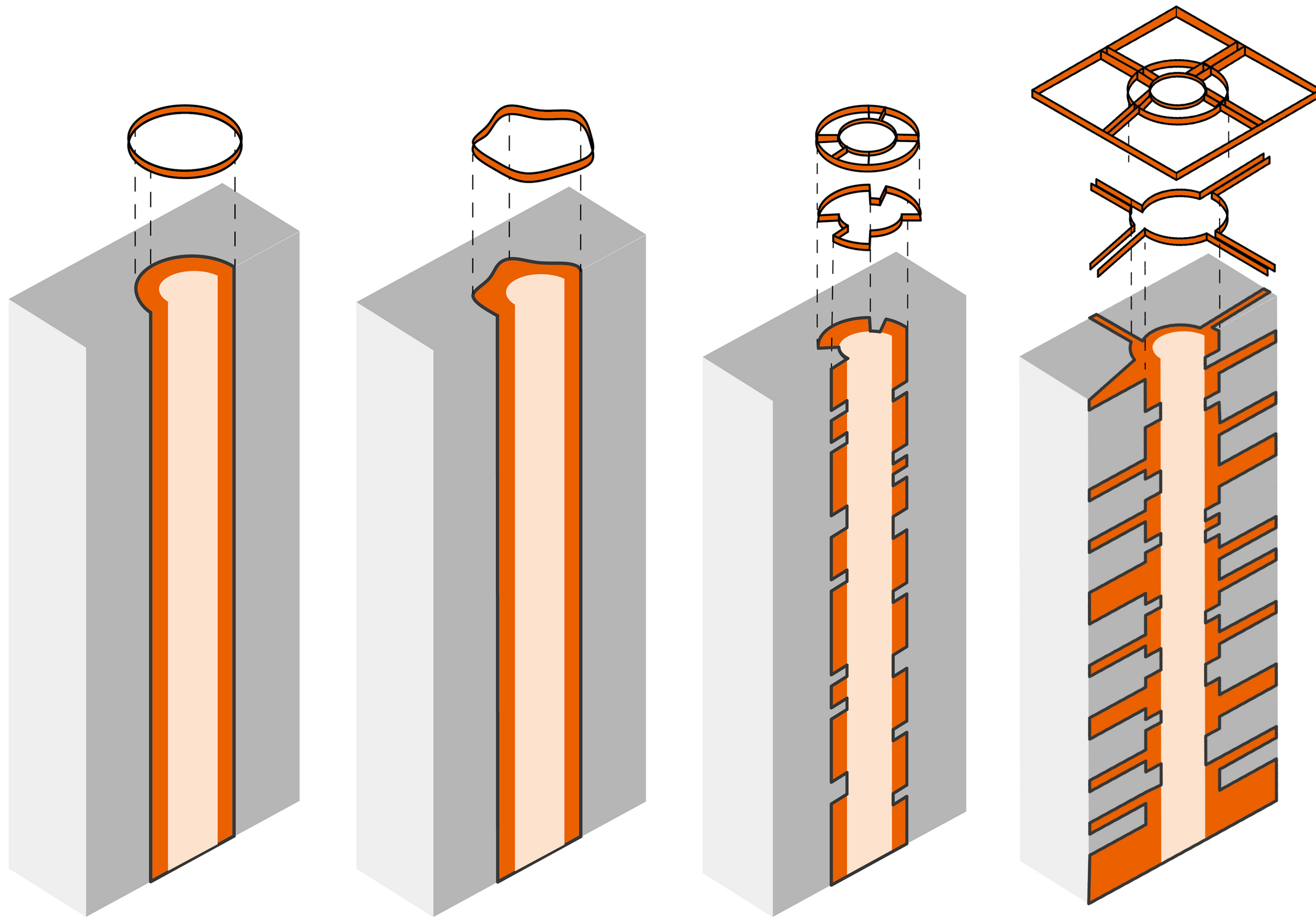

△ Building Section: Strategy Optimisation

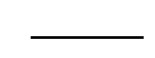

The Interior Street Strategy :System Operation

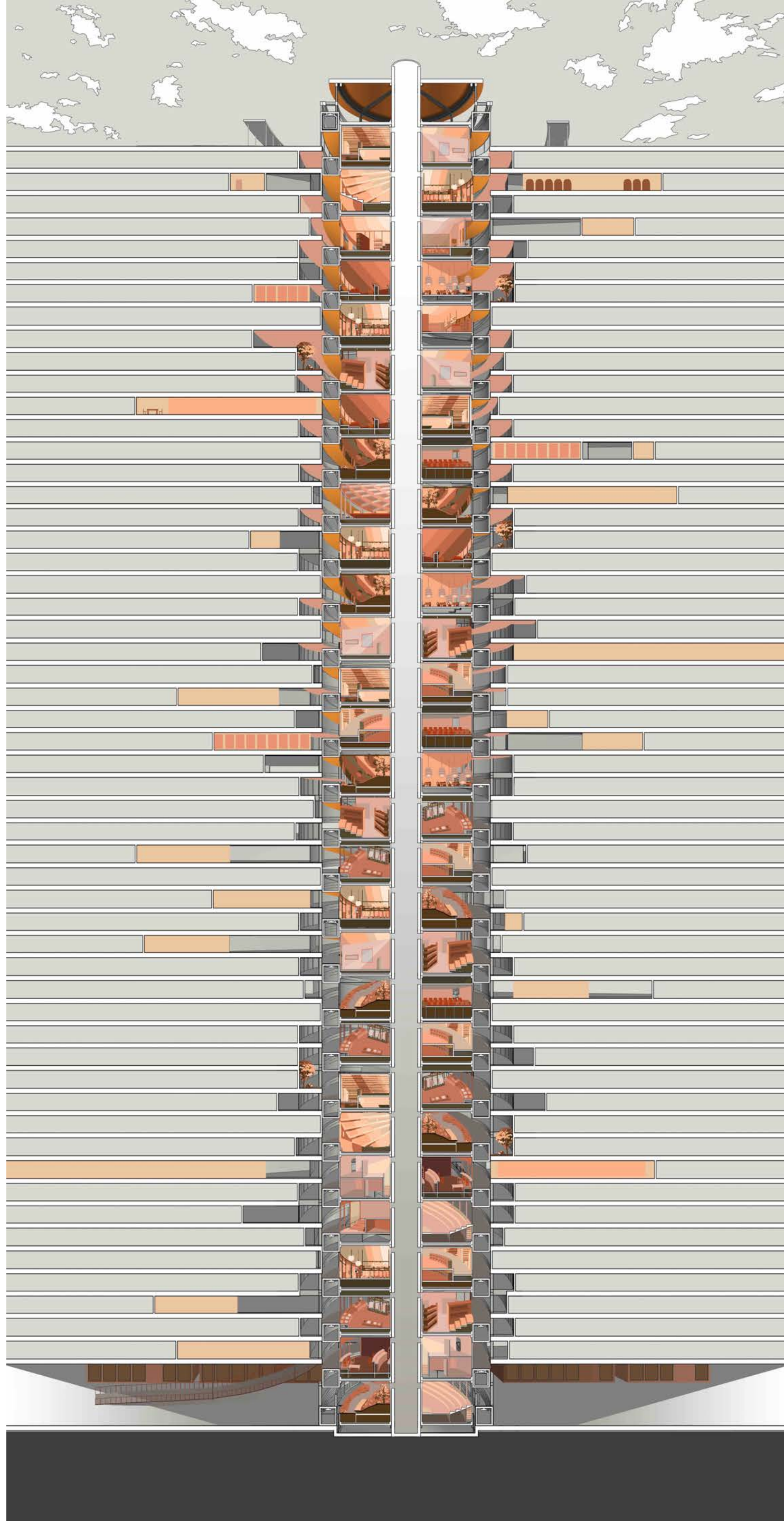

The Section

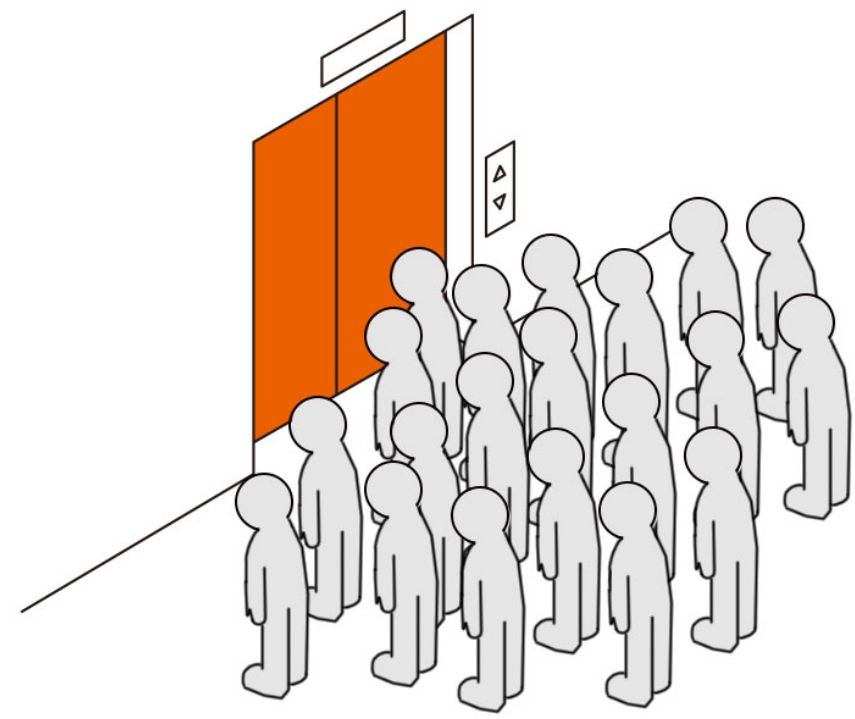

Most Office Building

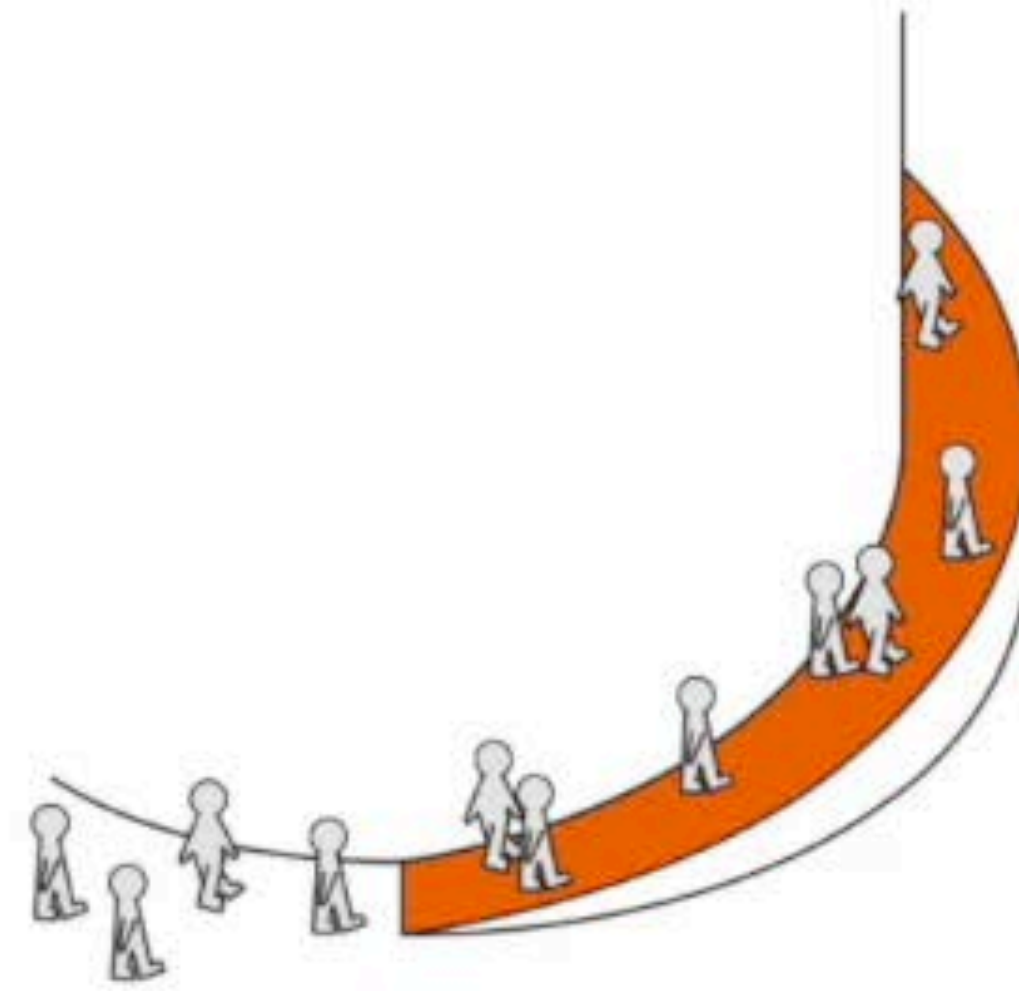

Vertical Street

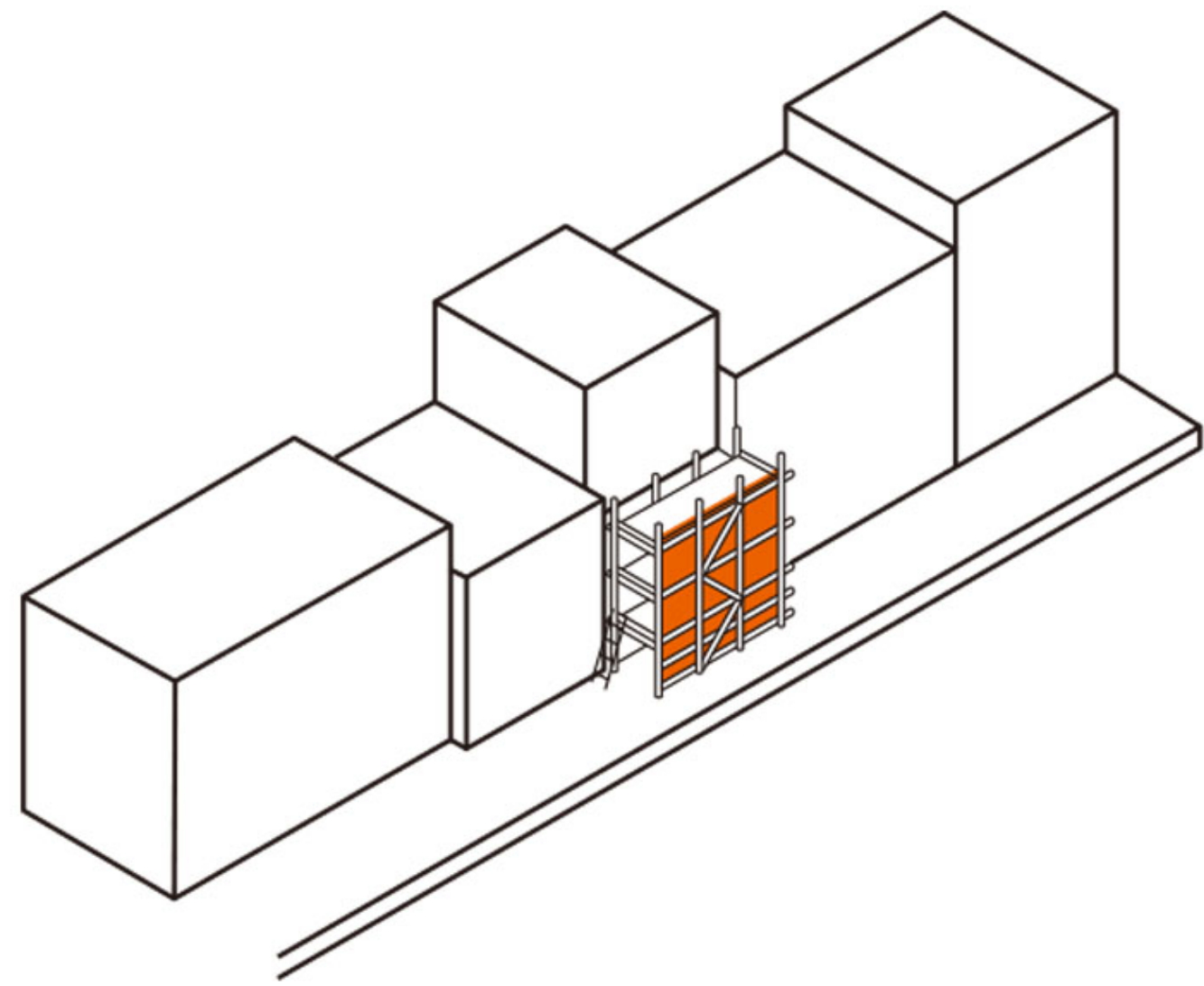

Horizontal Street

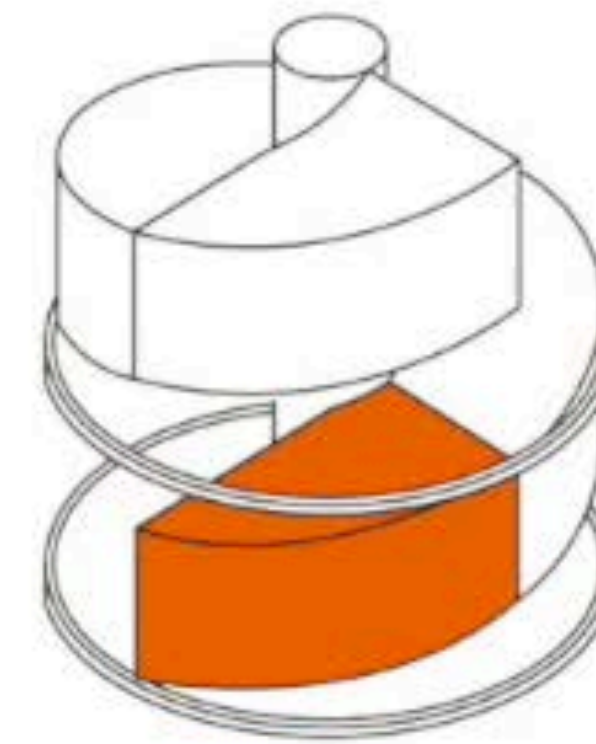

Vertical Street

Renovation :Analysis :Development

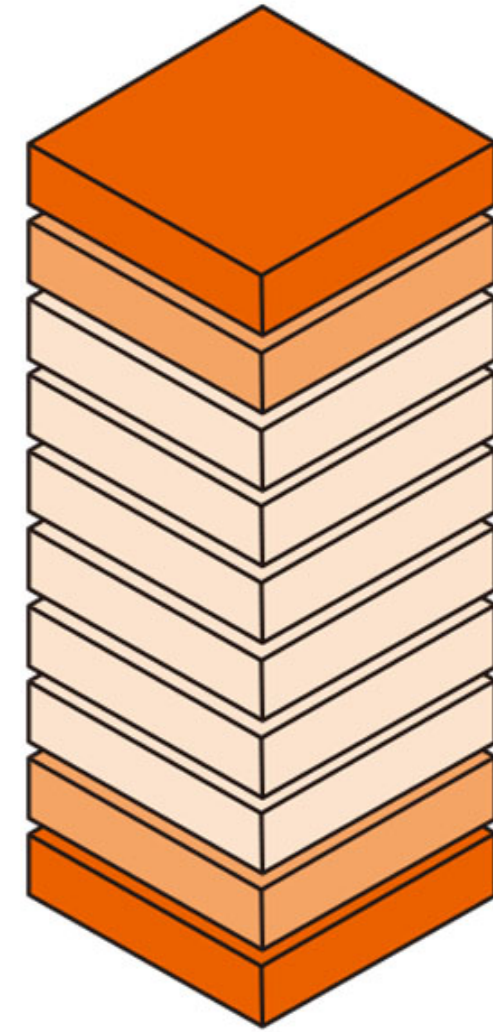

Commercial Building

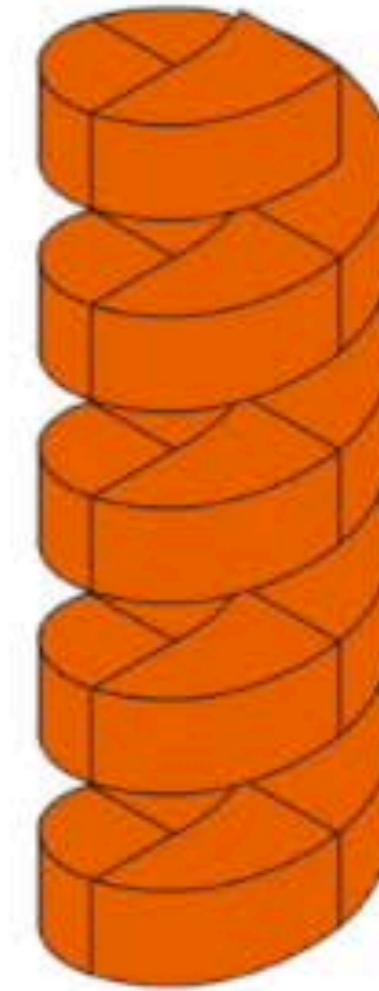

Vertical Street

Commercial Valuation :Analysis :Development

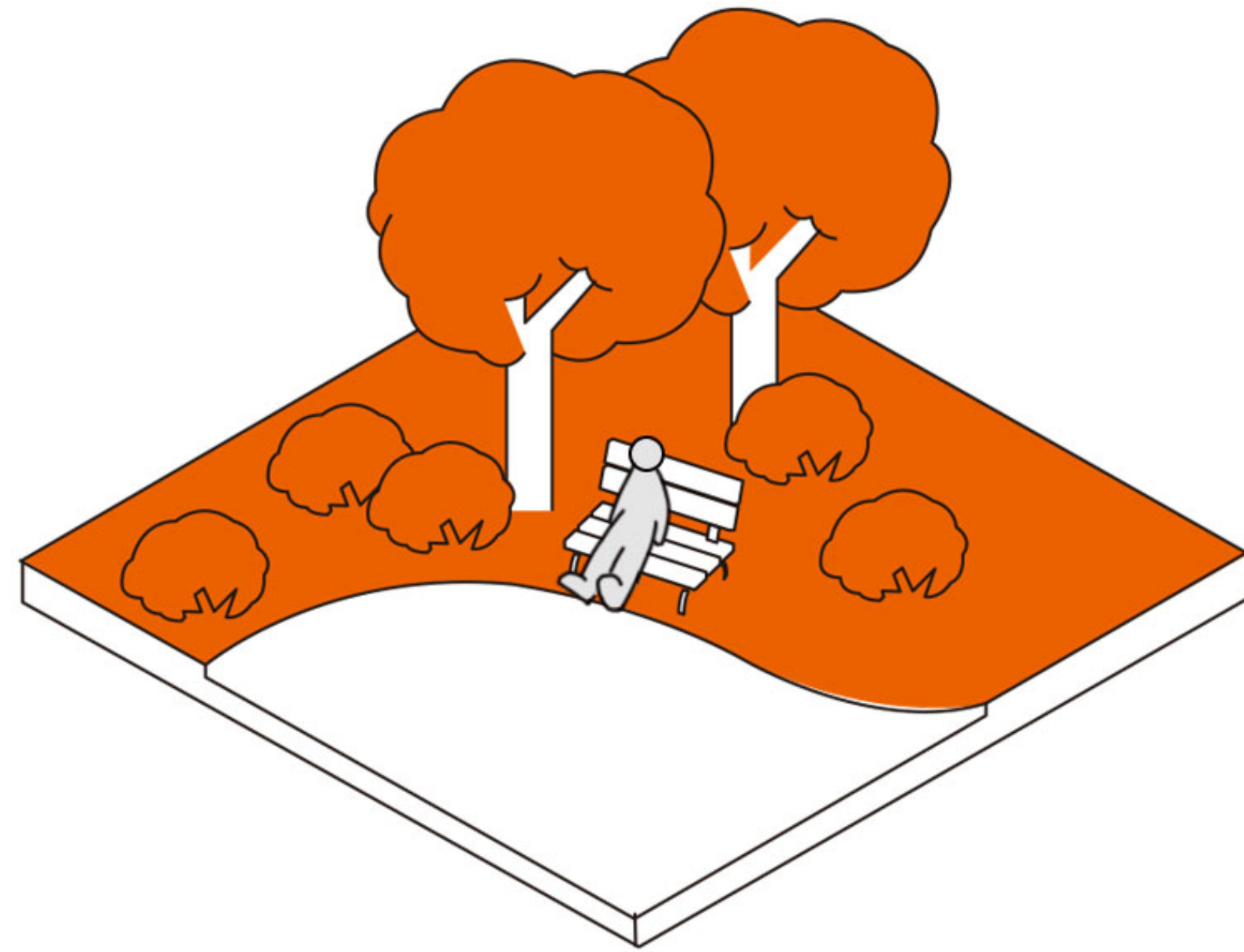

Ground-level Garden

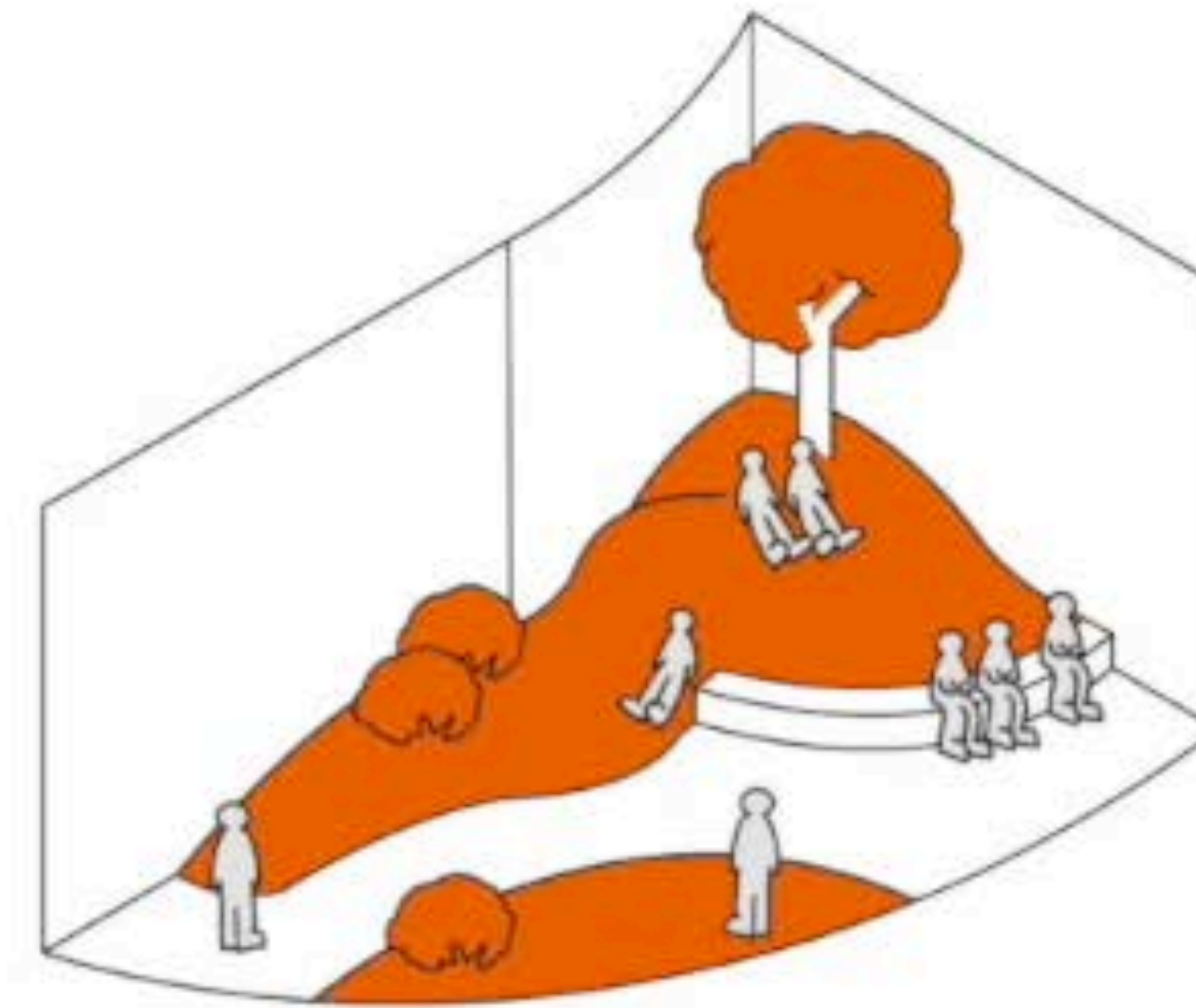

Vertical Street

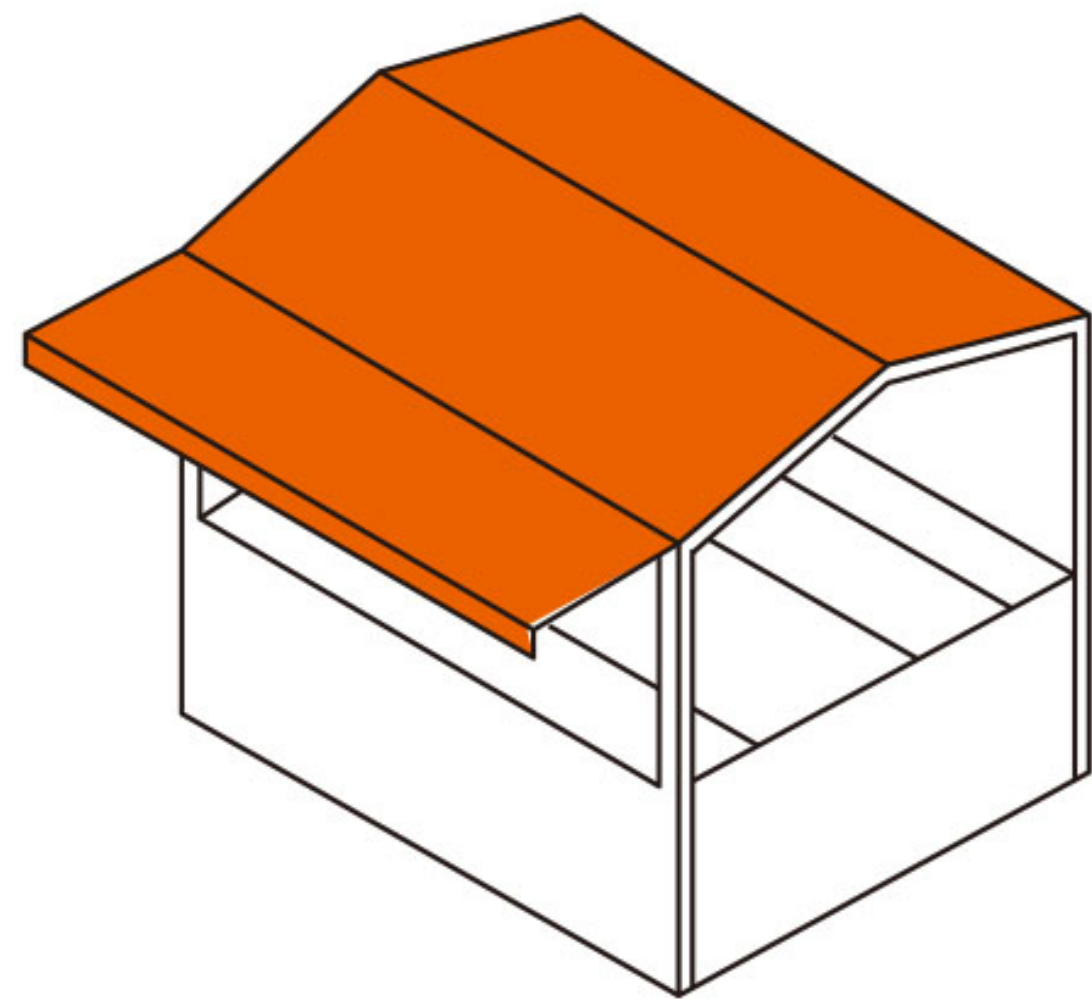

On street

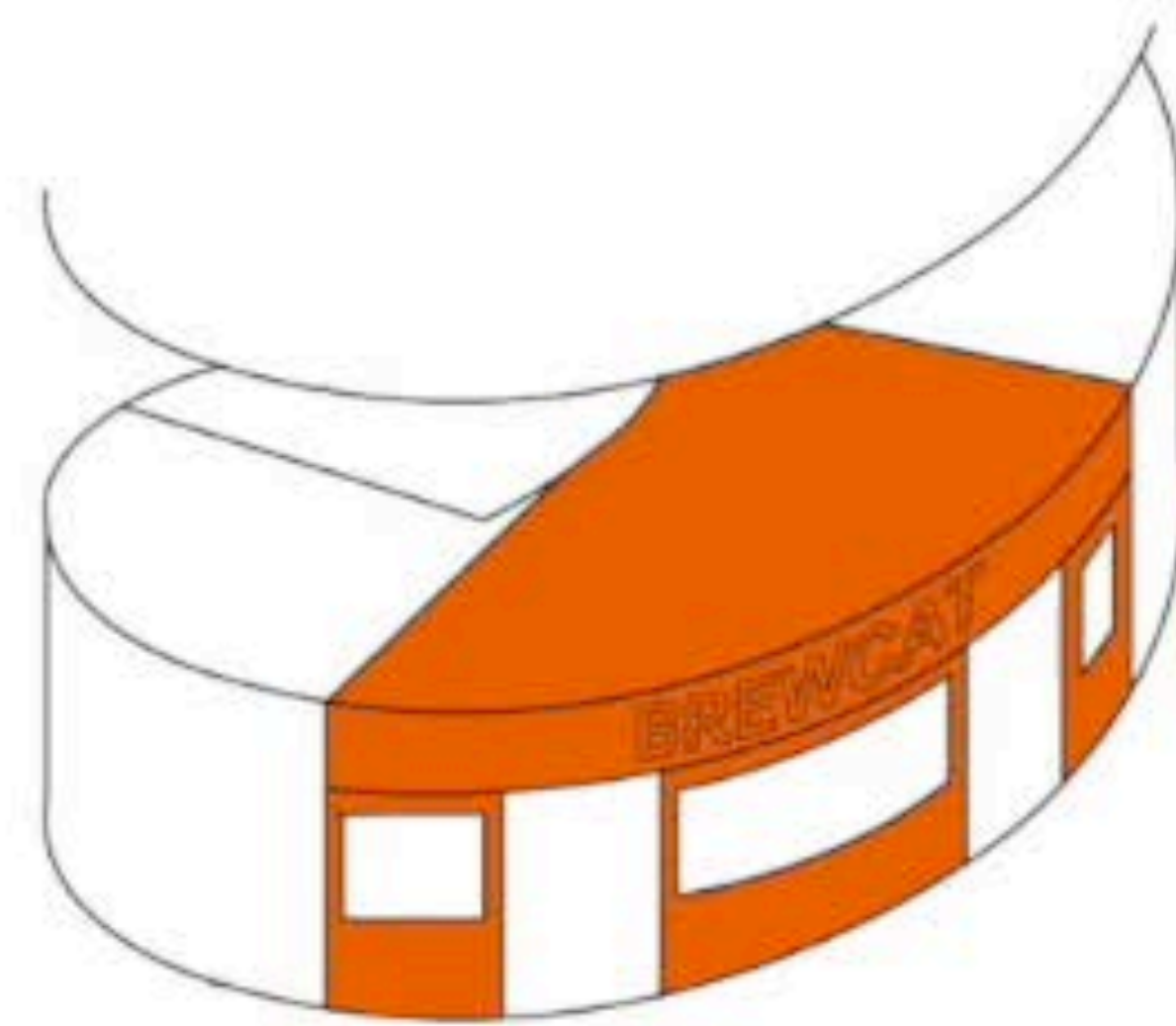

Vertical Street

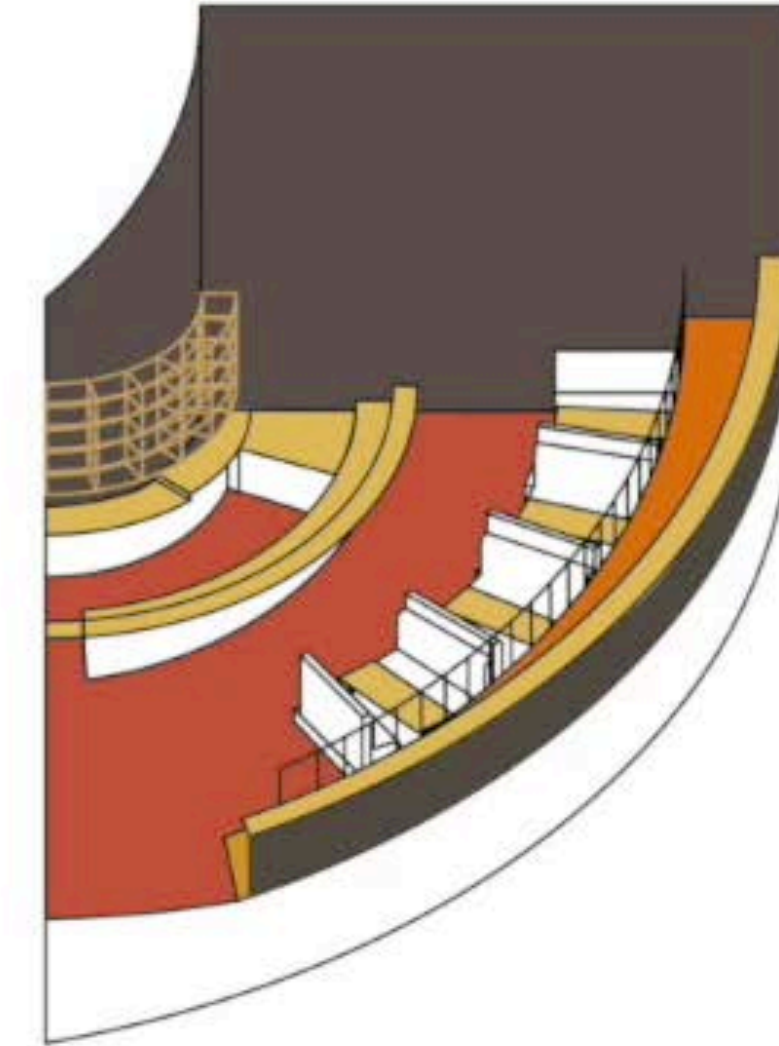
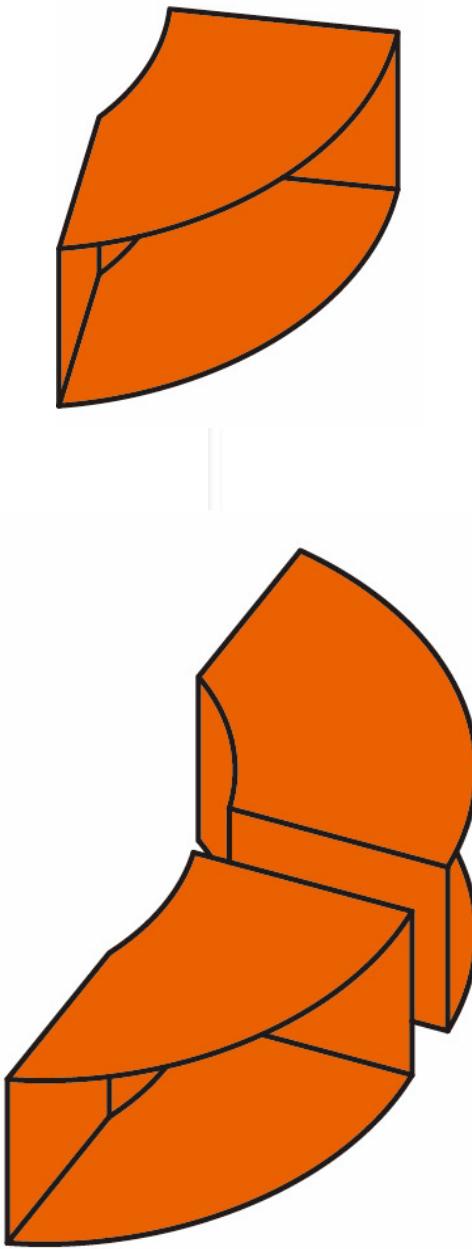
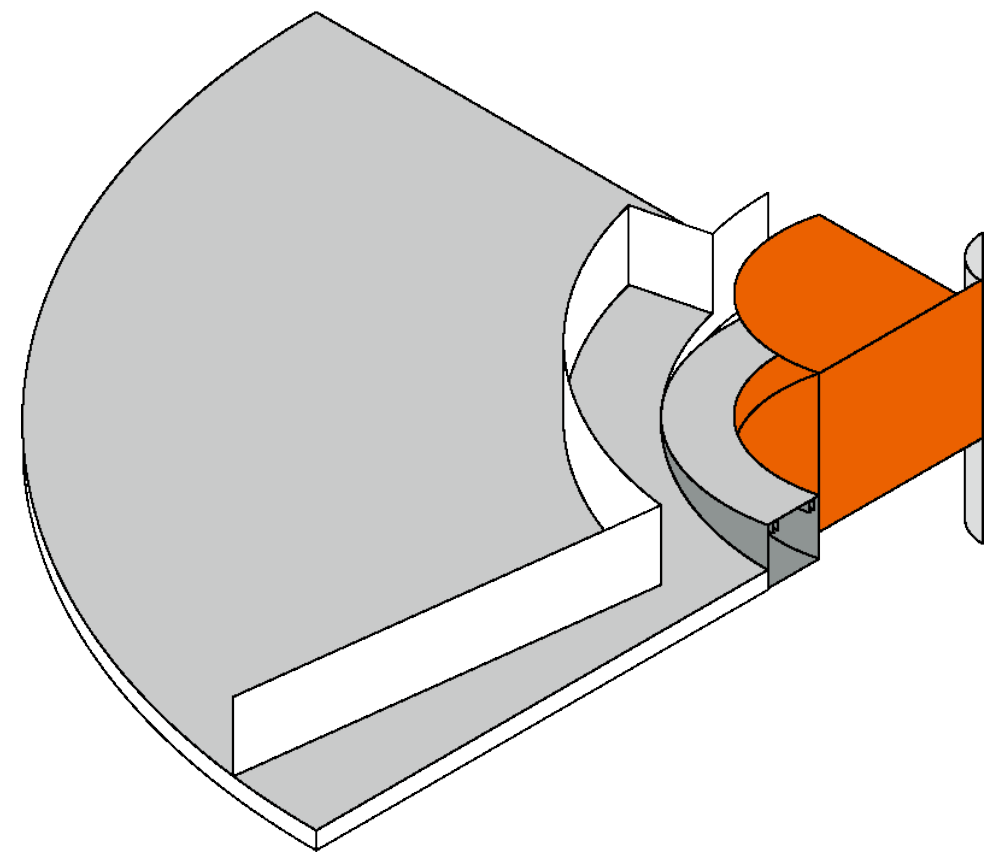

△ Standard Group

△ Combination

△ Amenity Unit

Amenity Unit :The Elements

Sofa Area

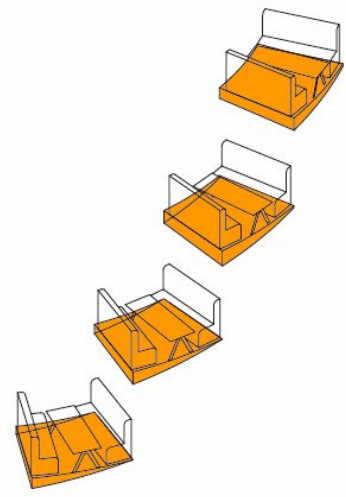

Sharing Area

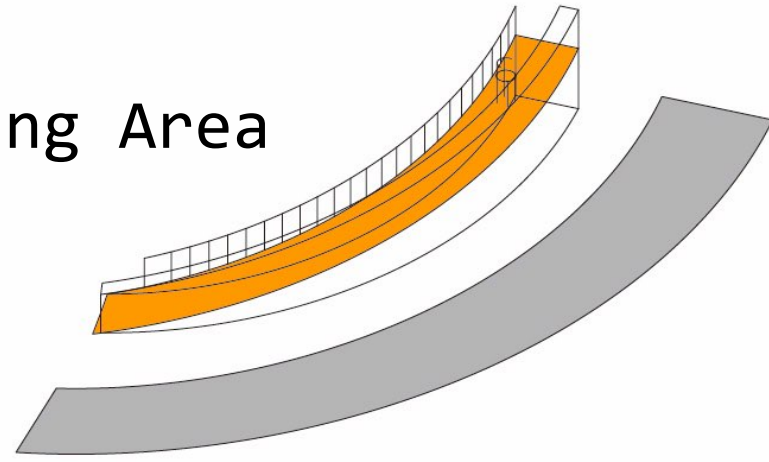

Bar Counter

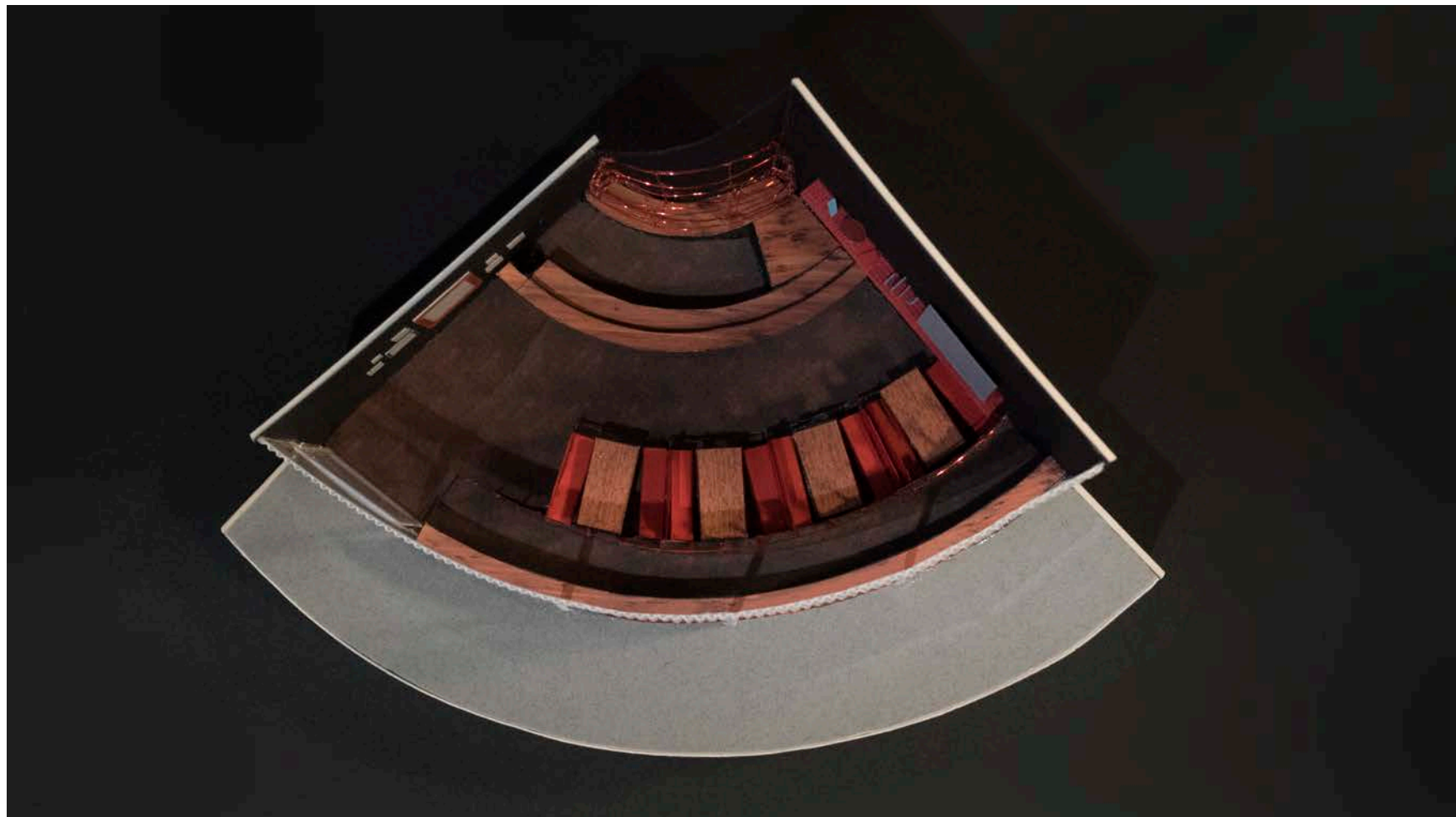
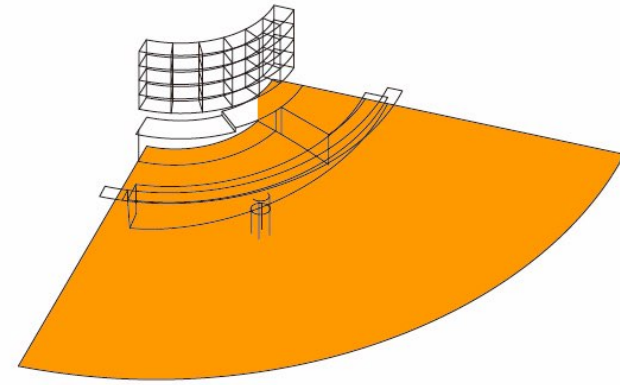

Amenity Unit :The Elements



Amenity Unit :The Elements

Preparation
Room

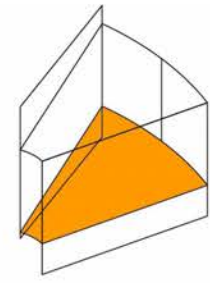

Church Room

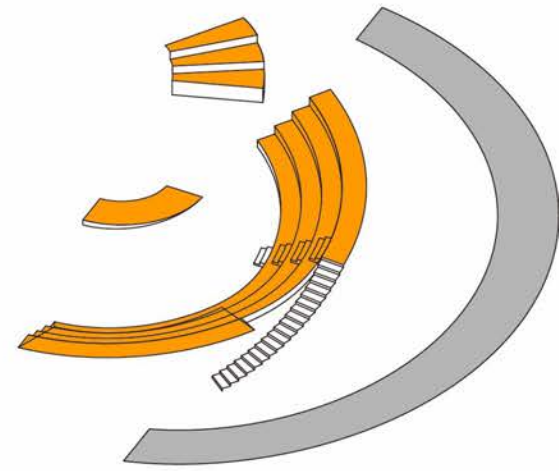

Activity Room
& Storage

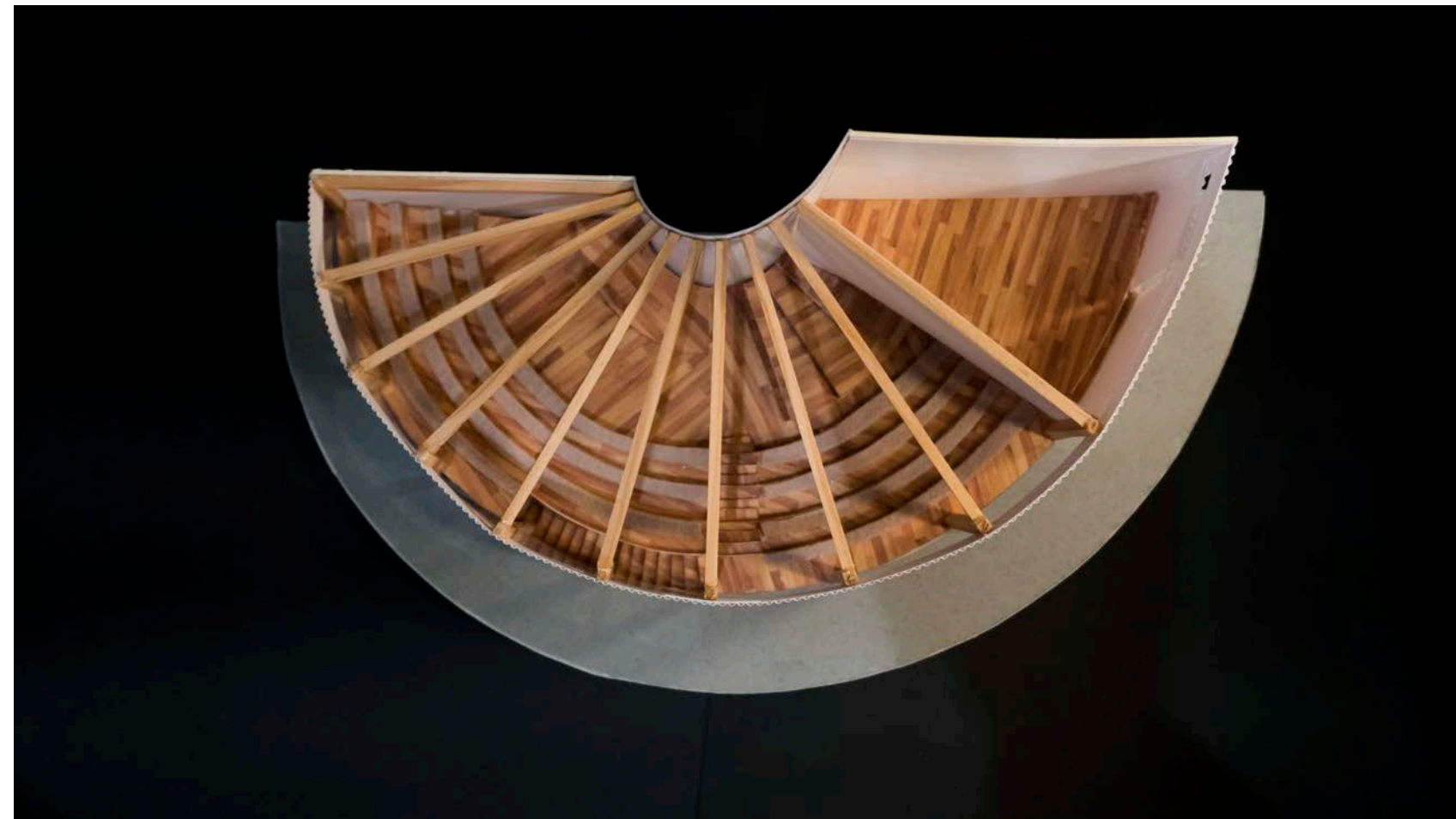
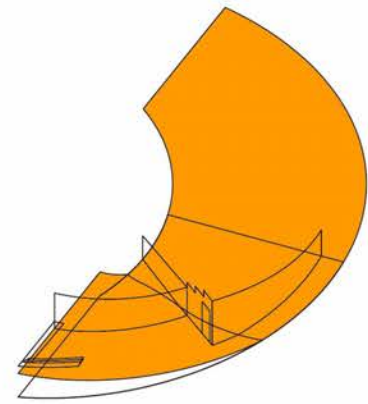

Amenity Unit :The Elements



Amenity Unit :The Elements

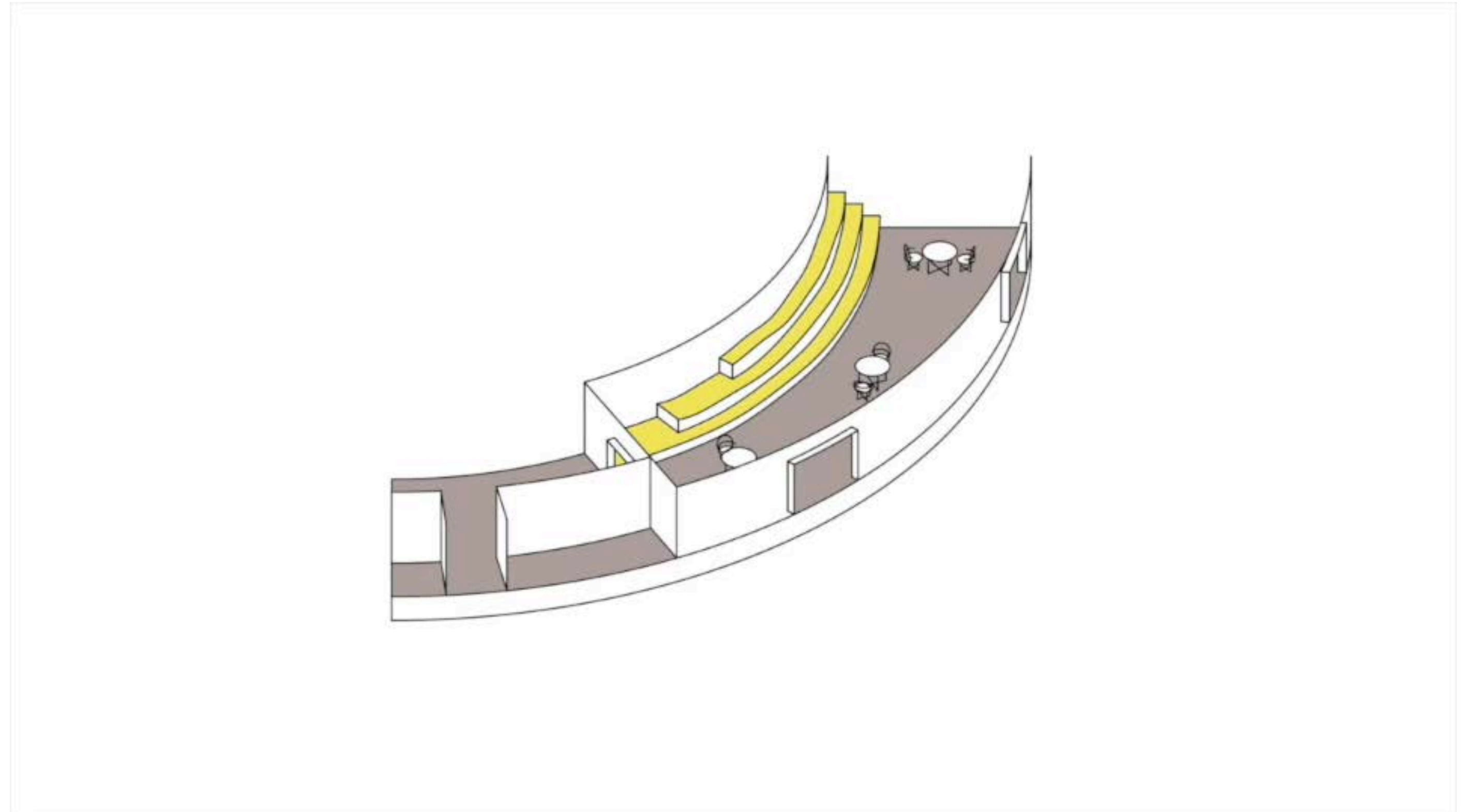
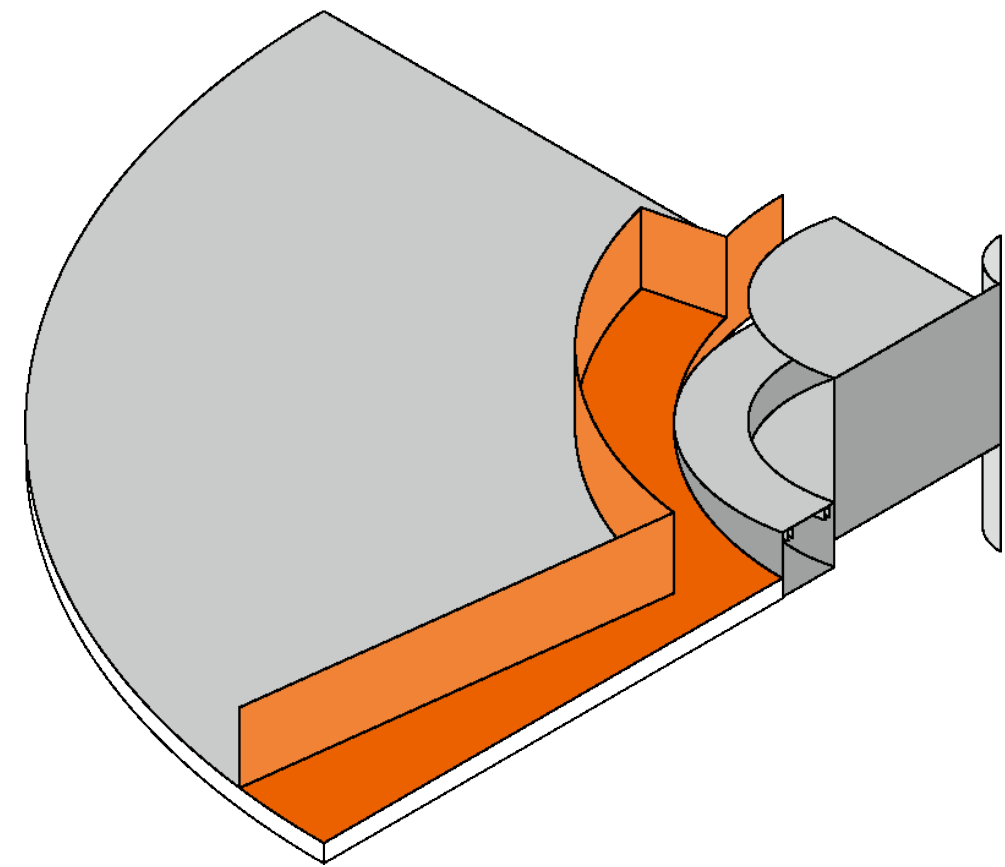

△ Standard Group

△ Setback

Setback :The Elements

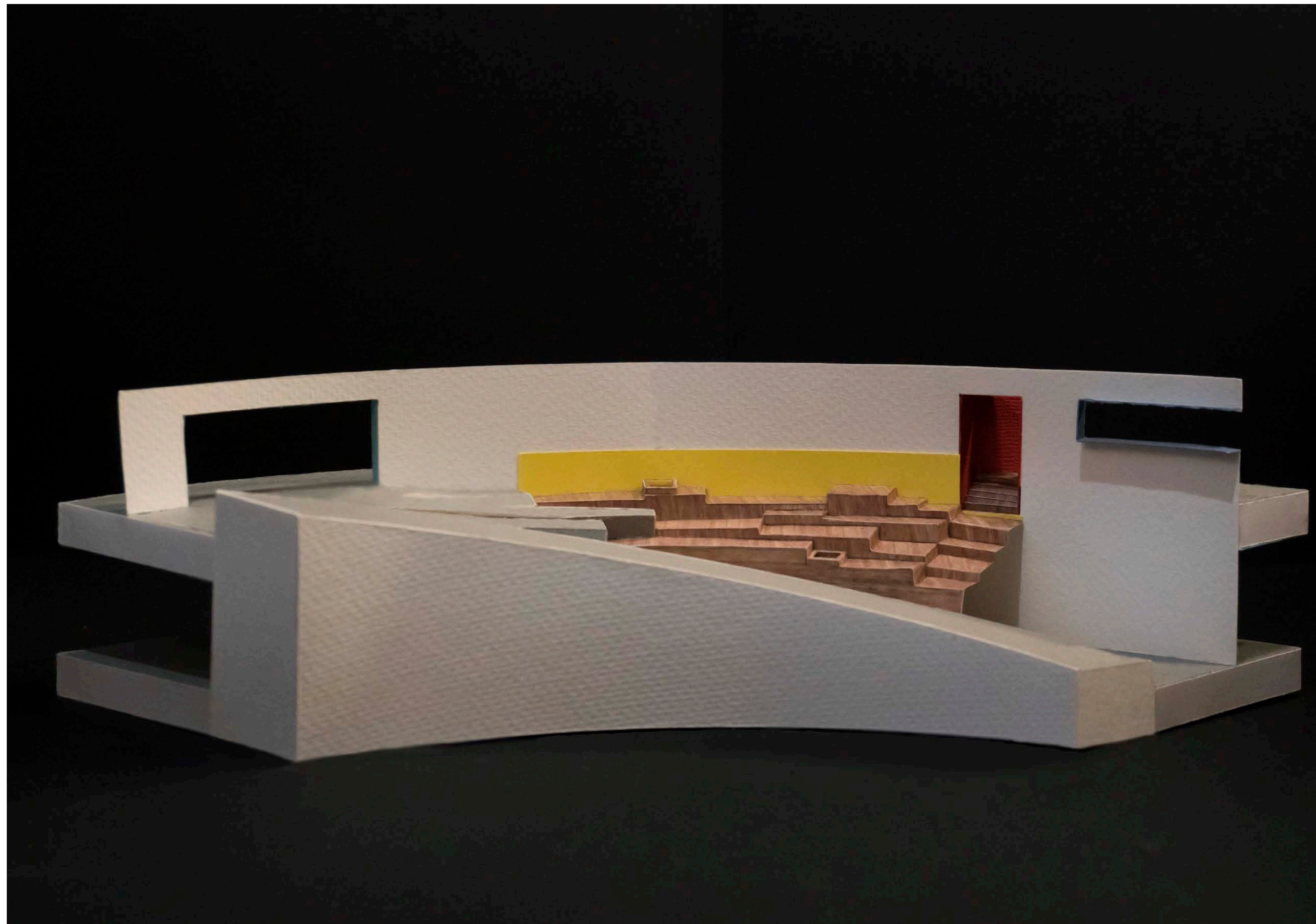
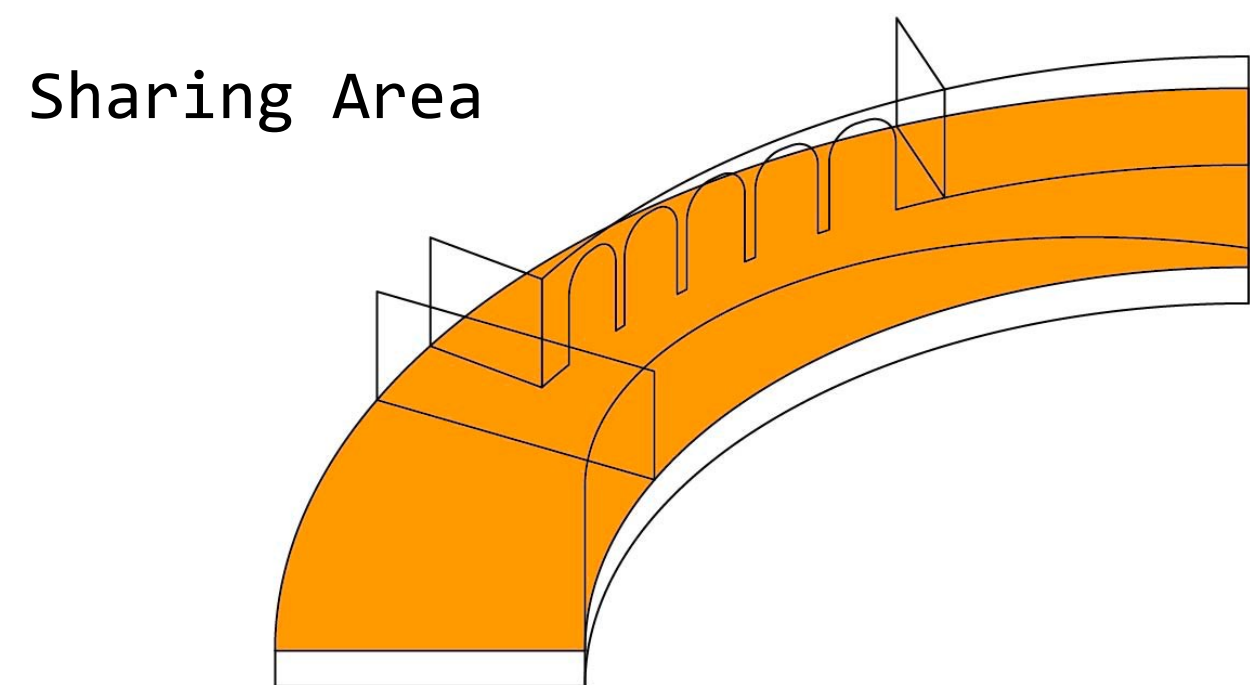
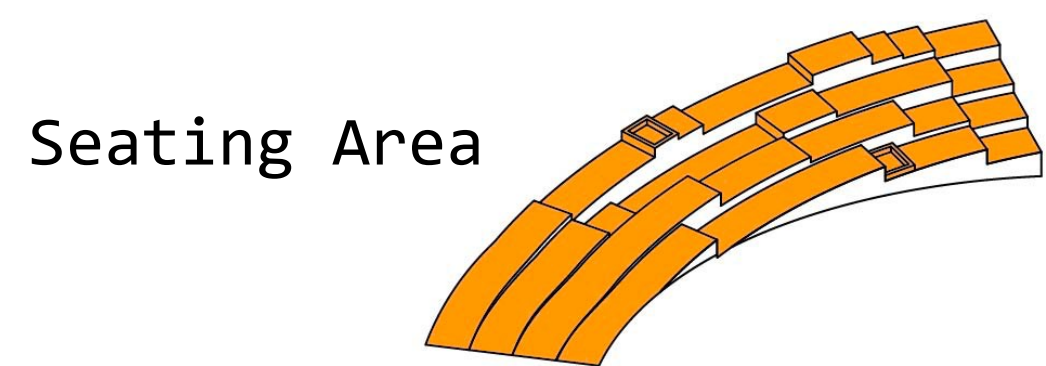
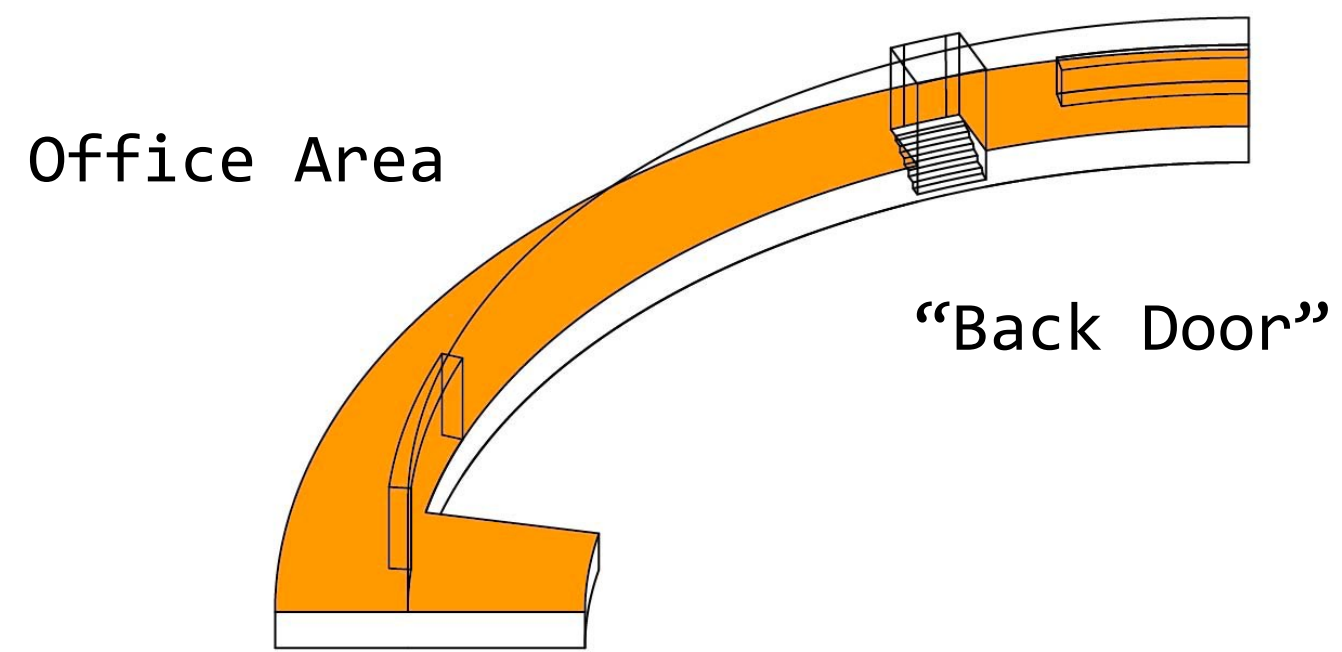

Setback :The Elements



Setback :The Elements

H-Train

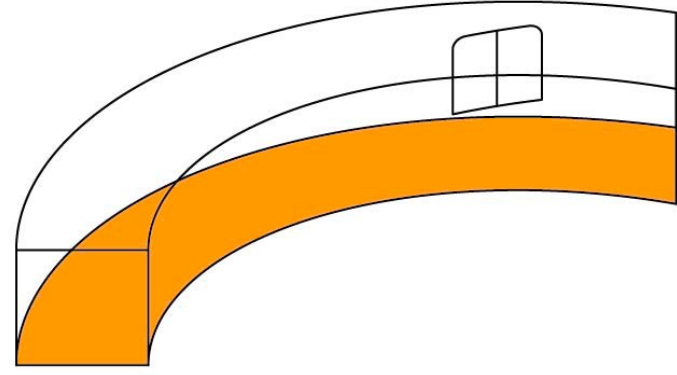

Terrace

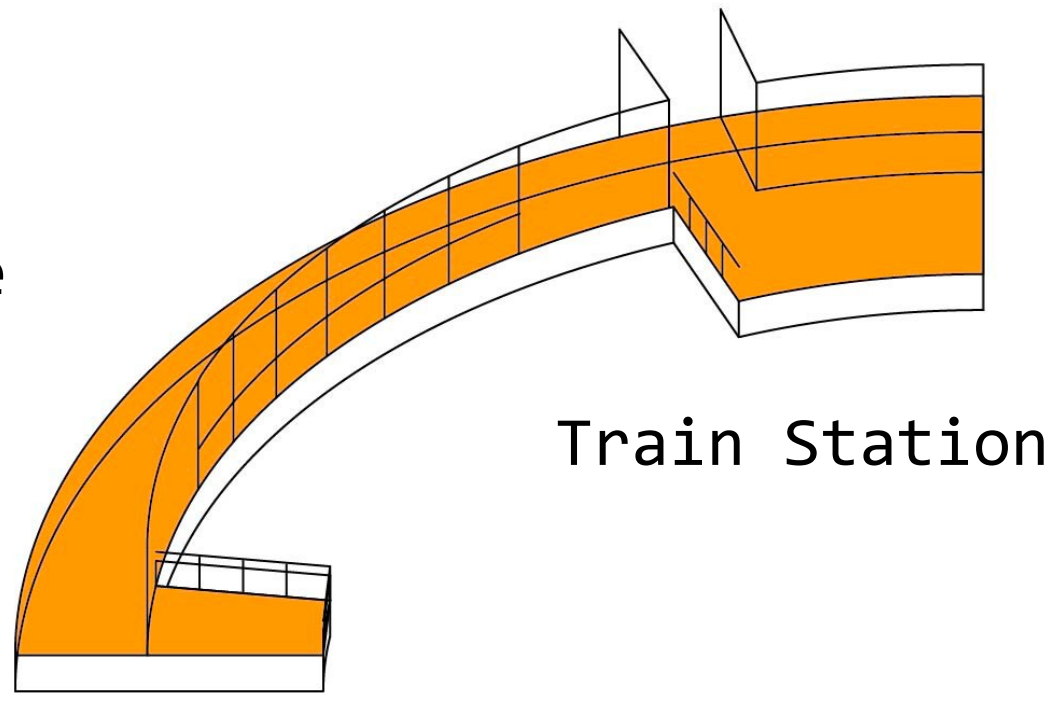

Garden

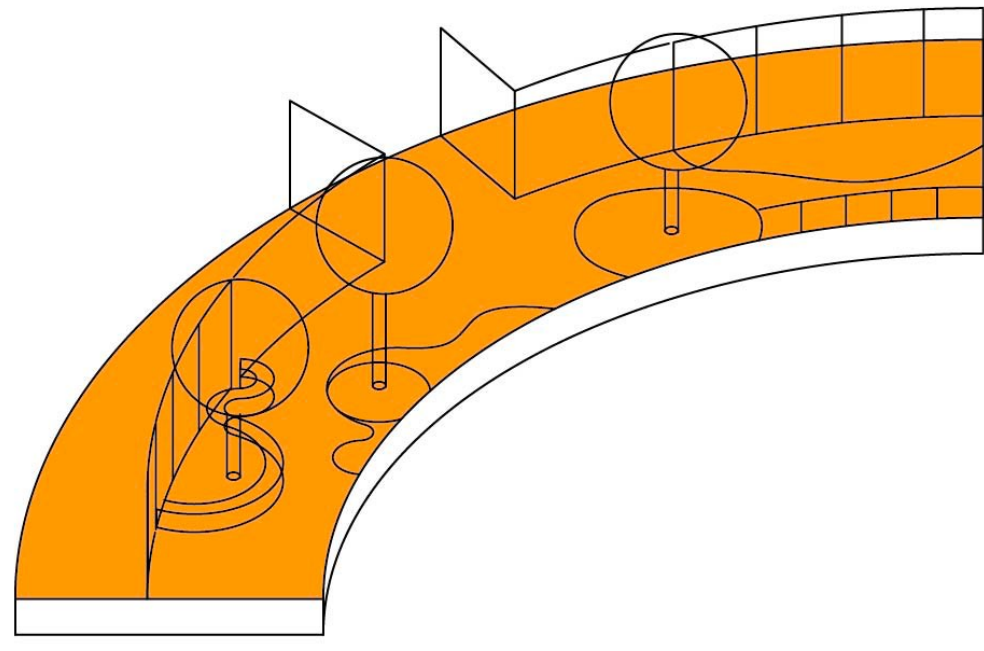

Setback :The Elements



Setback :The Elements



Ground level street



Threshold

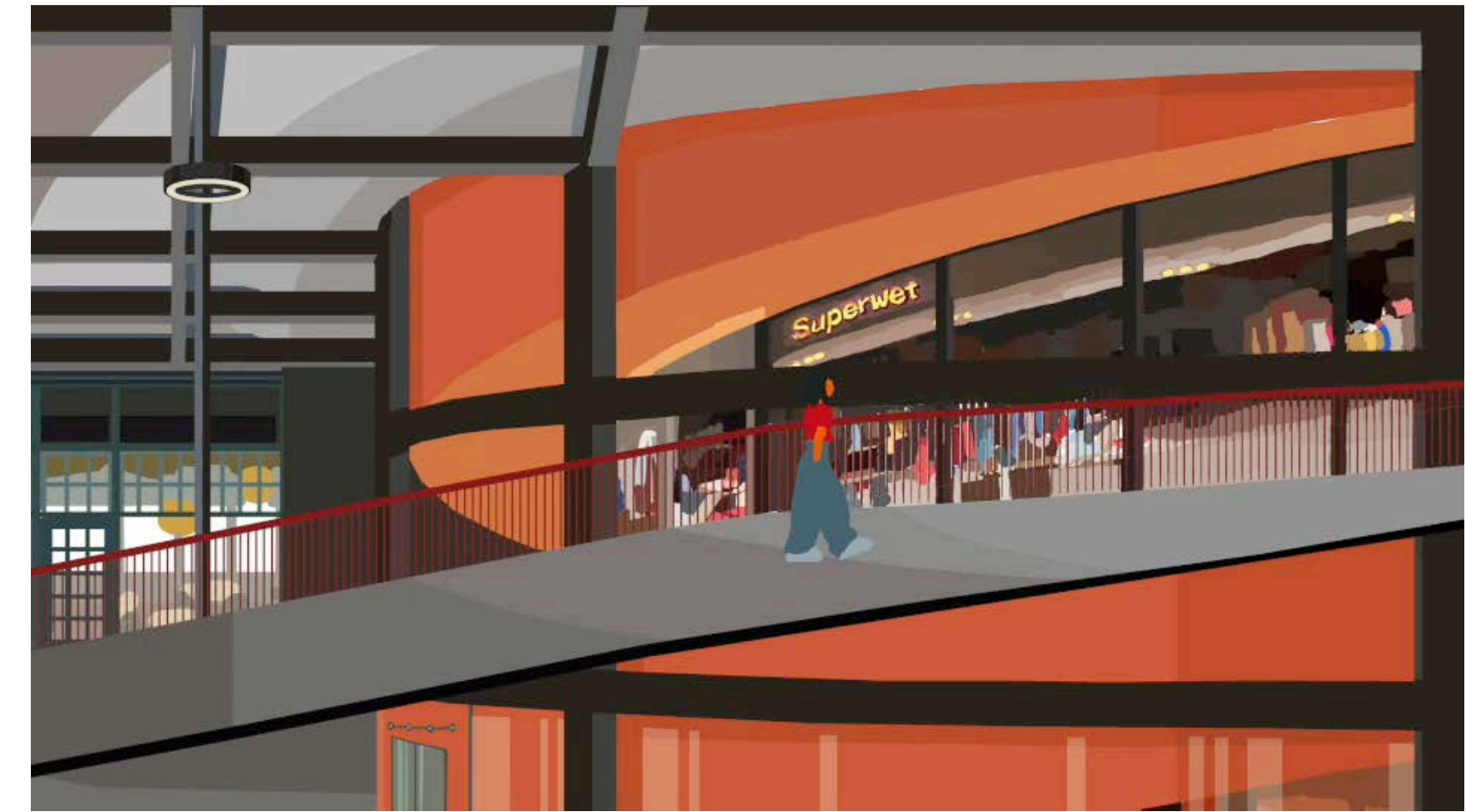

Approach the system



Pavement

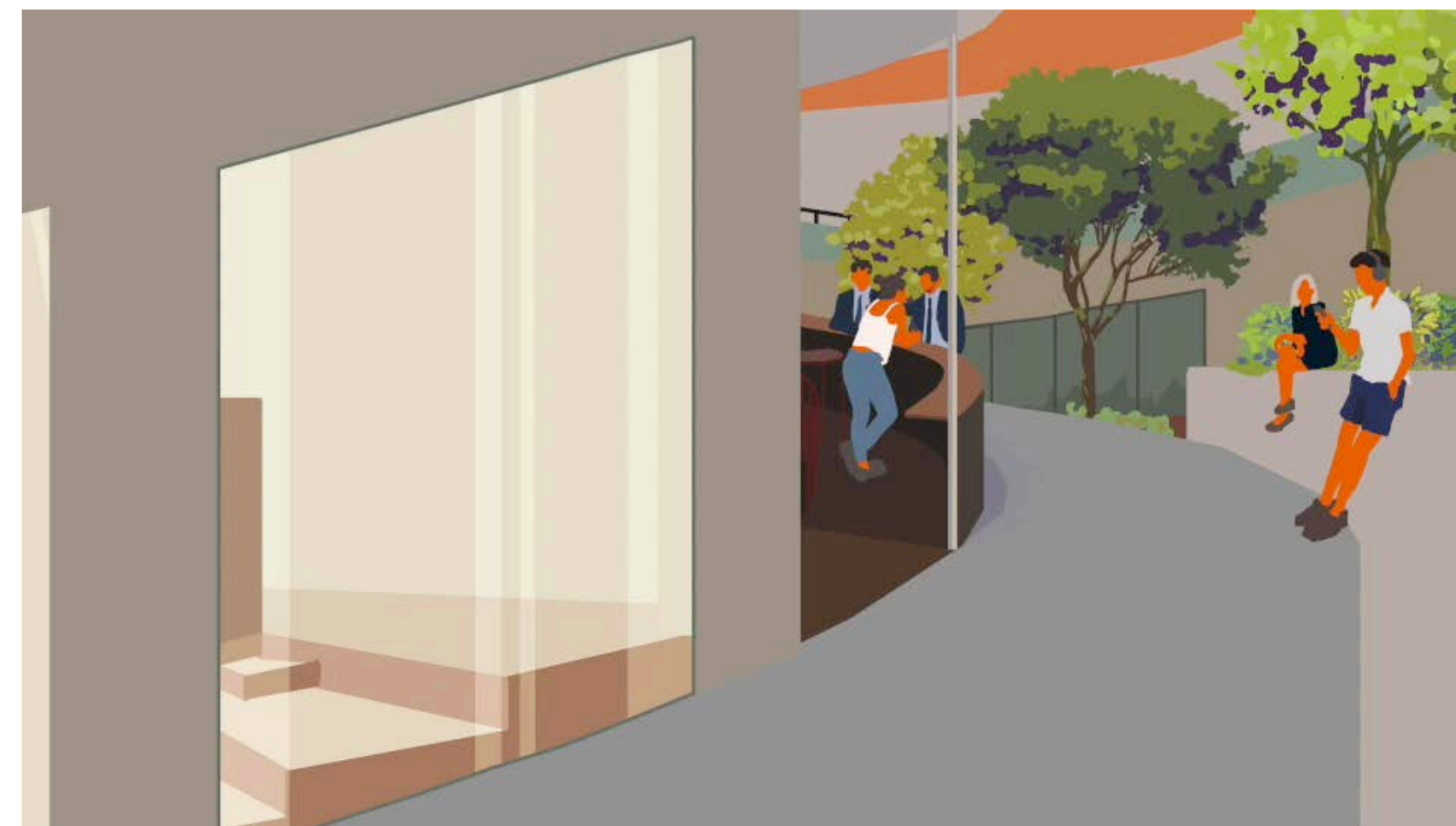

Atmosphere

Walking Experience

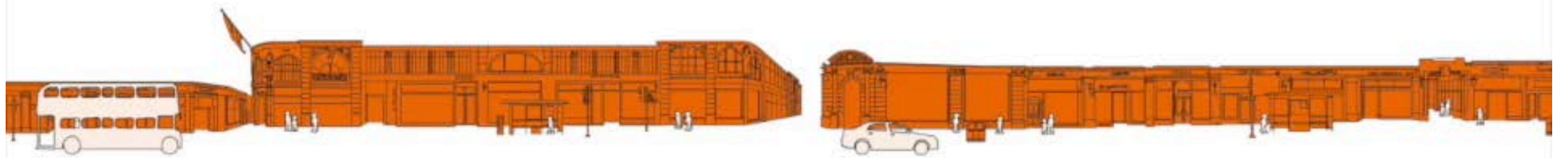

Thank You