



DUNGENESS

THE HEADLAND OF MUSIC
BY THE ROMNEY. HYTHE



Timeline of Dungeness

1883



Opening of the
Railway Station

1901

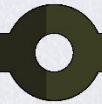

Construction of the
150 ft Lighthouse

1937

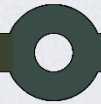

Closure of the
Railway Station

1960



-Fishing in Dungeness
-Closure of the
lighthouse

1965



Opening of the
Power Station

2006

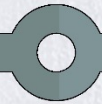

Closure of the
Power Station

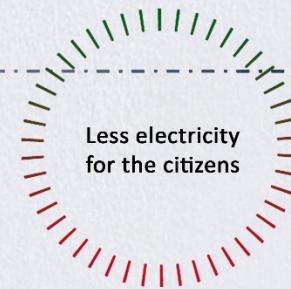

DUNGENESS STATION

1910



1919



1932



1962



2006





Dungeness is dying...



Leading to ... **DESERTIFICATION**

DESERTIFICATION



Sound Mirrors

Dungeness



SOUND MIRRORS





200 FT SOUND MIRROR

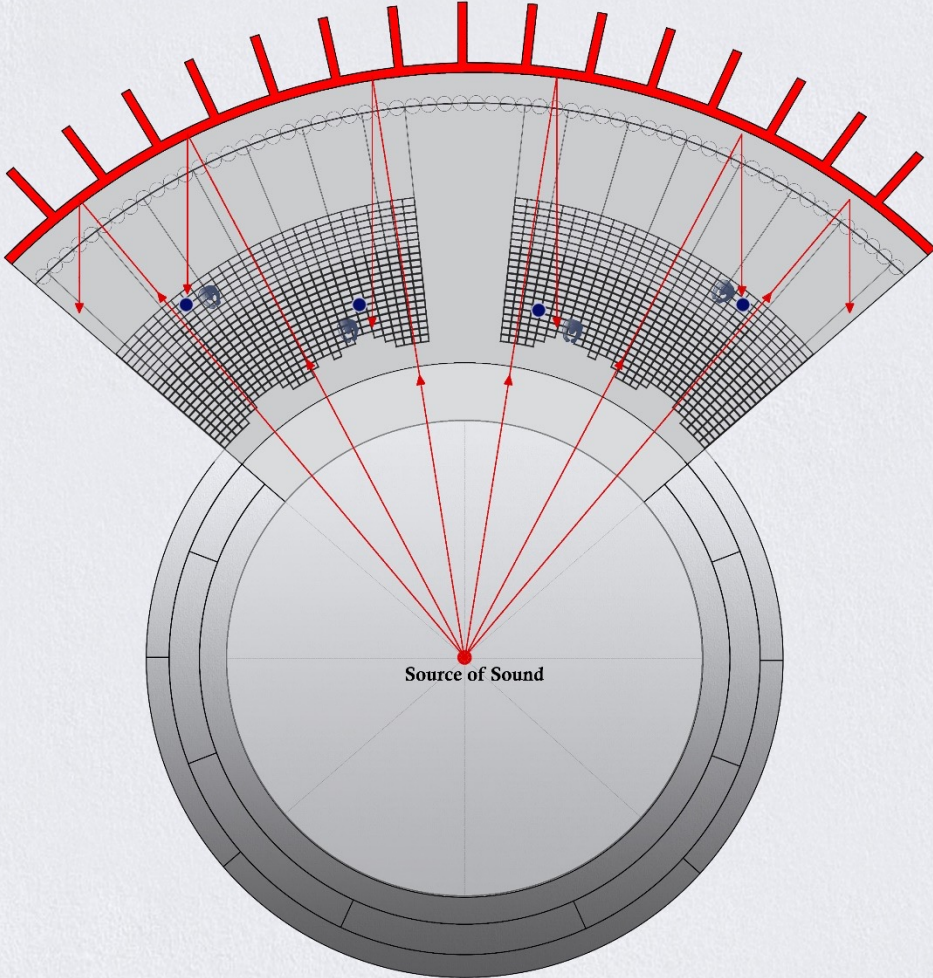

● Impact

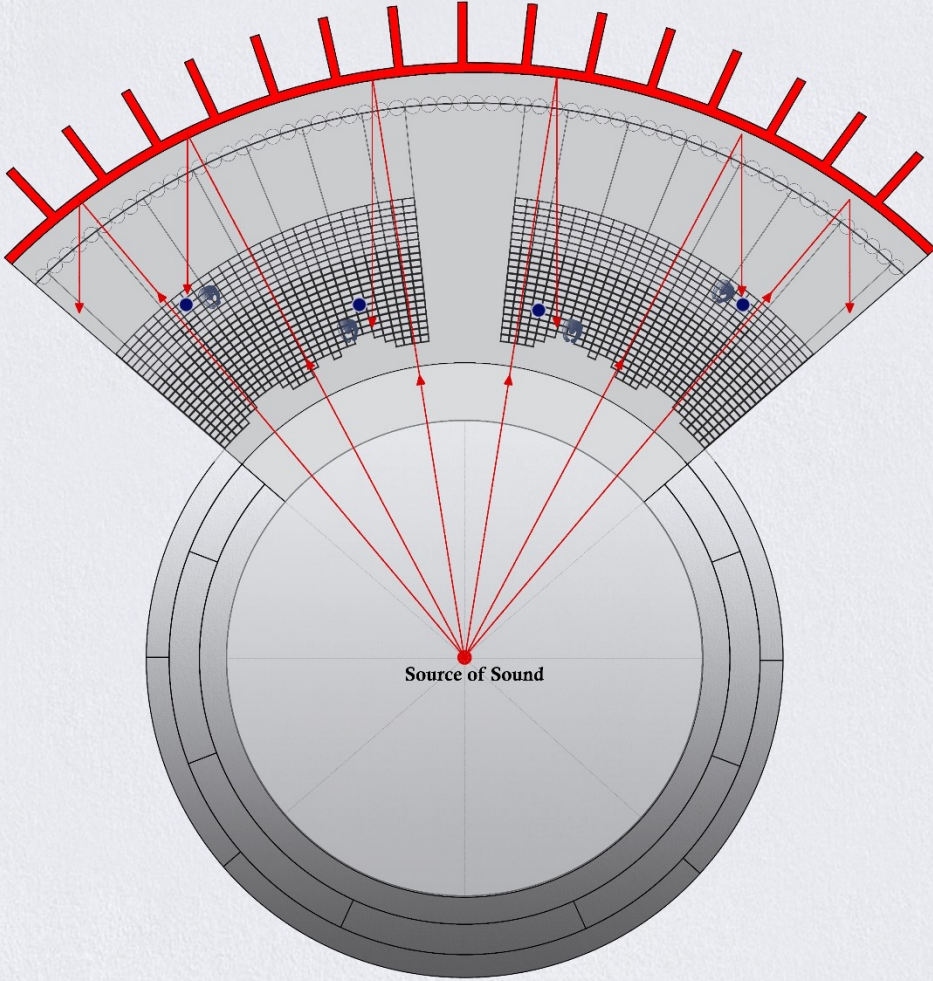

● Impact



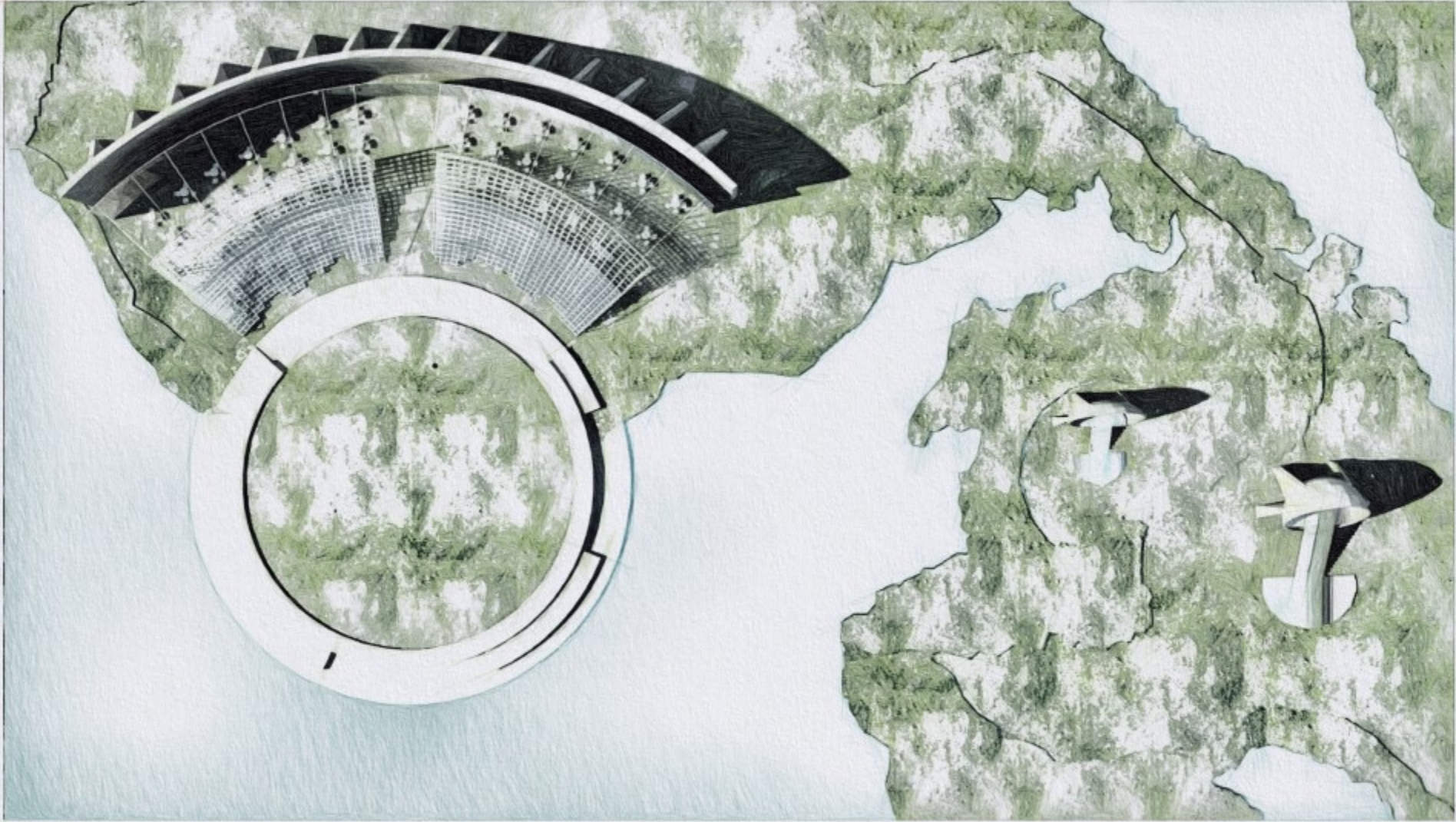

SITE LOCATION PROPOSITION

An aerial photograph of a coastline. The left side shows a light blue body of water meeting a white sandy beach. To the right of the beach is a road that curves along the shore. There are several trees and green spaces along the road. The land beyond the road is a mix of light green and tan, suggesting a natural or undeveloped area.

THE PROPOSAL

- A unique performance location
- Cinema, theatre, opera, poetry, live music
- Combines sound of nature & performance sound
- Revitalizes Dungeness as a destination



Higher Frequency

Lower Frequency

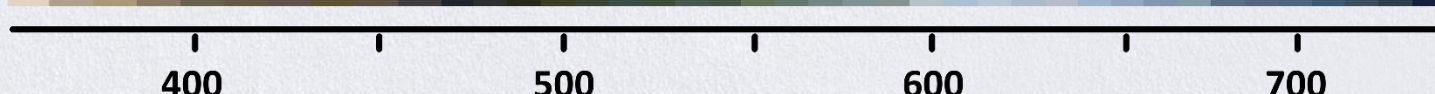
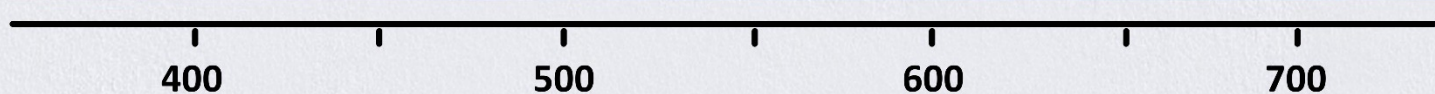
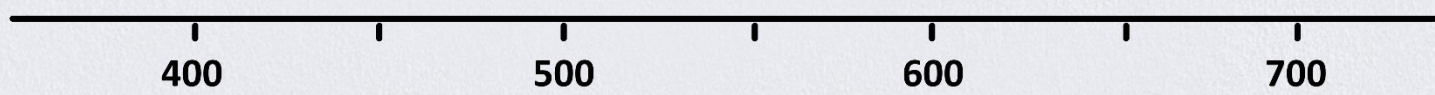
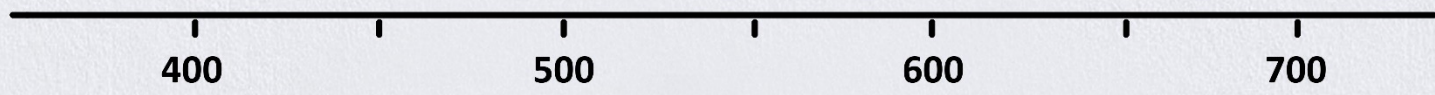
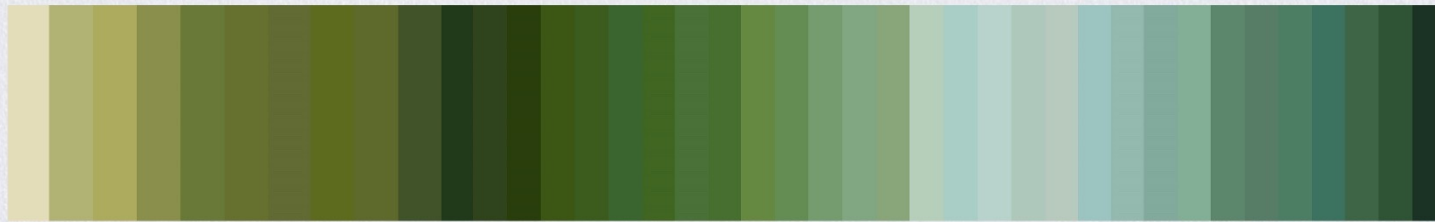

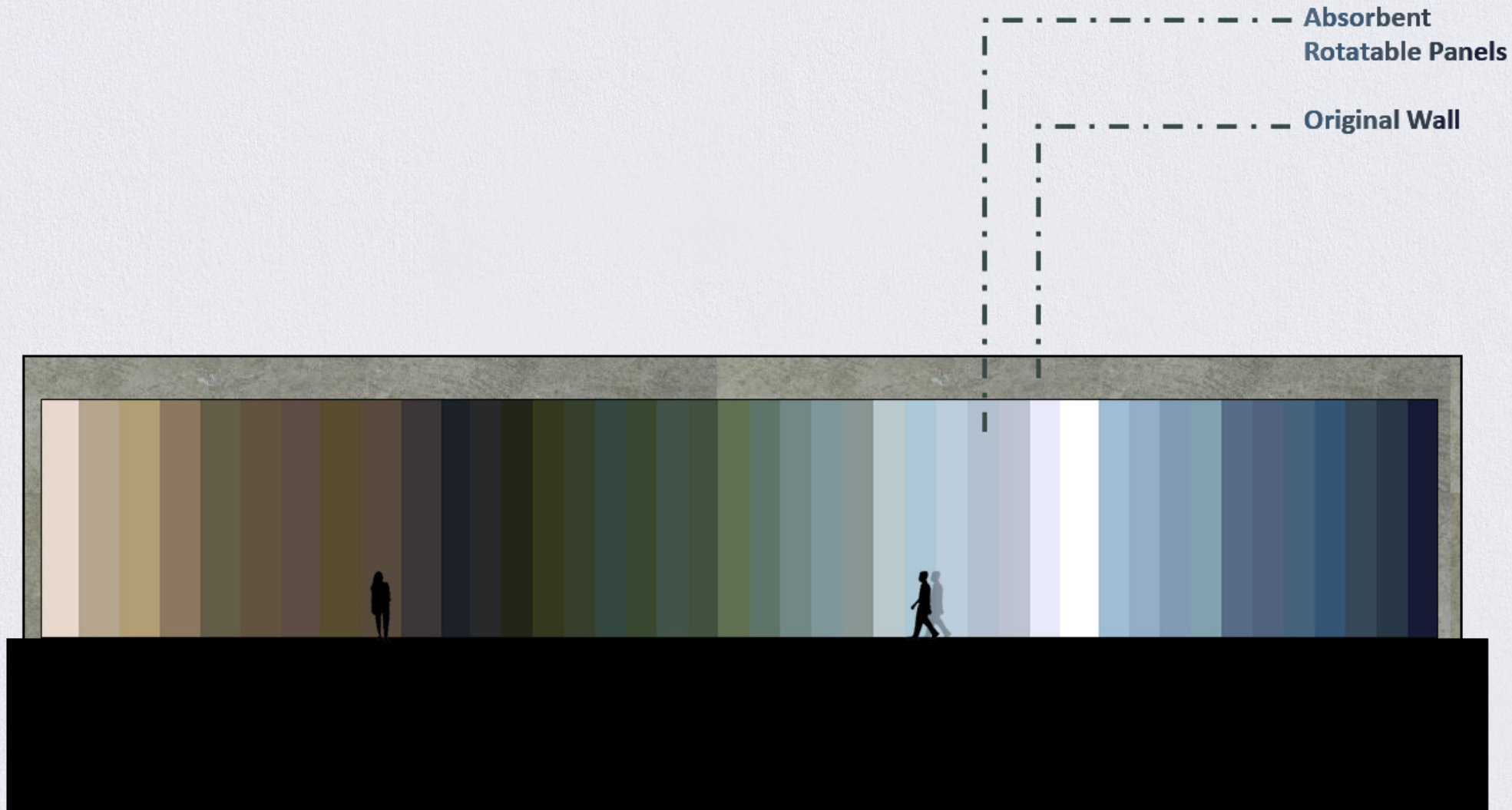

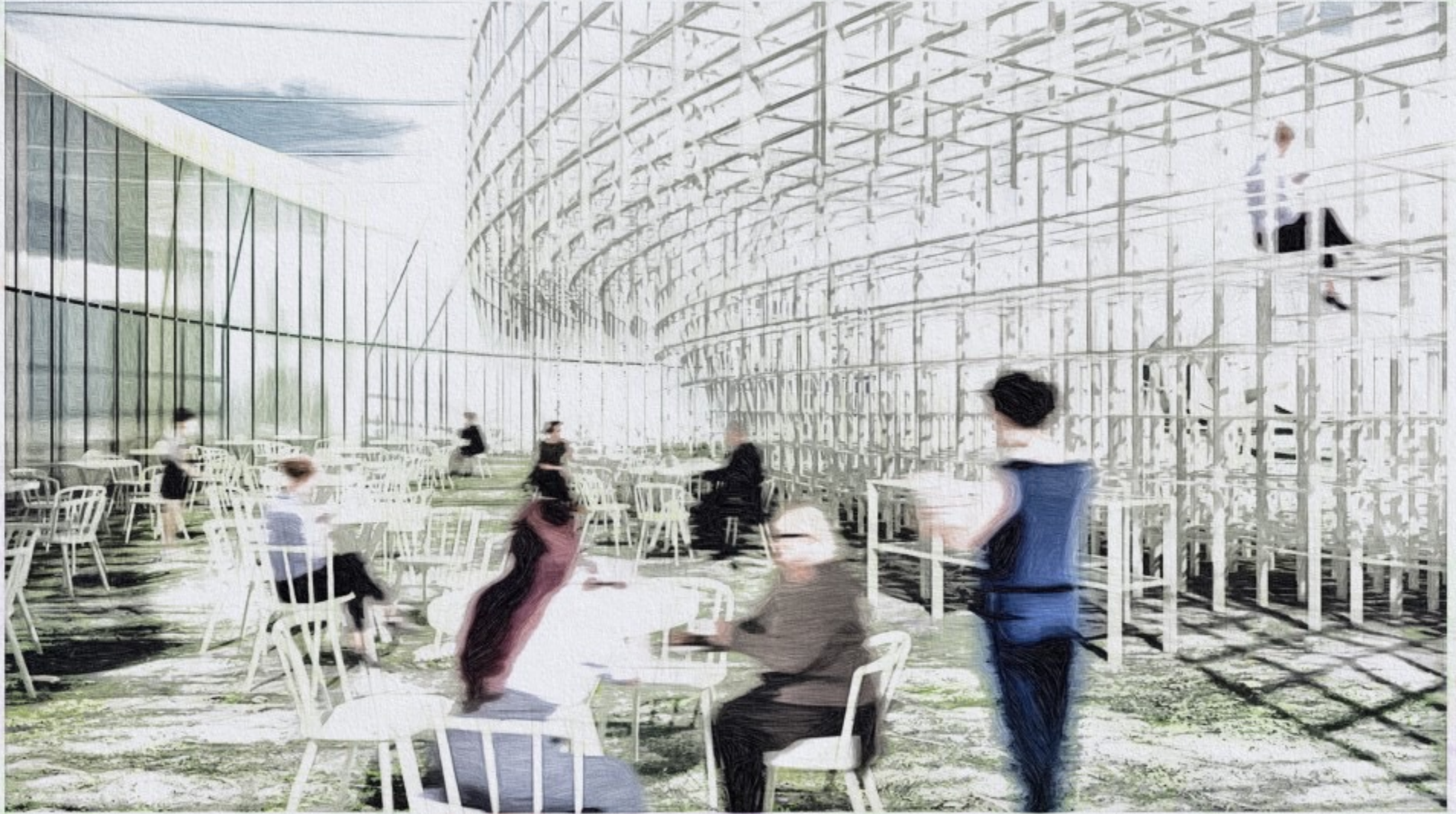

COFFEE AREA – RESTAURANT

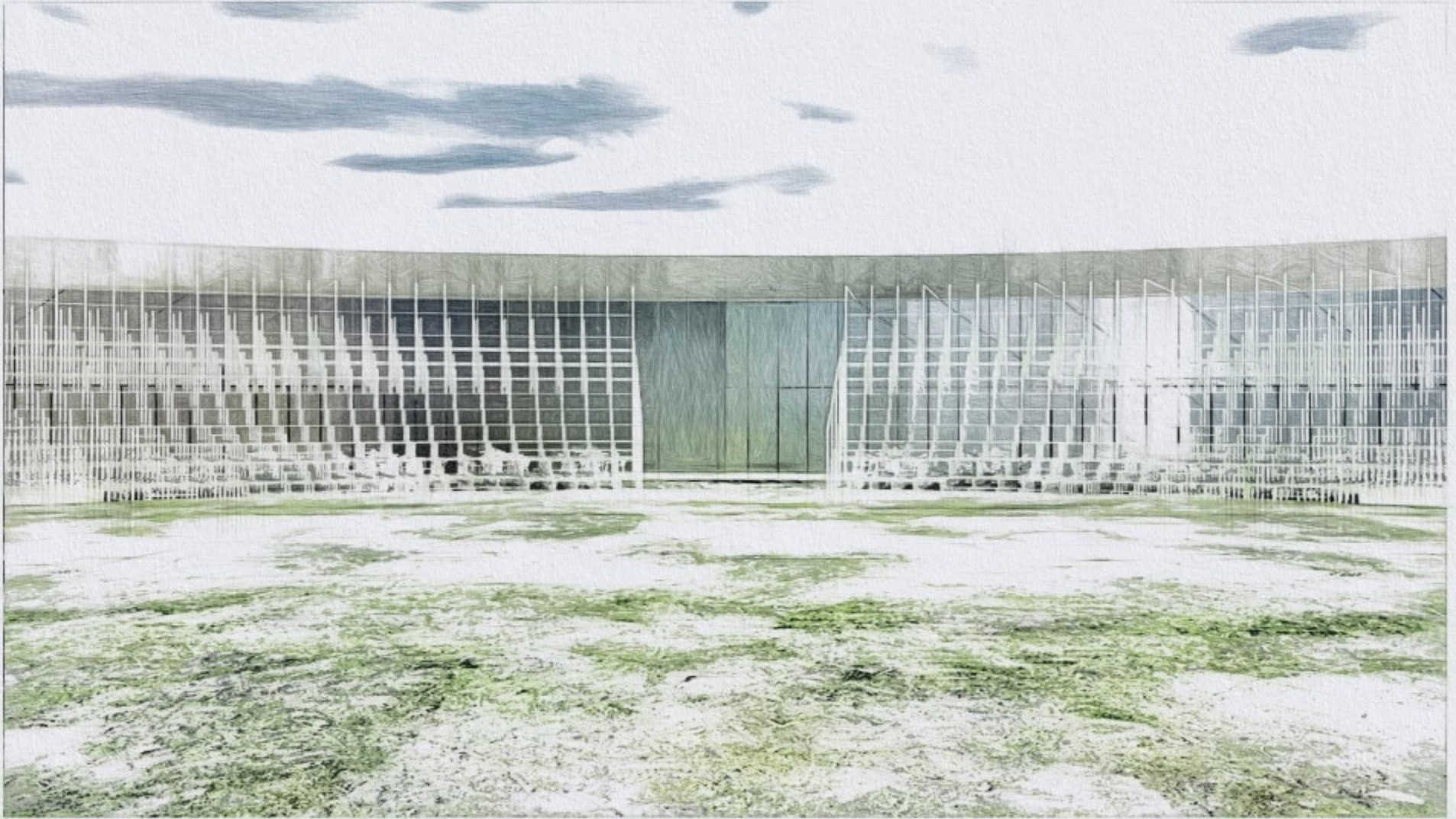

THEATRE



STAIRCASE DESIGN

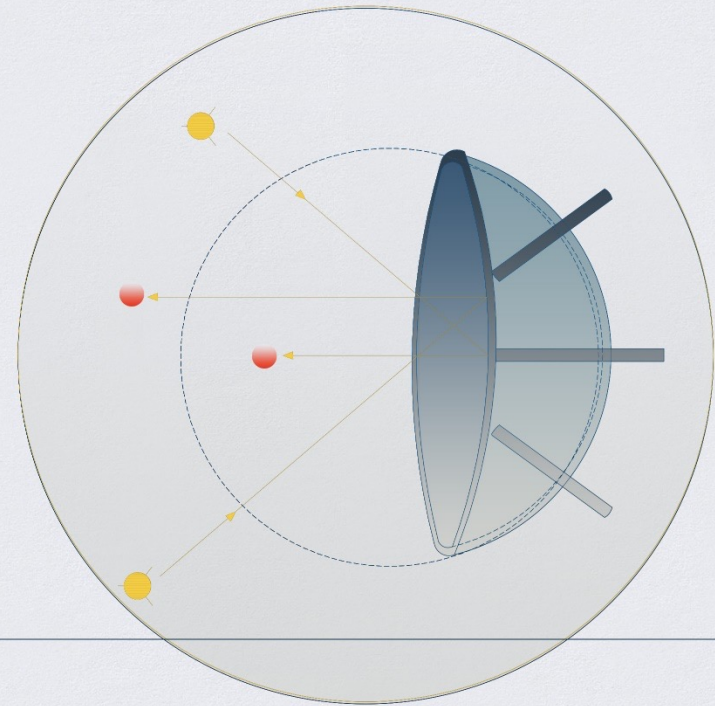
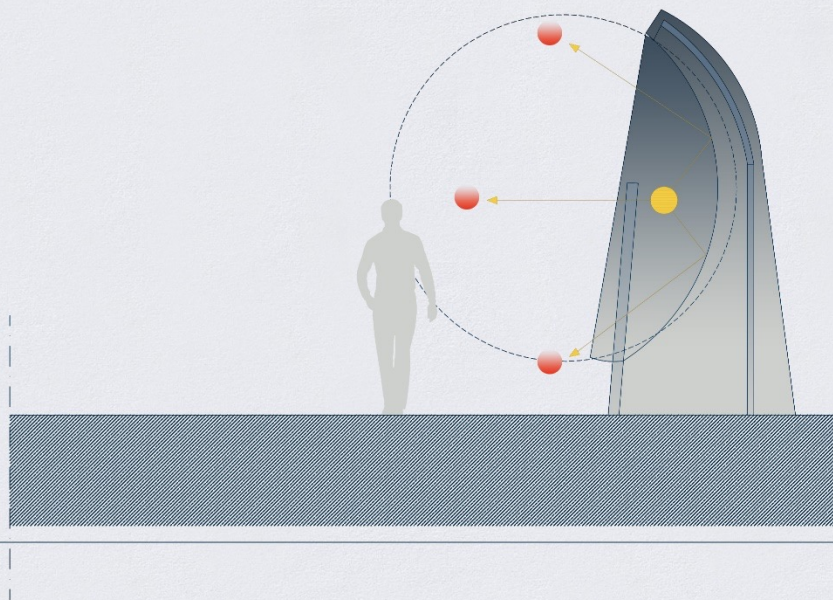

● SOURCE OF SOUND

● IMPACT

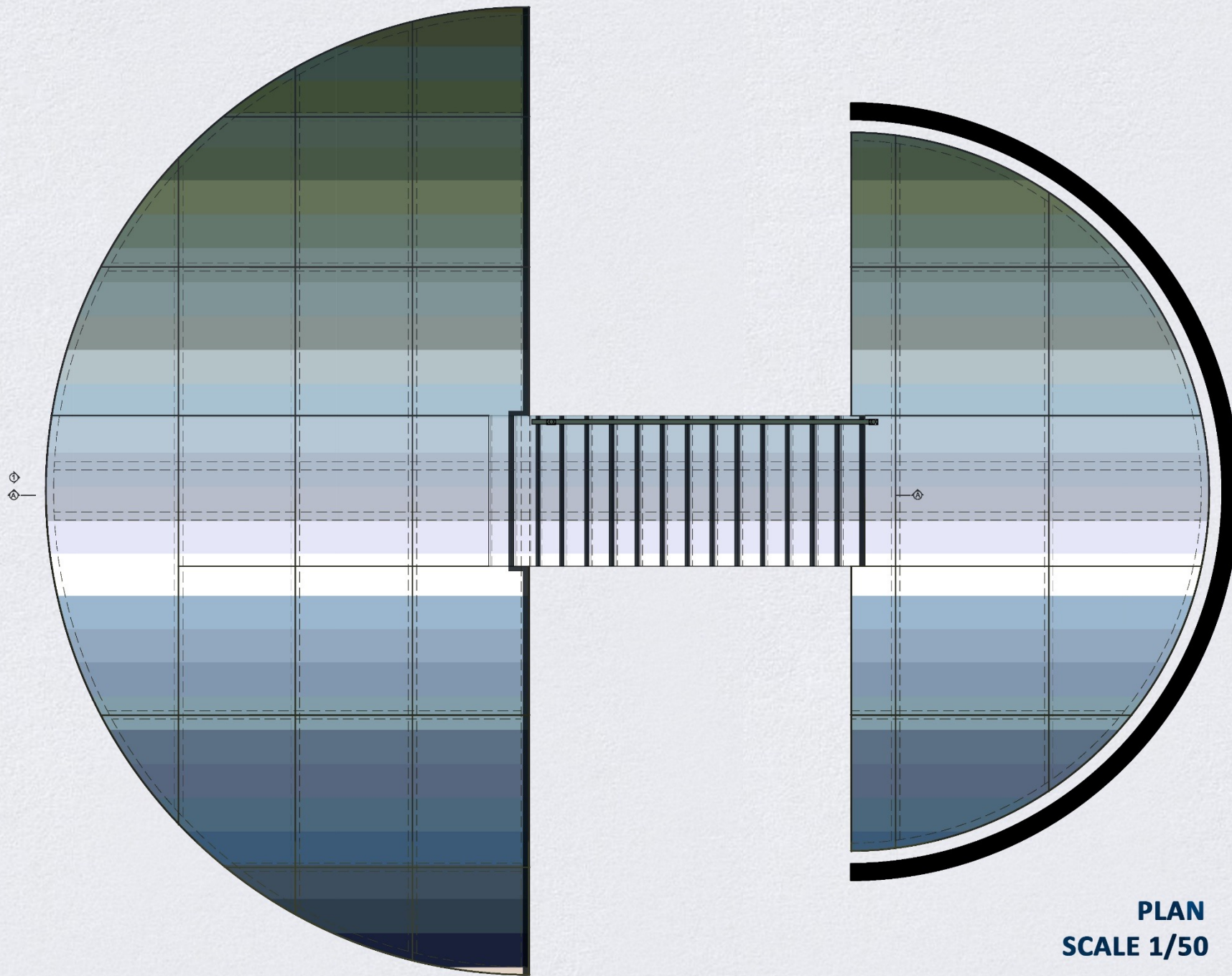

PLAN
SCALE 1/50

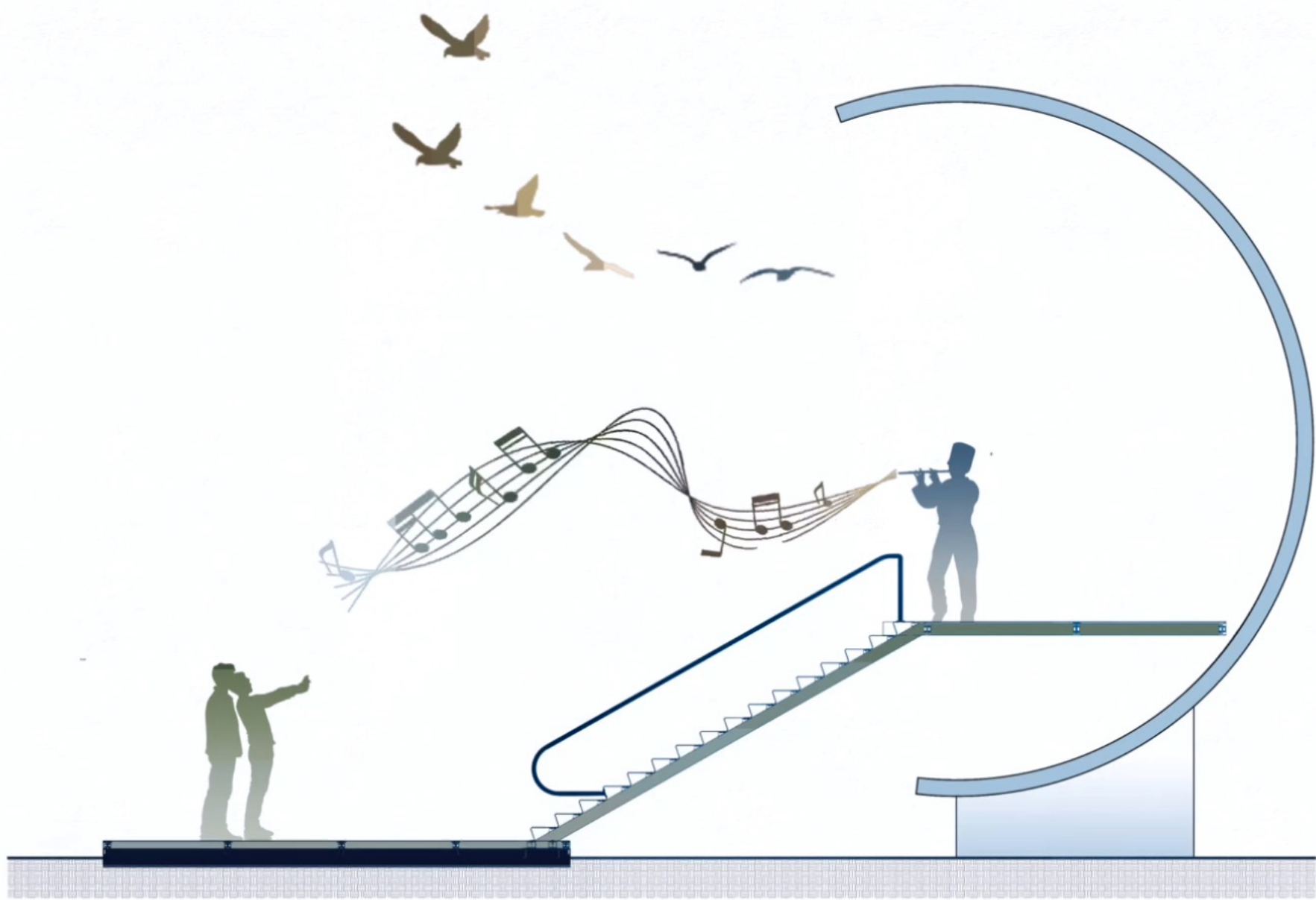

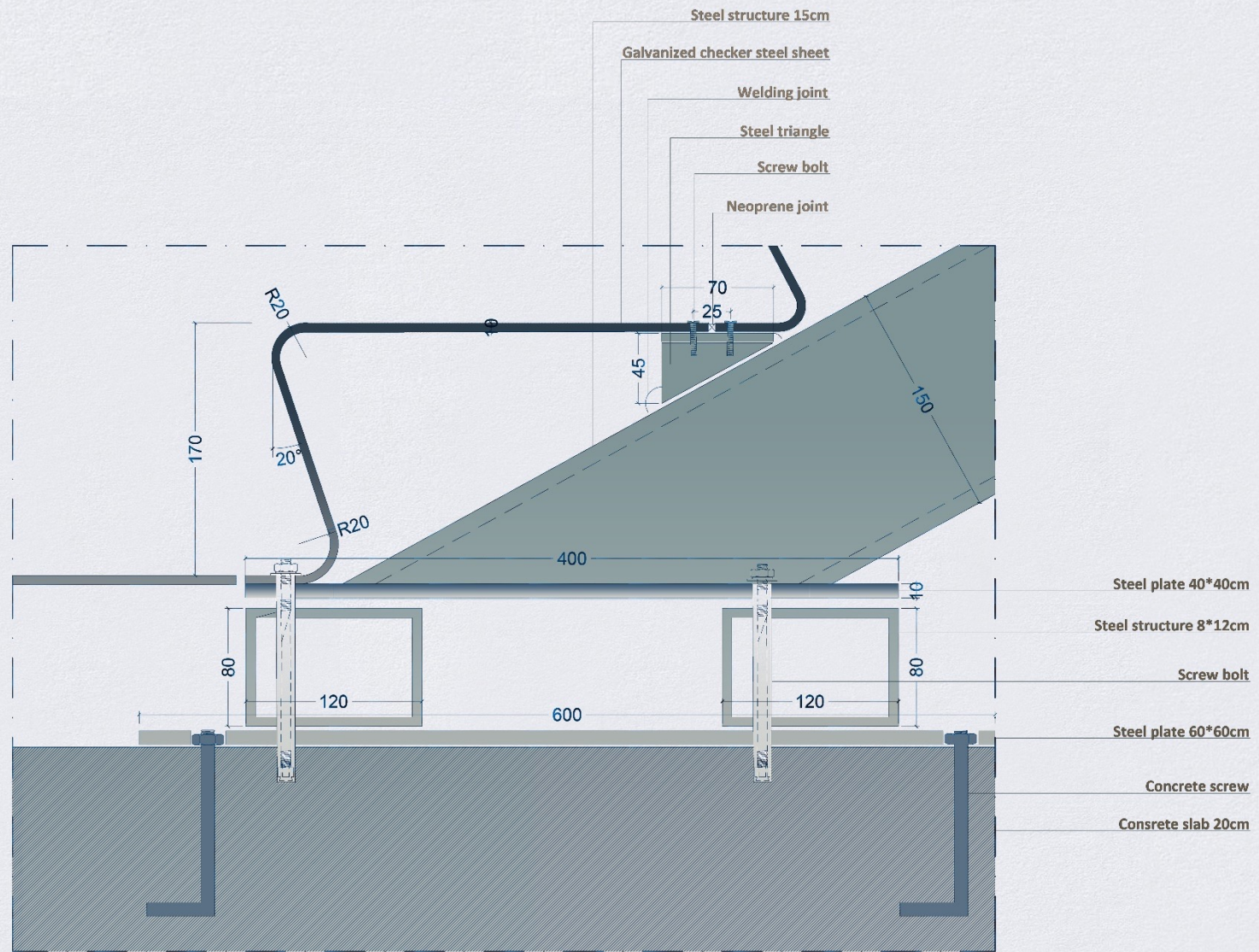

DETAIL 1
SCALE 1/1

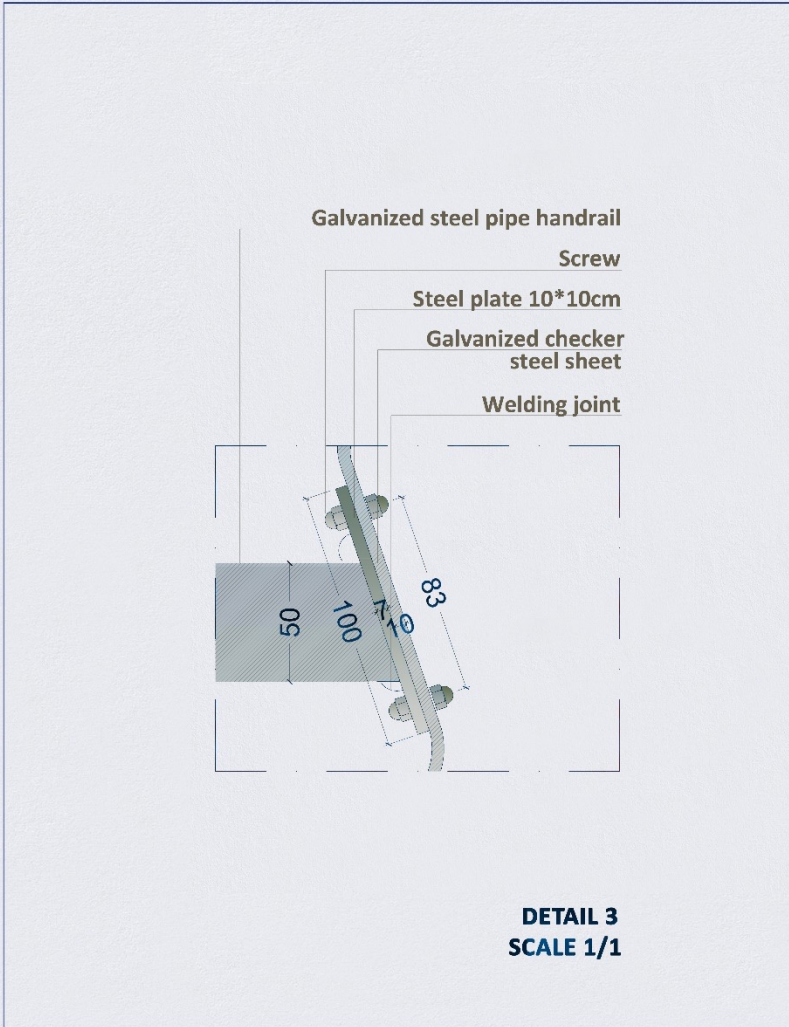
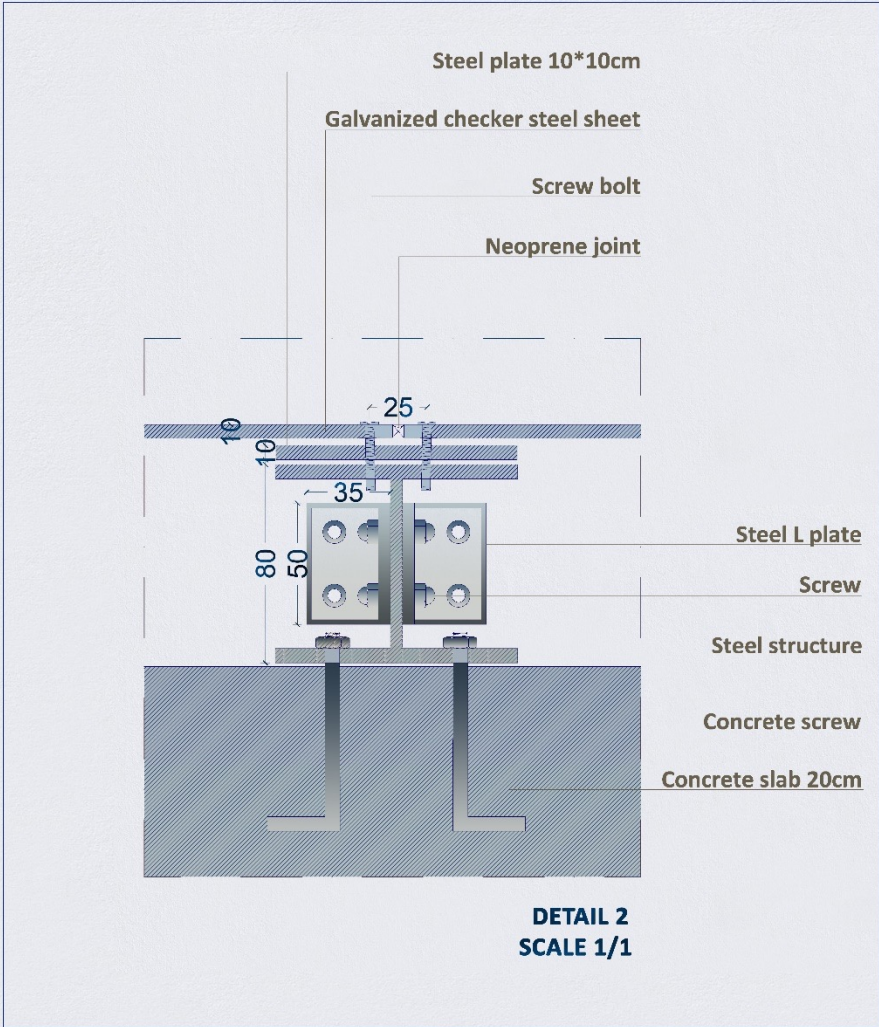

MATERIALS



**REINFORCED
CONCRETE**



GRASS

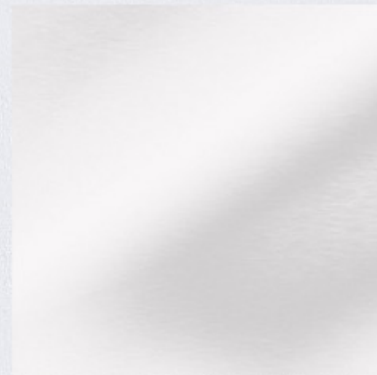

**WHITE
STAINLESS STEEL**

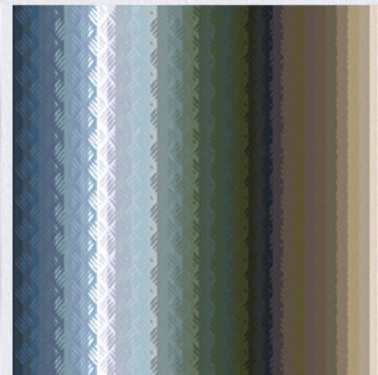

**GALVANIZED
CHEQUER PLATE**



**ABSORBING
PANELS**



SOUL WAVE

