

# Under my own roof

Royal College Of Art

SuperMatter

YUXUAN WANG



# Build The Moon

— Original Apparatus

## Outside ECDC

This is a scene shot outside the ECDC. Workers are carrying wood and entering the ECDC. They are very busy. It's hard to see the construction workers who are having a rest.

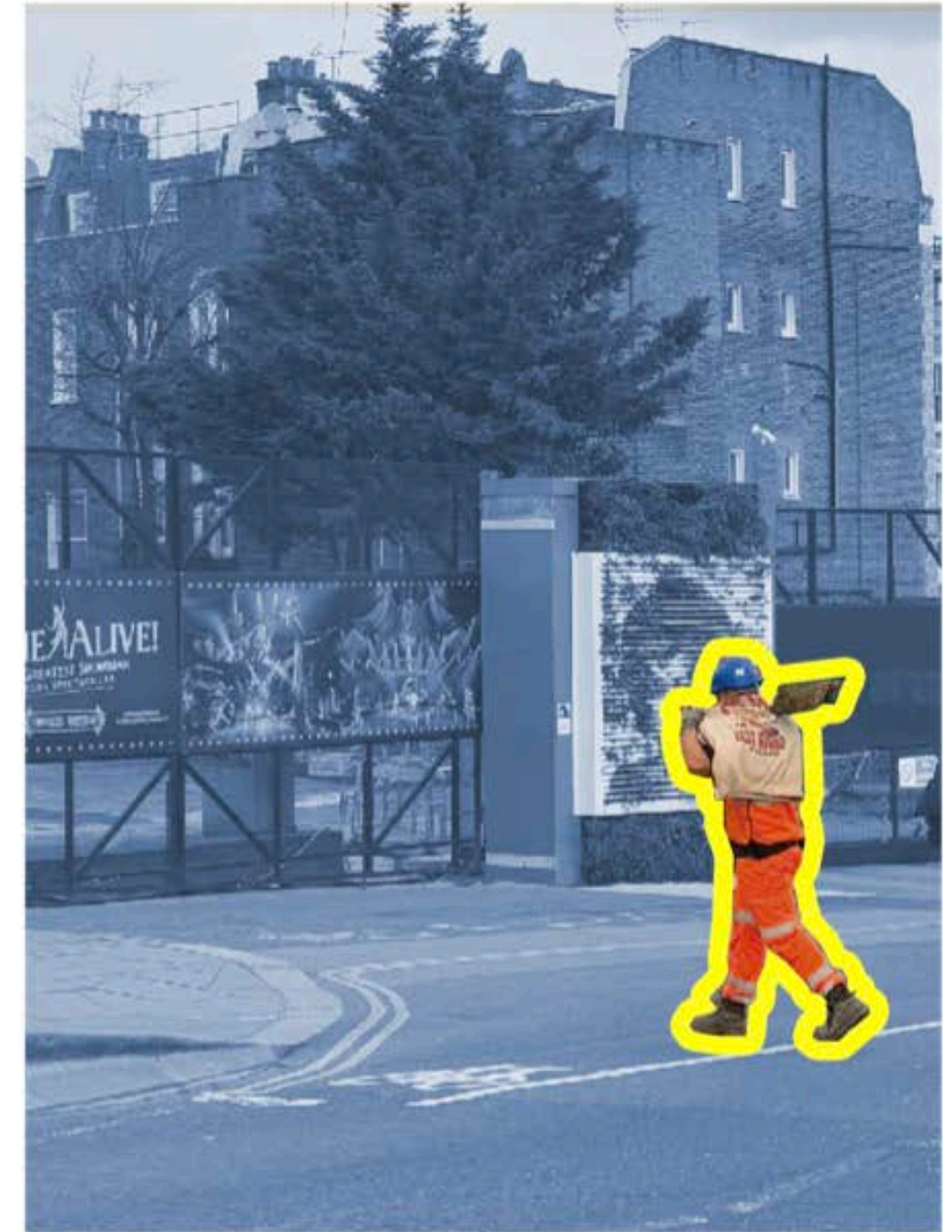

## Inside ECDC

This is a real scene captured at the ECDC construction site. On the left, workers are resting on chairs, while on the right, a makeshift resting area has been created using existing furniture.

On the one hand, this made me realise that the resting space for construction workers urgently needs to be upgraded. On the other hand, it also inspired me to summarise the characteristics of the resting space that workers need:

- There is a shelter - shield from the sun and rain
- Ready-made furniture - easy to move
- not a closed space - facilitate the entry and exit of workers

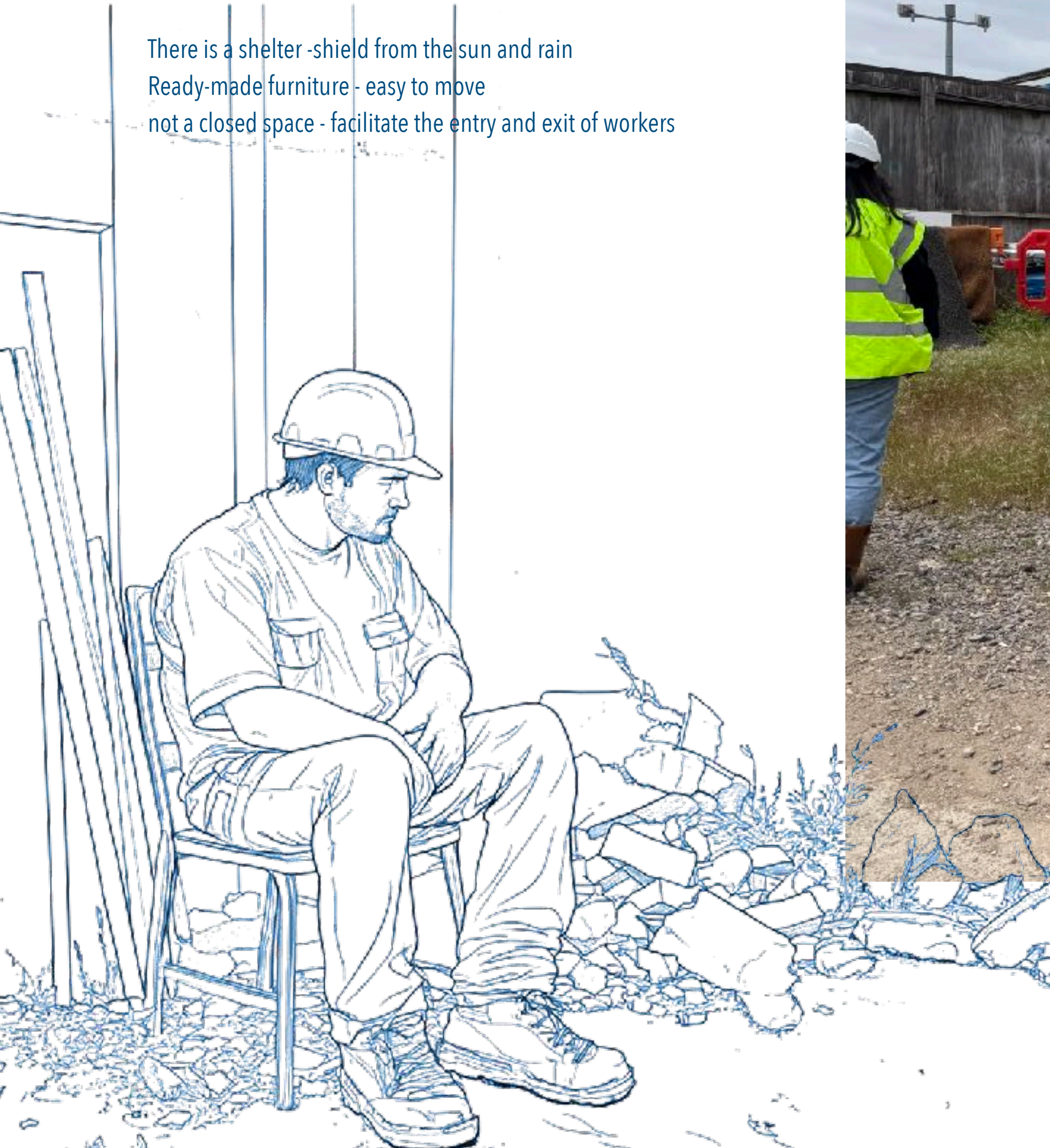

Sleep+Rest

For

Construction Worker



They've been making buildings for others

It's time to make a space for themselves to sleep and rest!

Apparatus: Two conditions





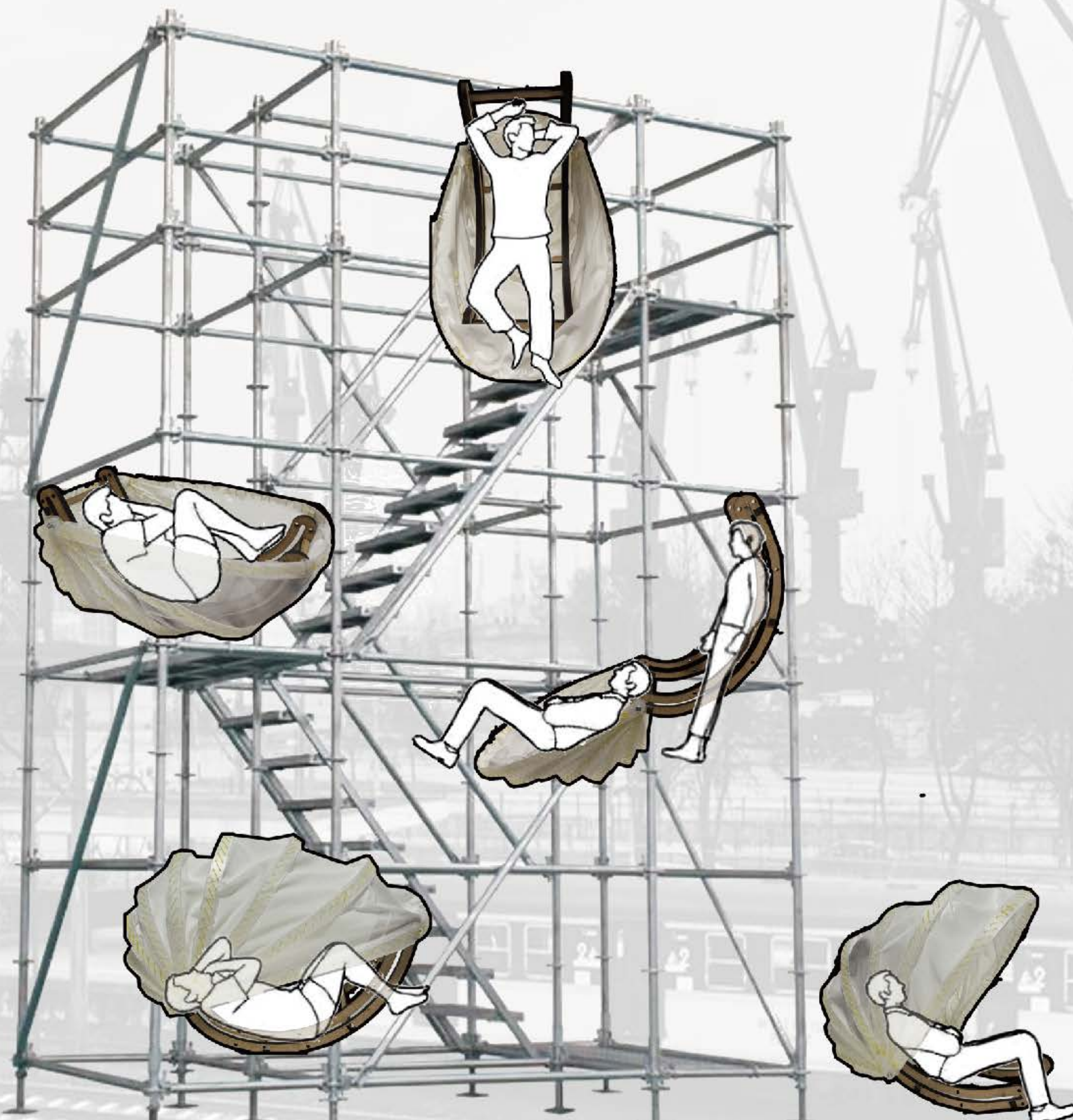
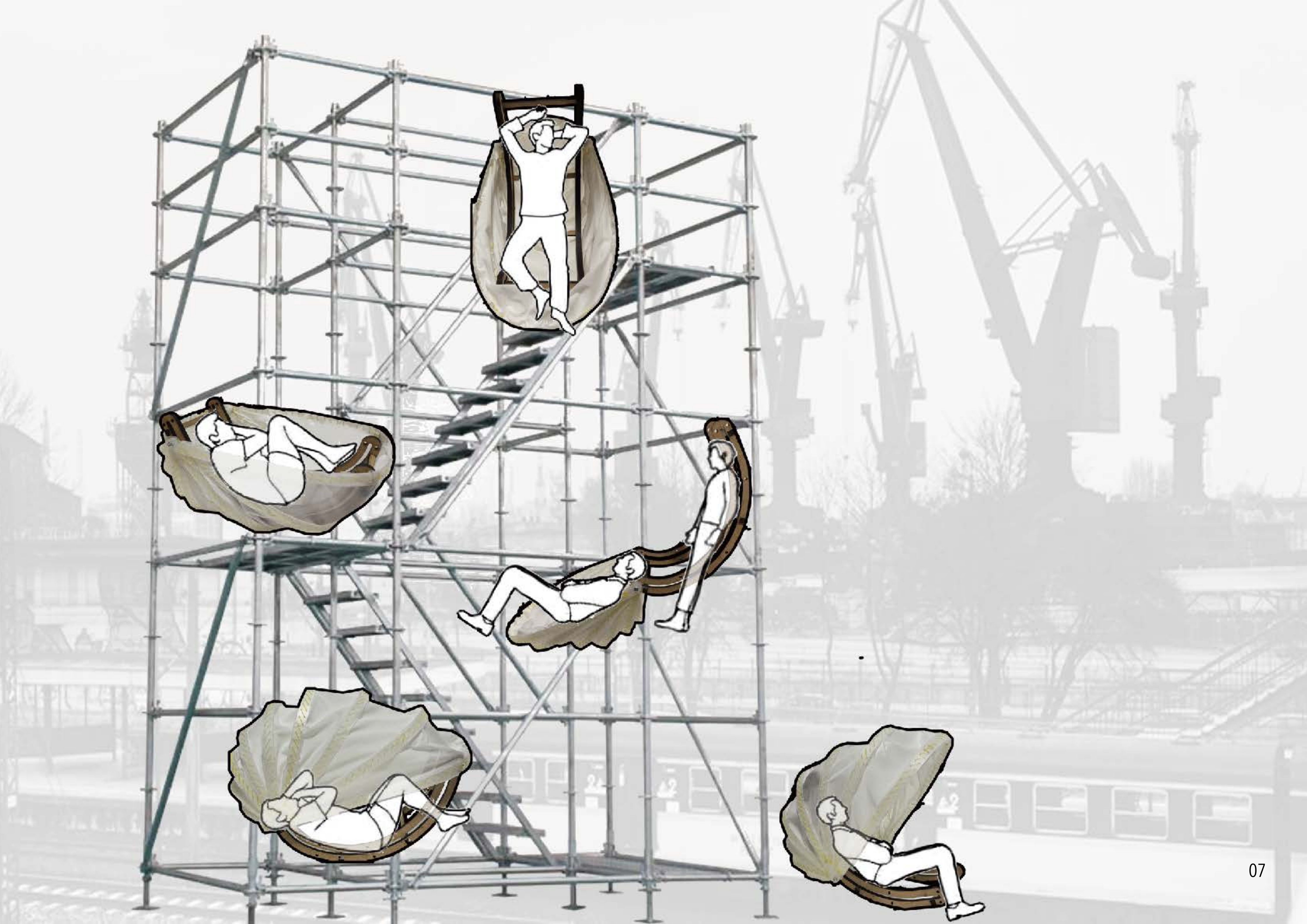

# Design strategy

—— 1:1 Apparatus

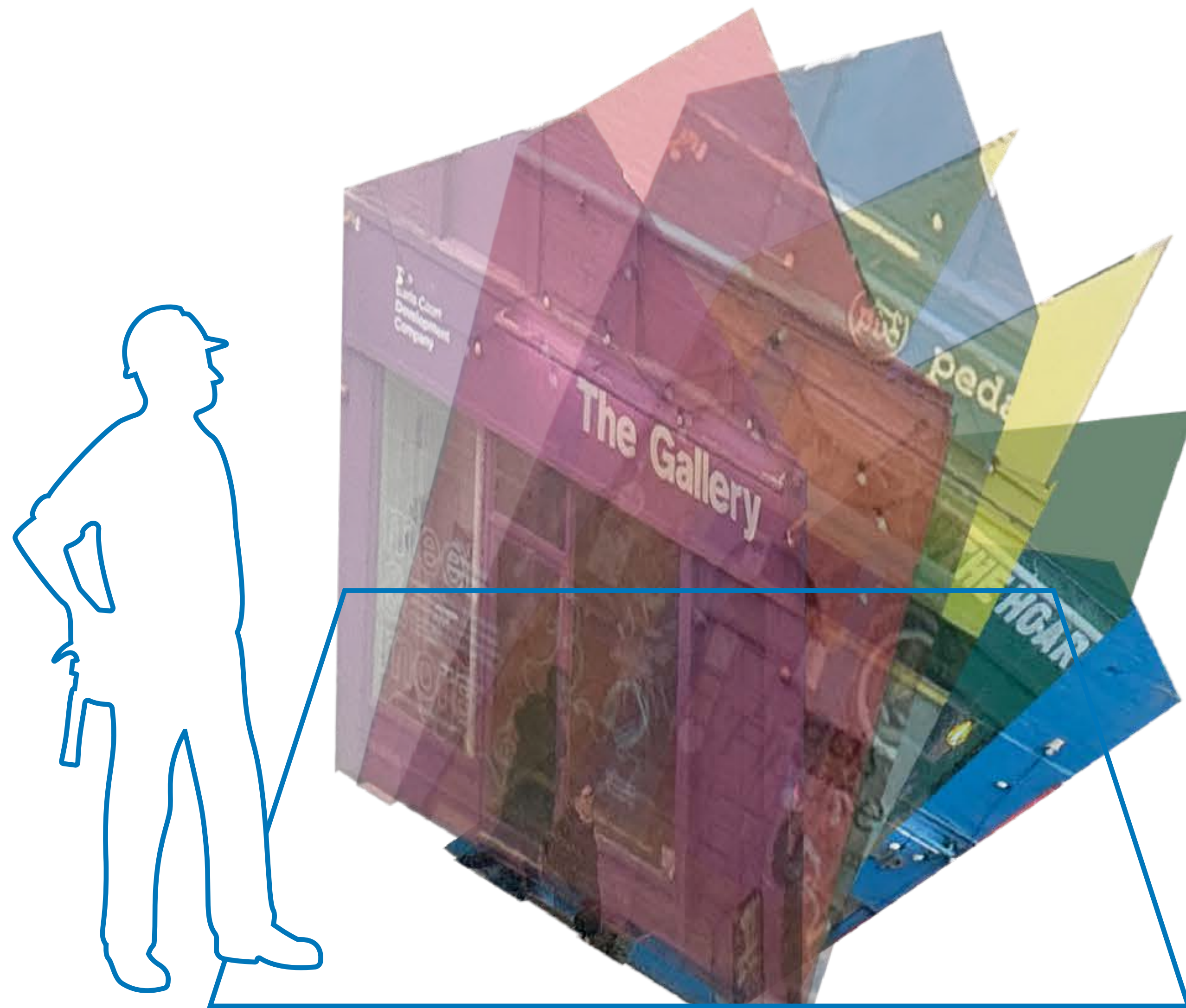

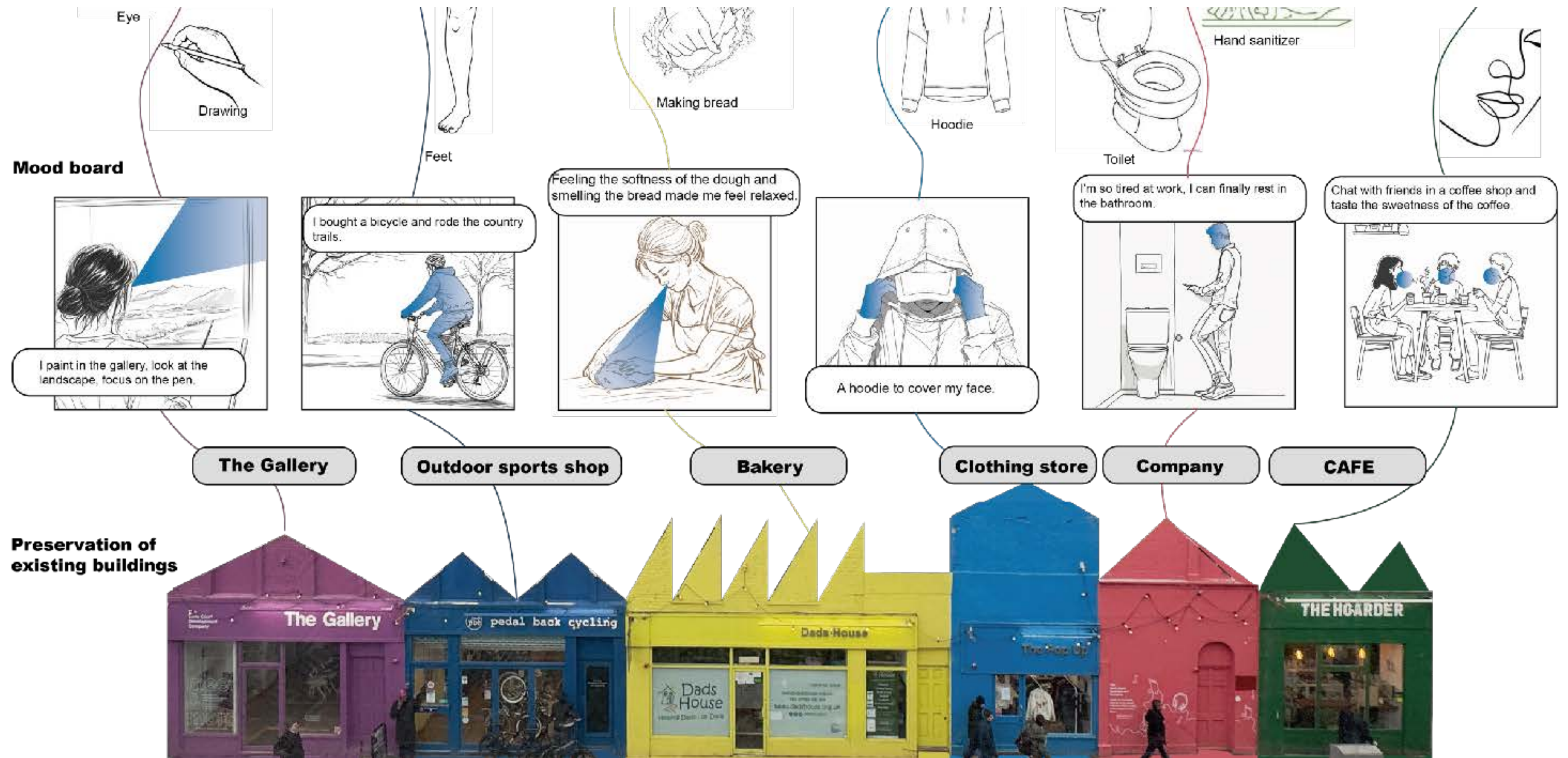

### Shop, mood board and element

People enter leisure shops more for the resting scenario that follows. For example, when a person goes to a gallery, it might be to give research a rest, look into the distance, give their brain a rest and enjoy the view. So I have labelled the body parts, activities and elements within the space that are involved in entering the space, which can be used in the design of the space afterwards.

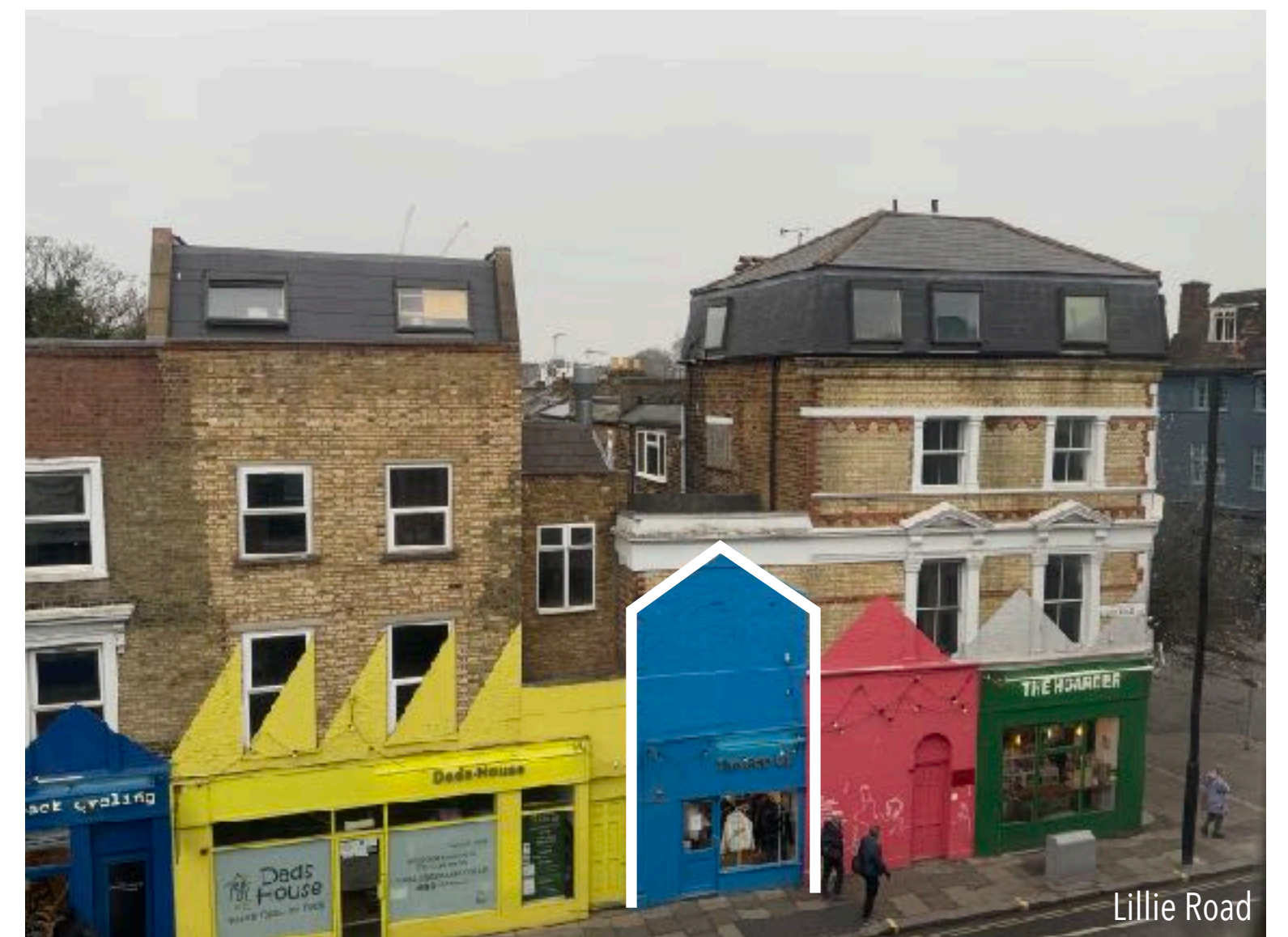
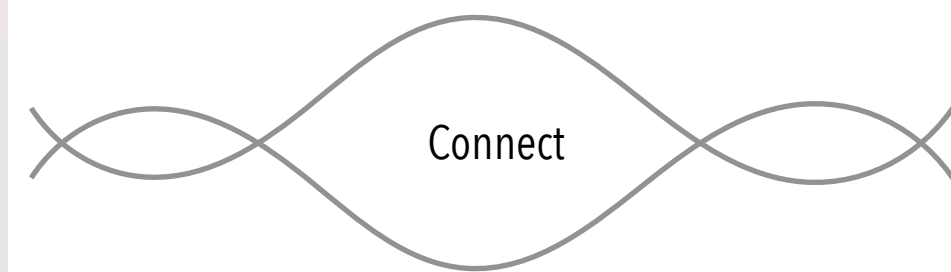

## Apparatus In site

Landing apparatus, suitable for the venue, suitable for the crowd is not a small challenge.  
Due to the unstable nature of the crescent rail in use, a more stable ergonomic base will be replaced for safety reasons.  
At the same time, the roof on Lillie road is very attractive to me, so the structure of the shelter part is changed into the shape of the roof, which will be more closely related to the site.

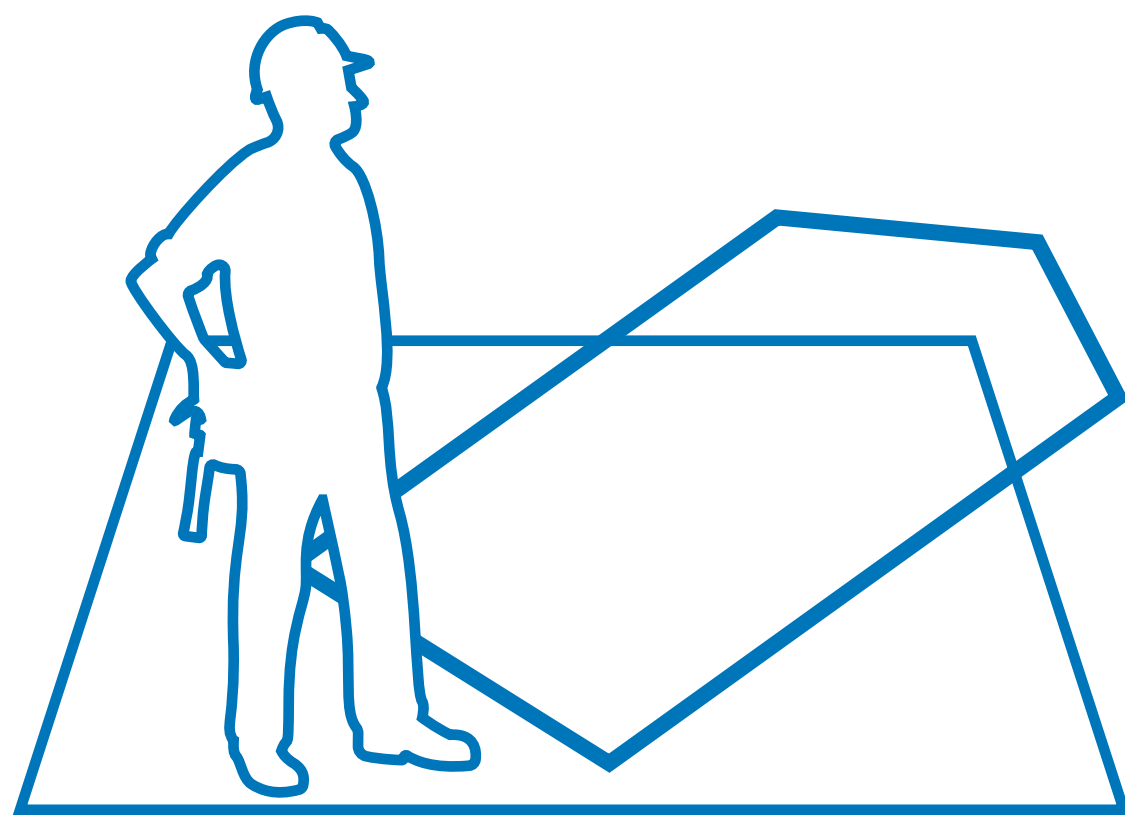

Fold

Expand

Open it , open rest

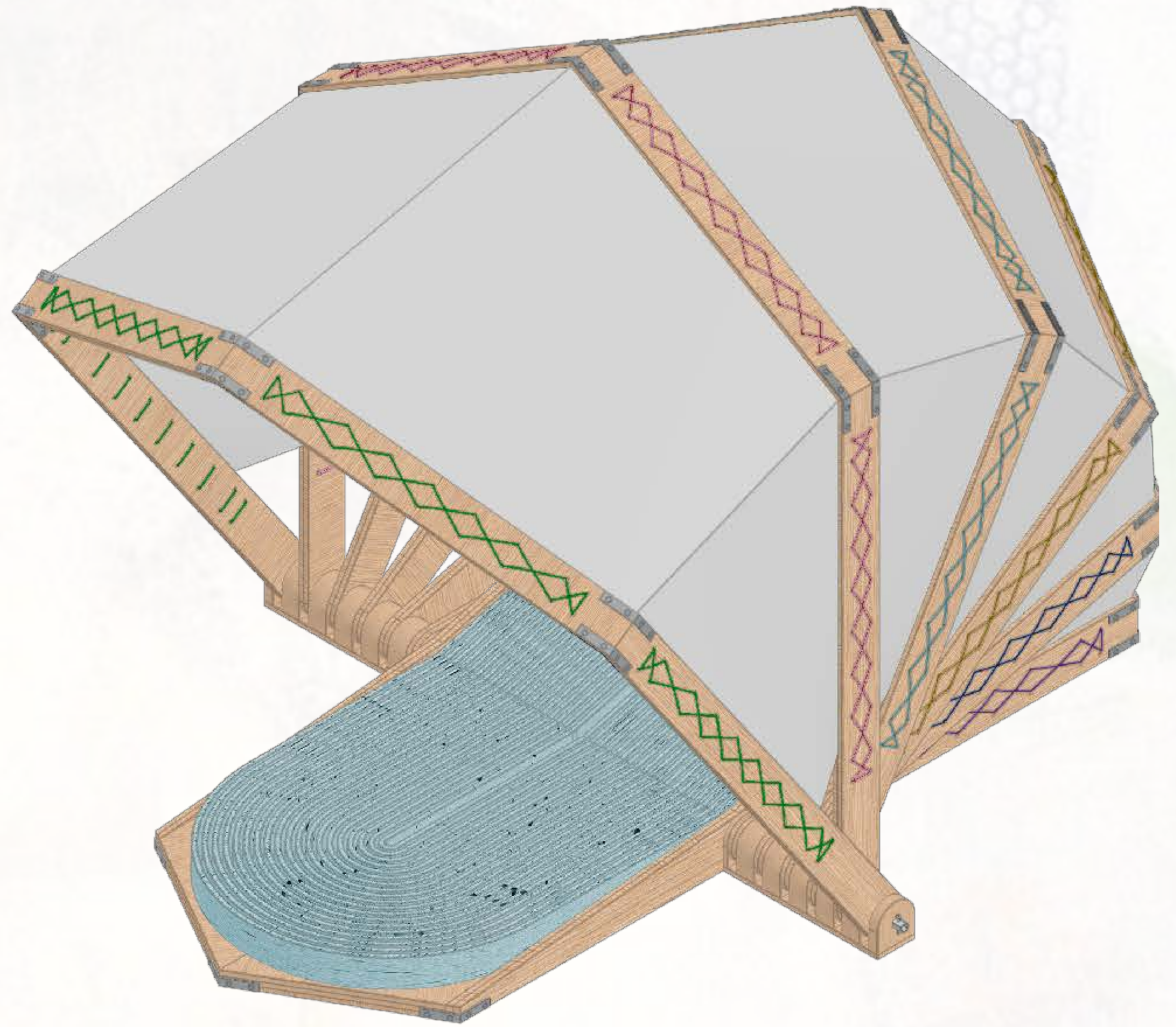
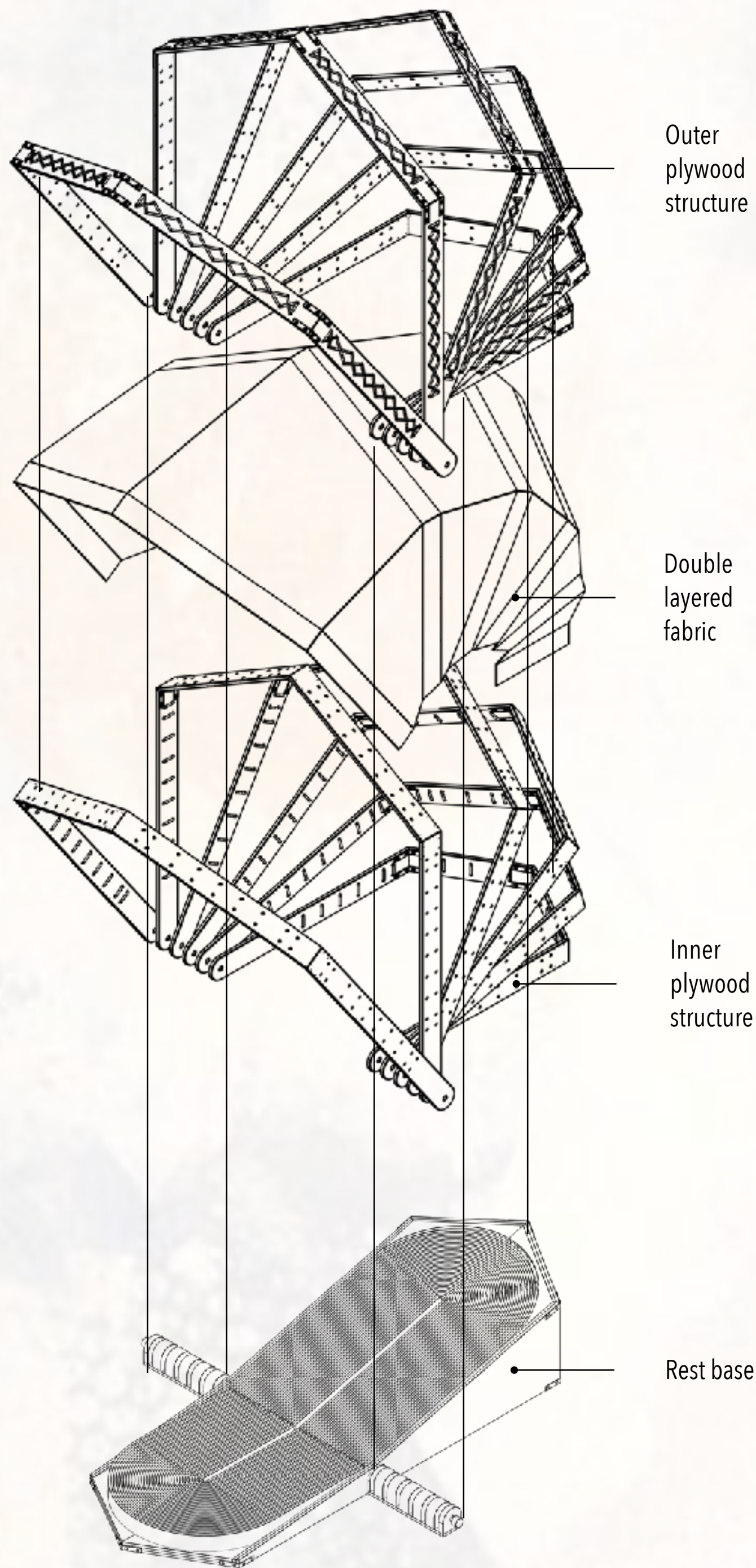

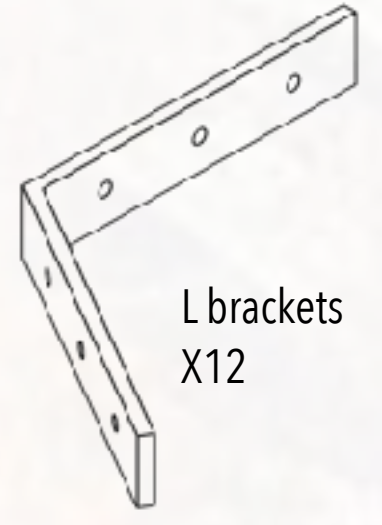
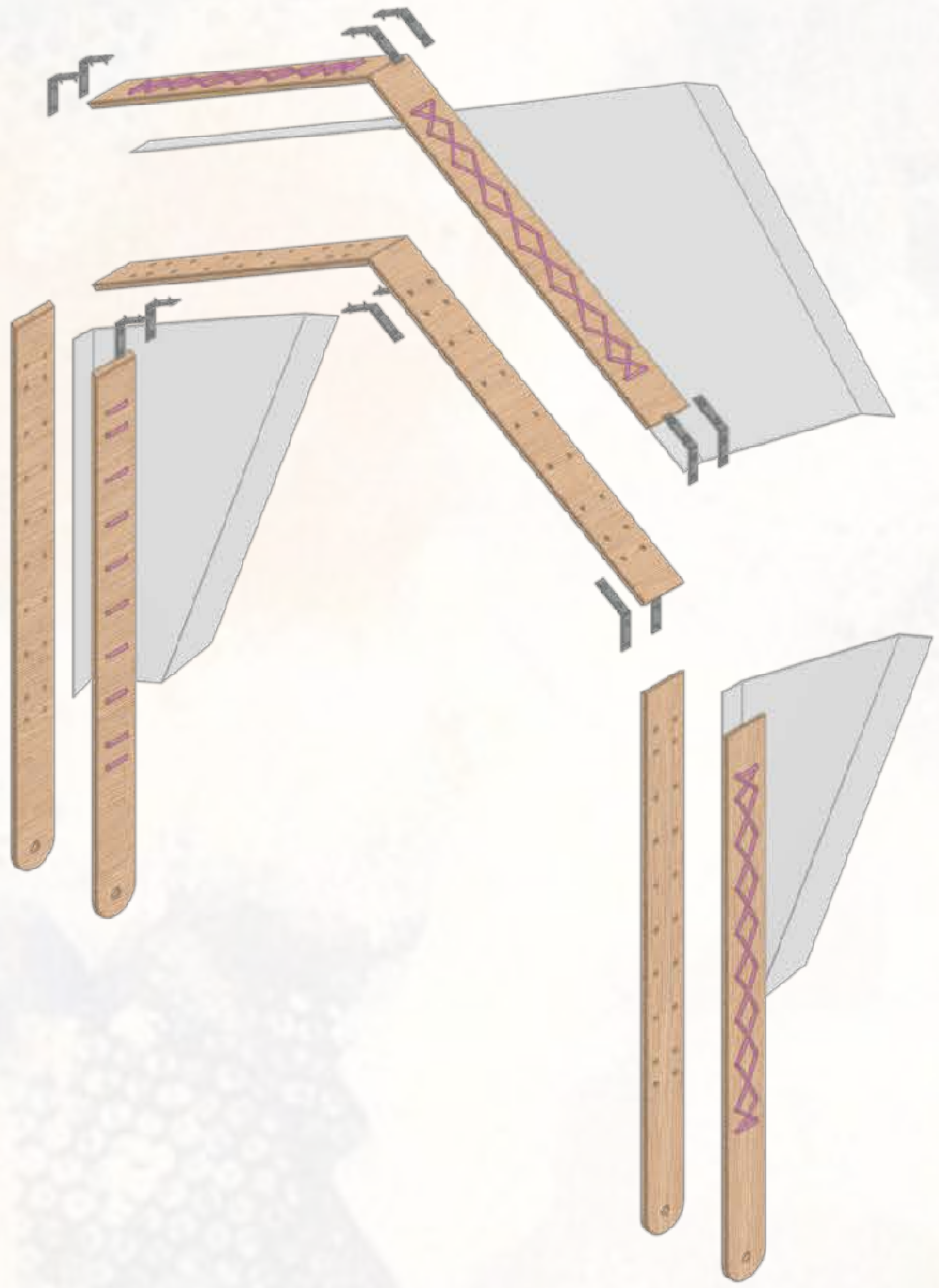

L brackets  
X12

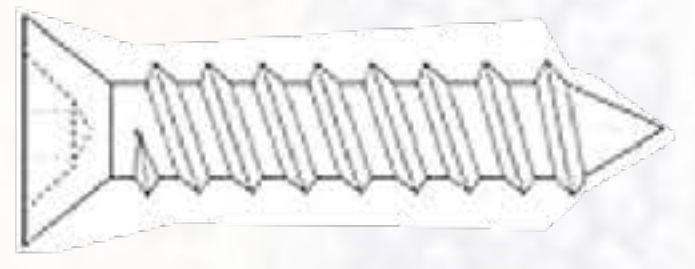

Woodscrew  
X48

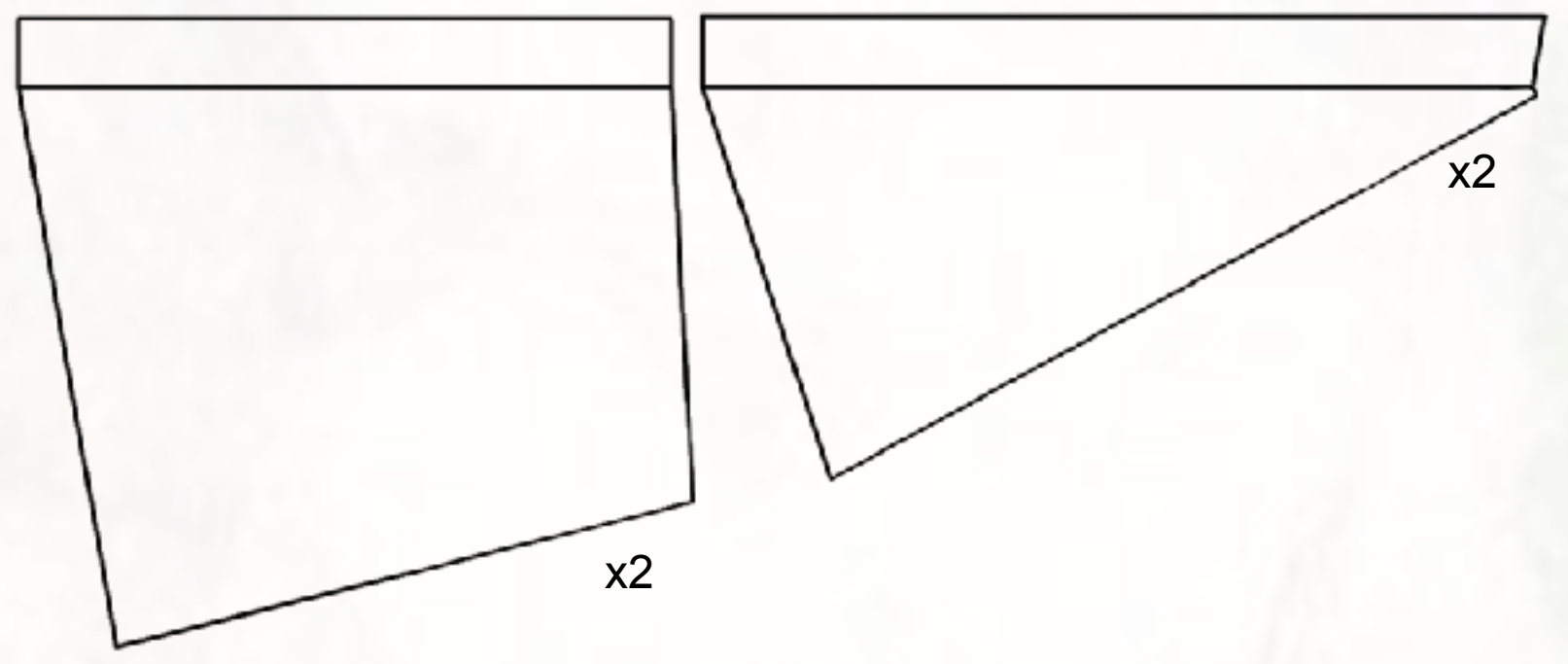

Woven Polypropylene pp bag  
X4

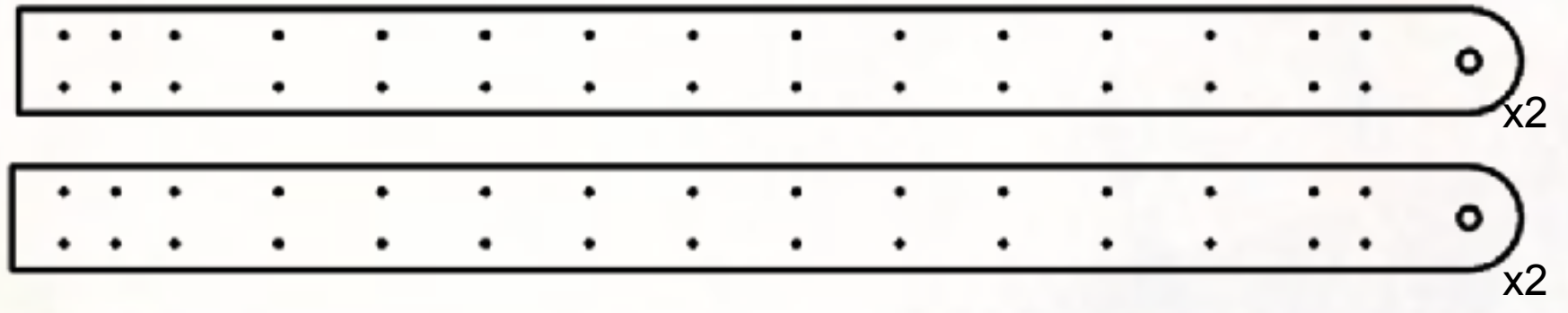
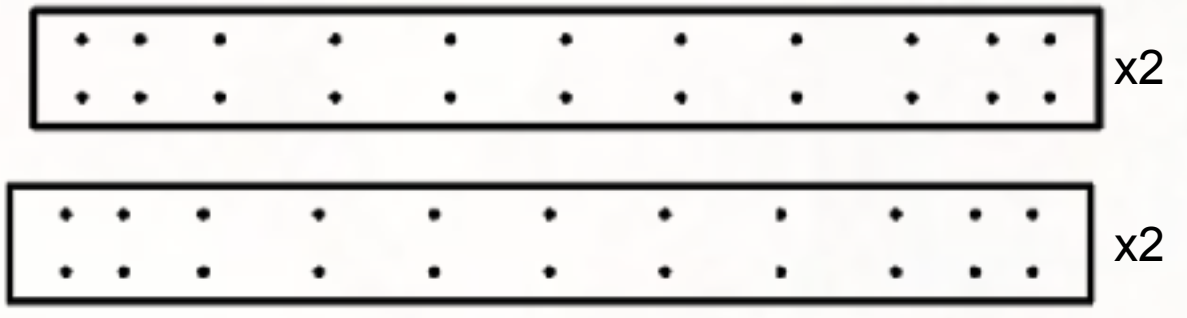

8 Birch Plywood frame  
X8



# Material & Making process

---

## 1:1 Apparatus

ECDC Site



The Gore London - Starhotels Collezione



Super MATTER

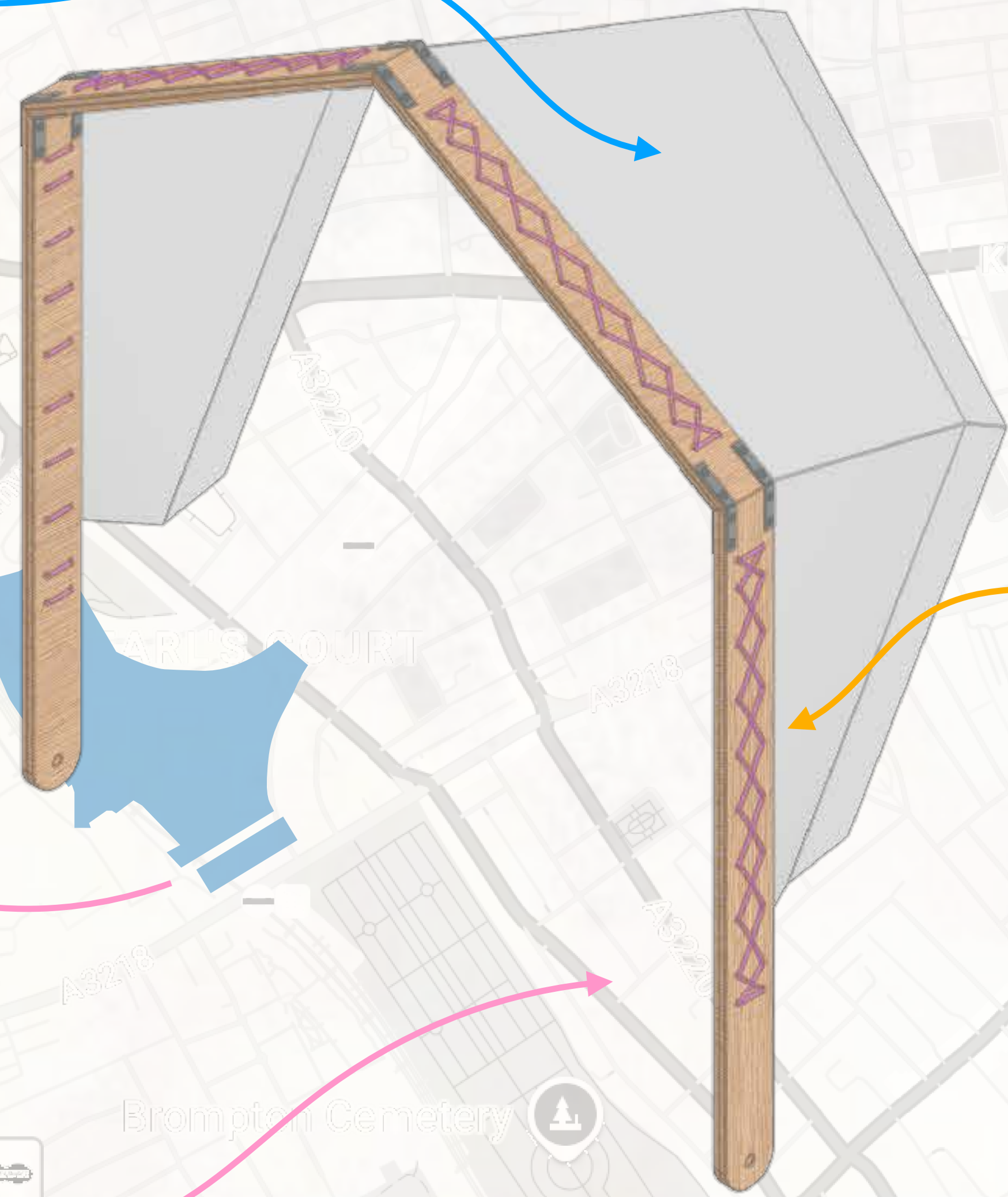

Lillie Road





Original building woven bags



Separate



Washing Dirt and dust on the surface



Print paper sample

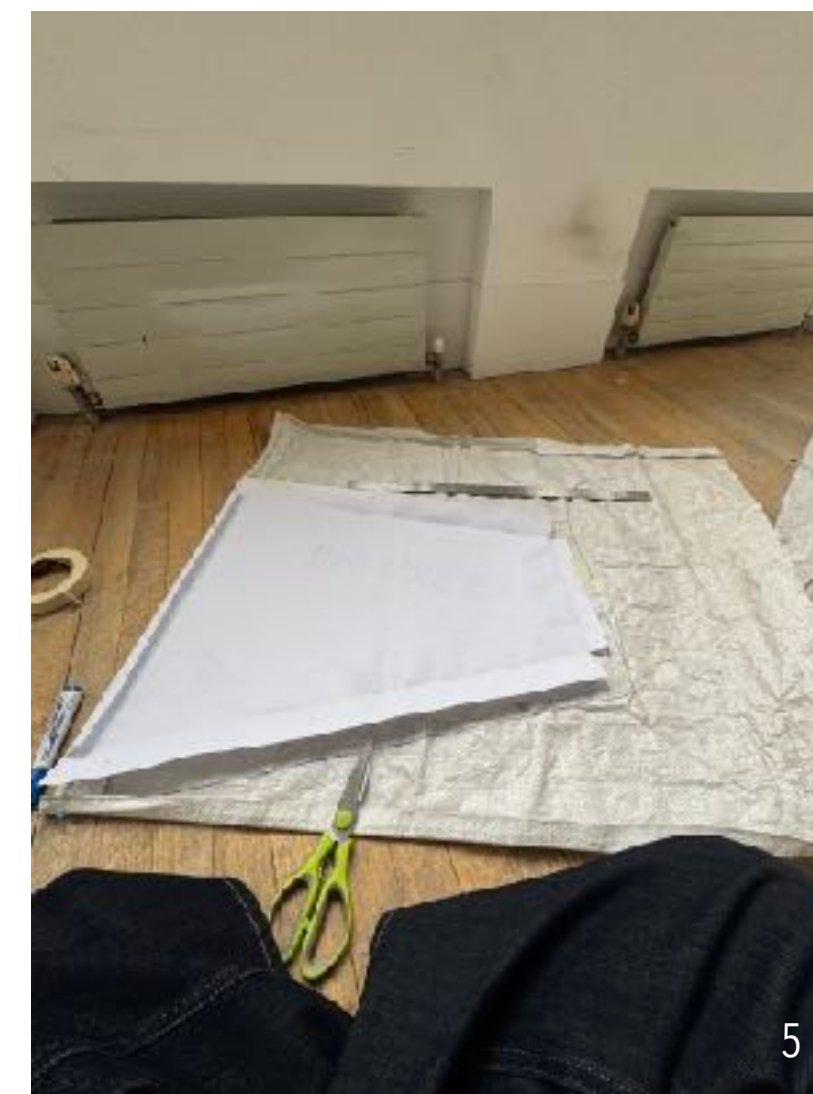

cut it to the required size



Stitch

## Trace

When I unpacked the original bag, I discovered traces of recycled materials, including **soil and sand**, **yellow rust stains**, **blue marker pen marks**, and **drag marks**...

I believe this is the charm of recycled materials, and I will do my best to preserve these traces in the future.

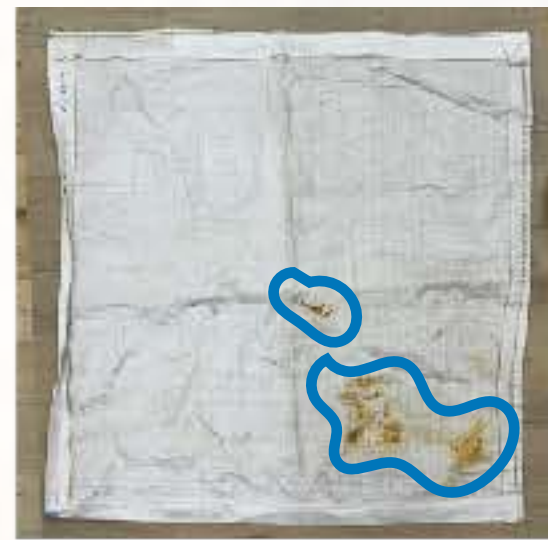

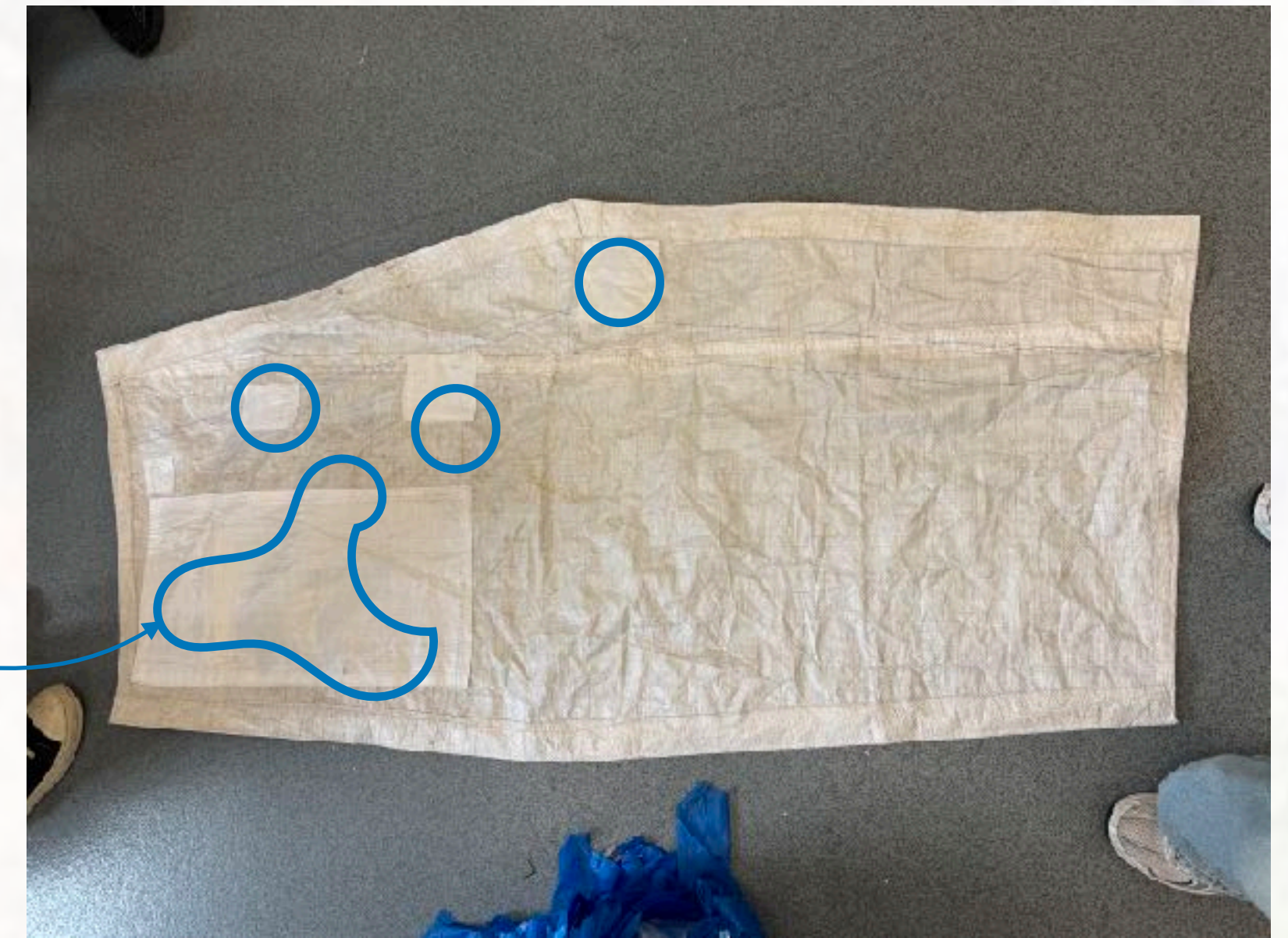
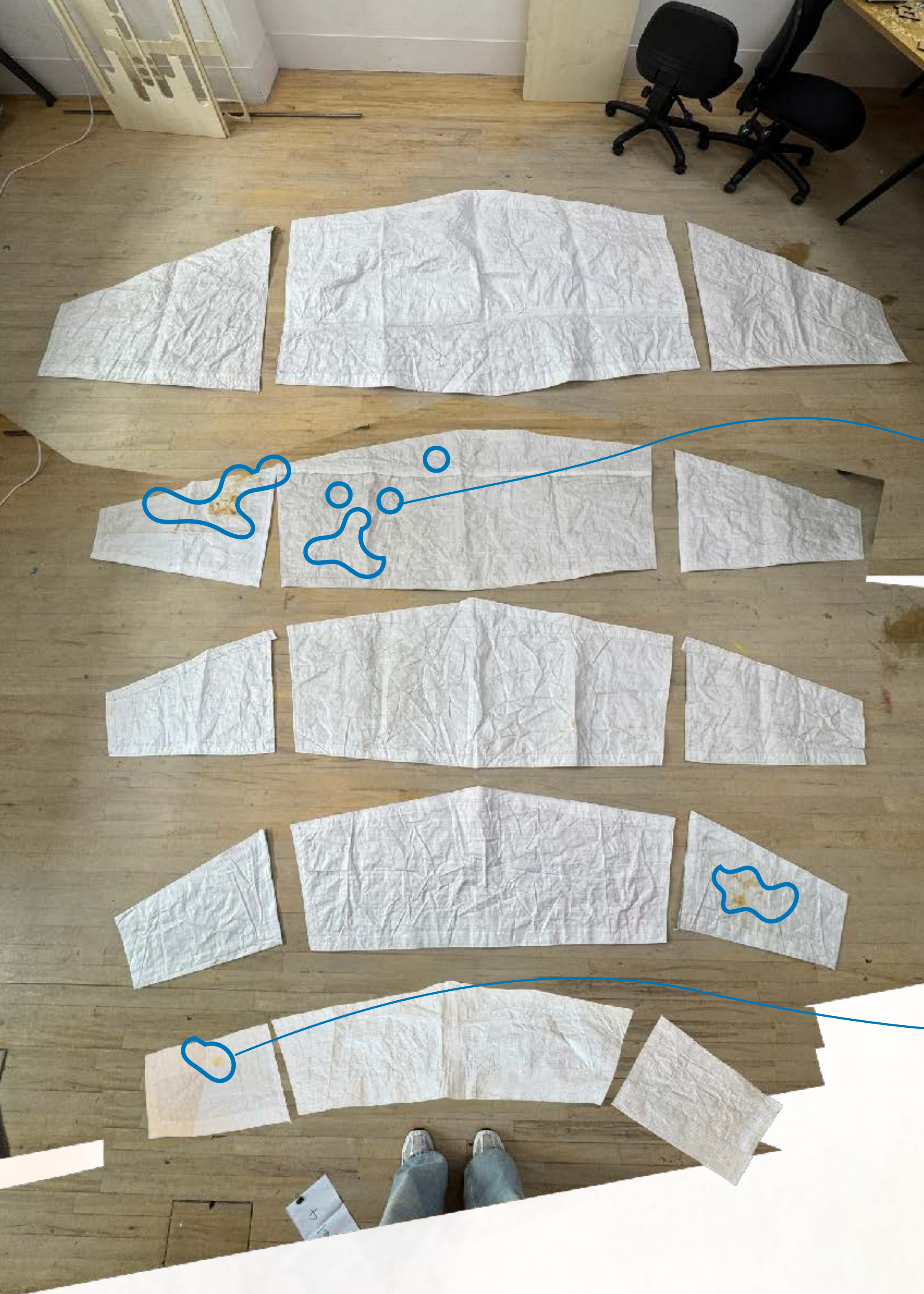

Some bags had holes in them, so in order to preserve the traces of use and ensure the durability of the material, I cut out unused pieces and sewed them onto the back of the holes.

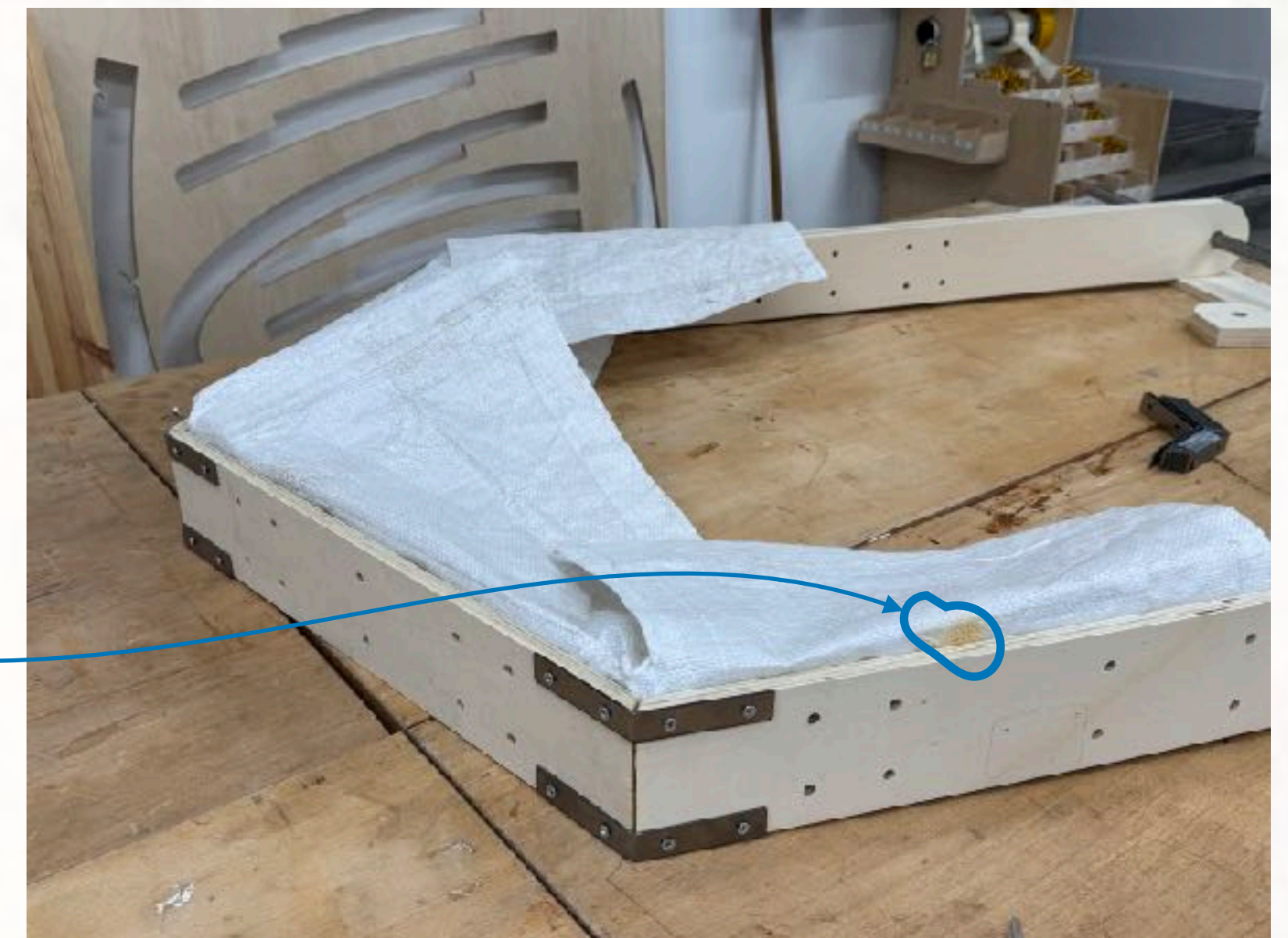

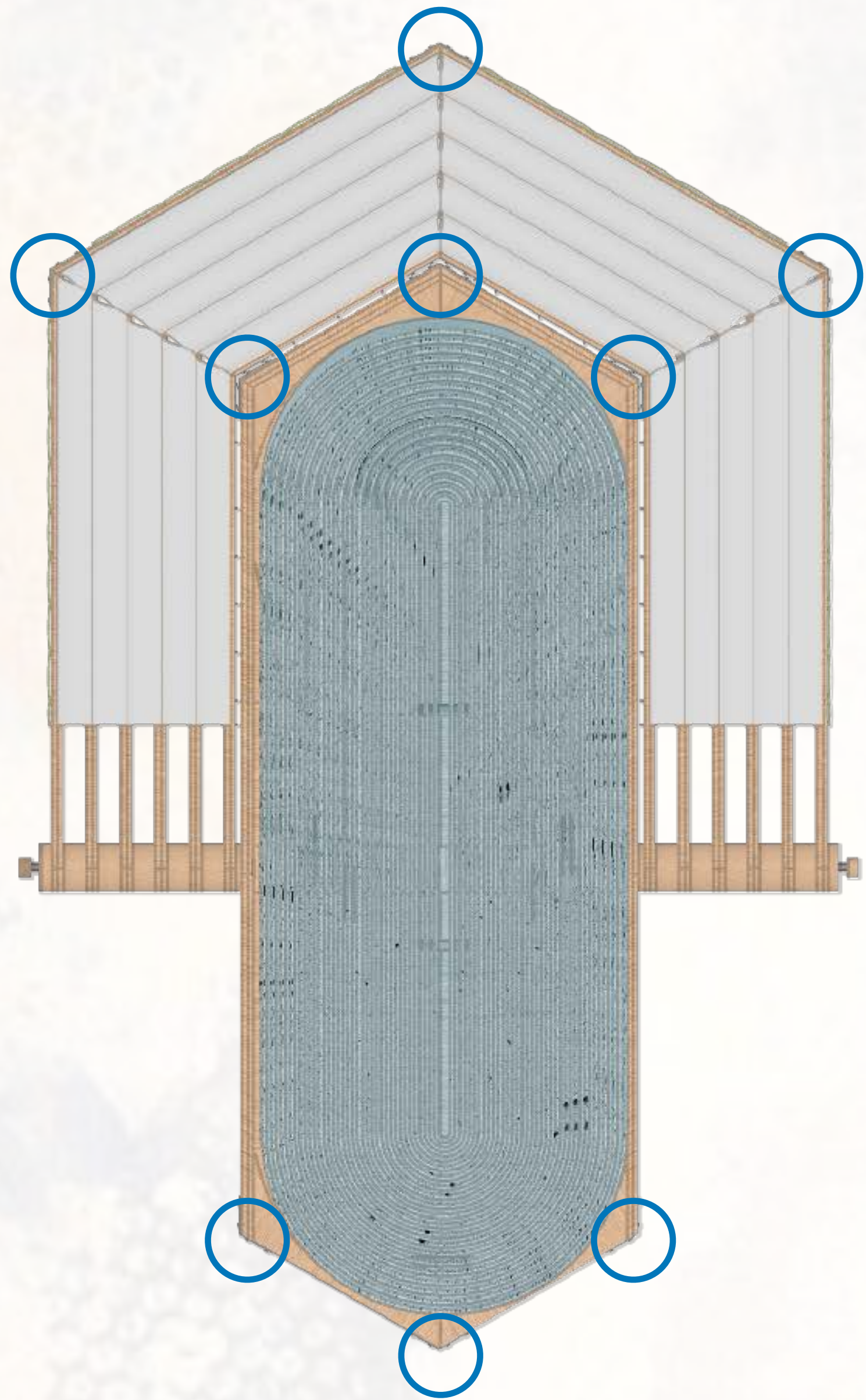

Play with 120 degree

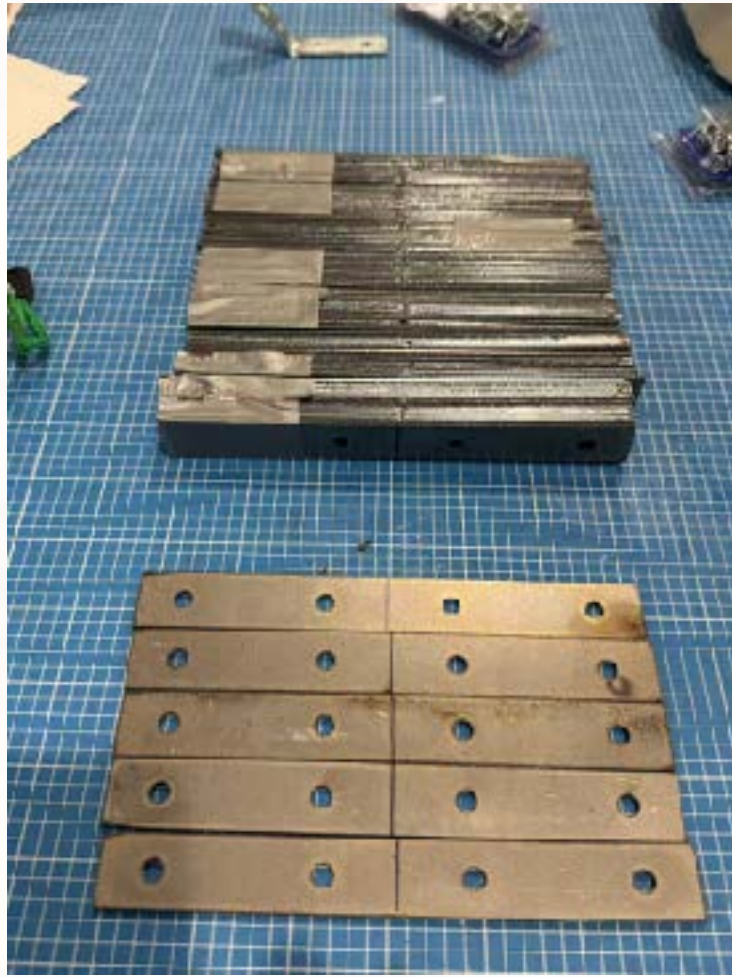
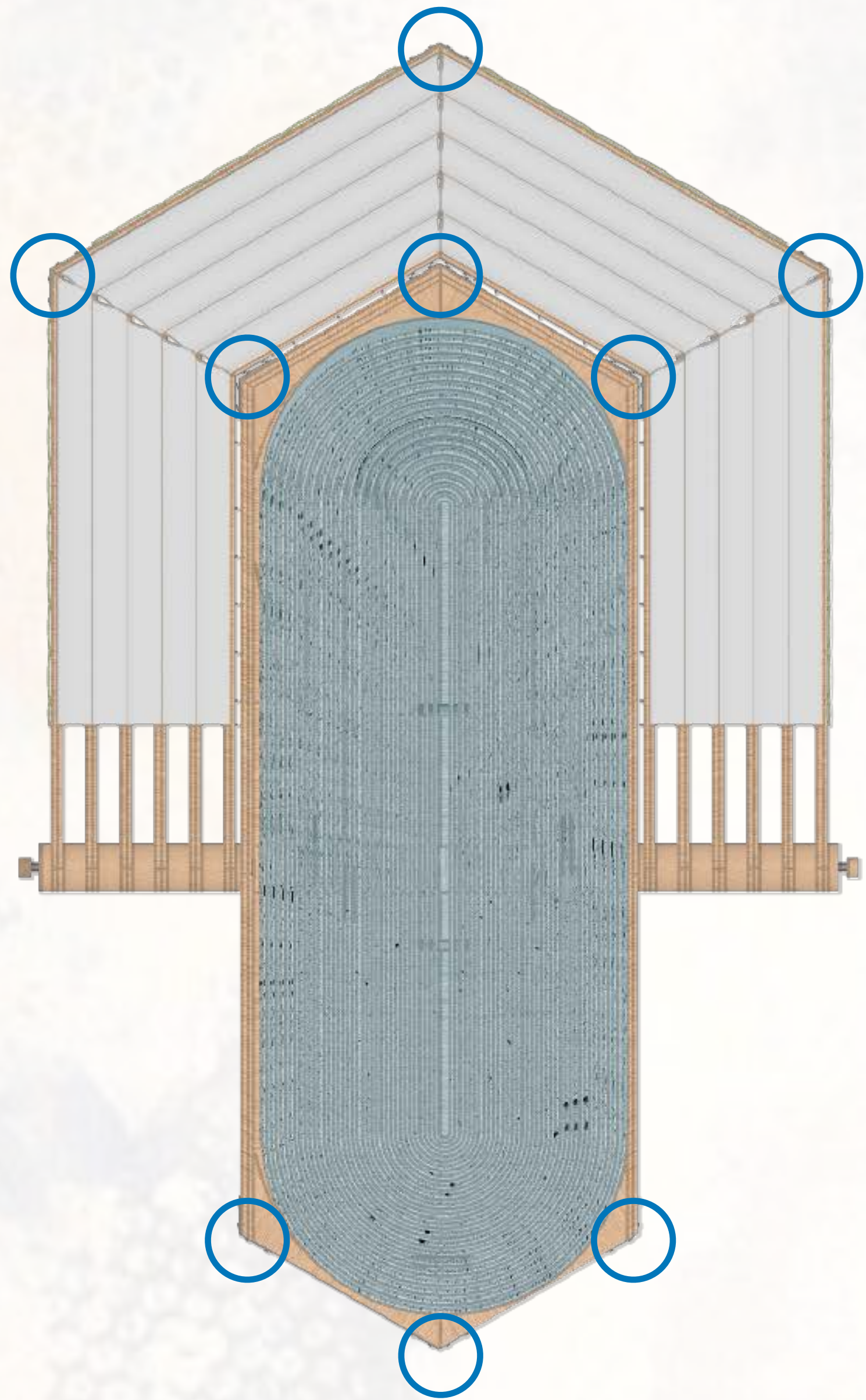

Play with 120 degree

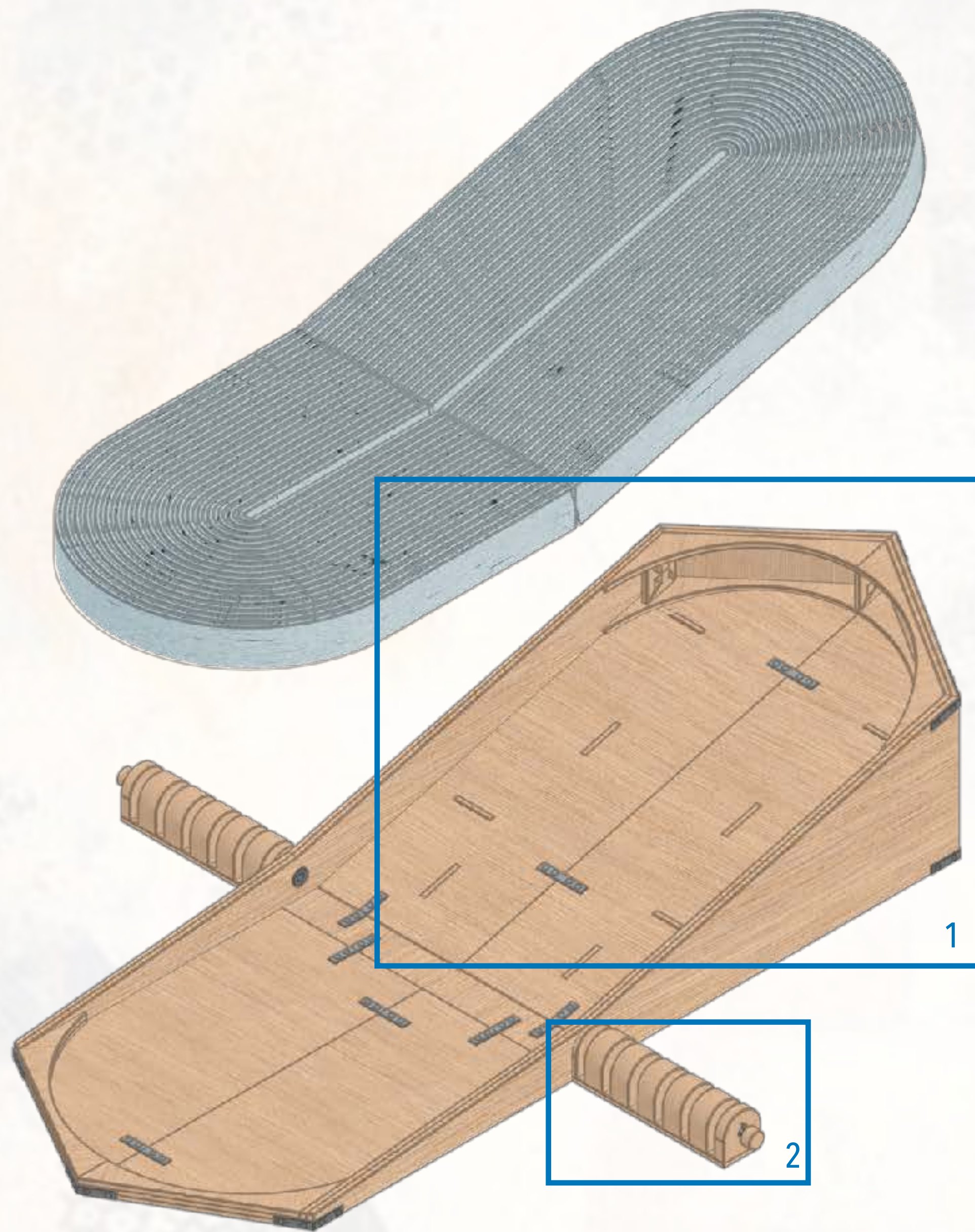

**Mortise and tenon joint structure**

Some mortise and tenon structures have been added inside. Compared with metal connectors, it is more secure and easier to disassemble.

1



**Eye bolt**

At the place where the two parts of the shaft are connected, the interface is sealed by a connecting piece, which is conducive to handling and moving.

2

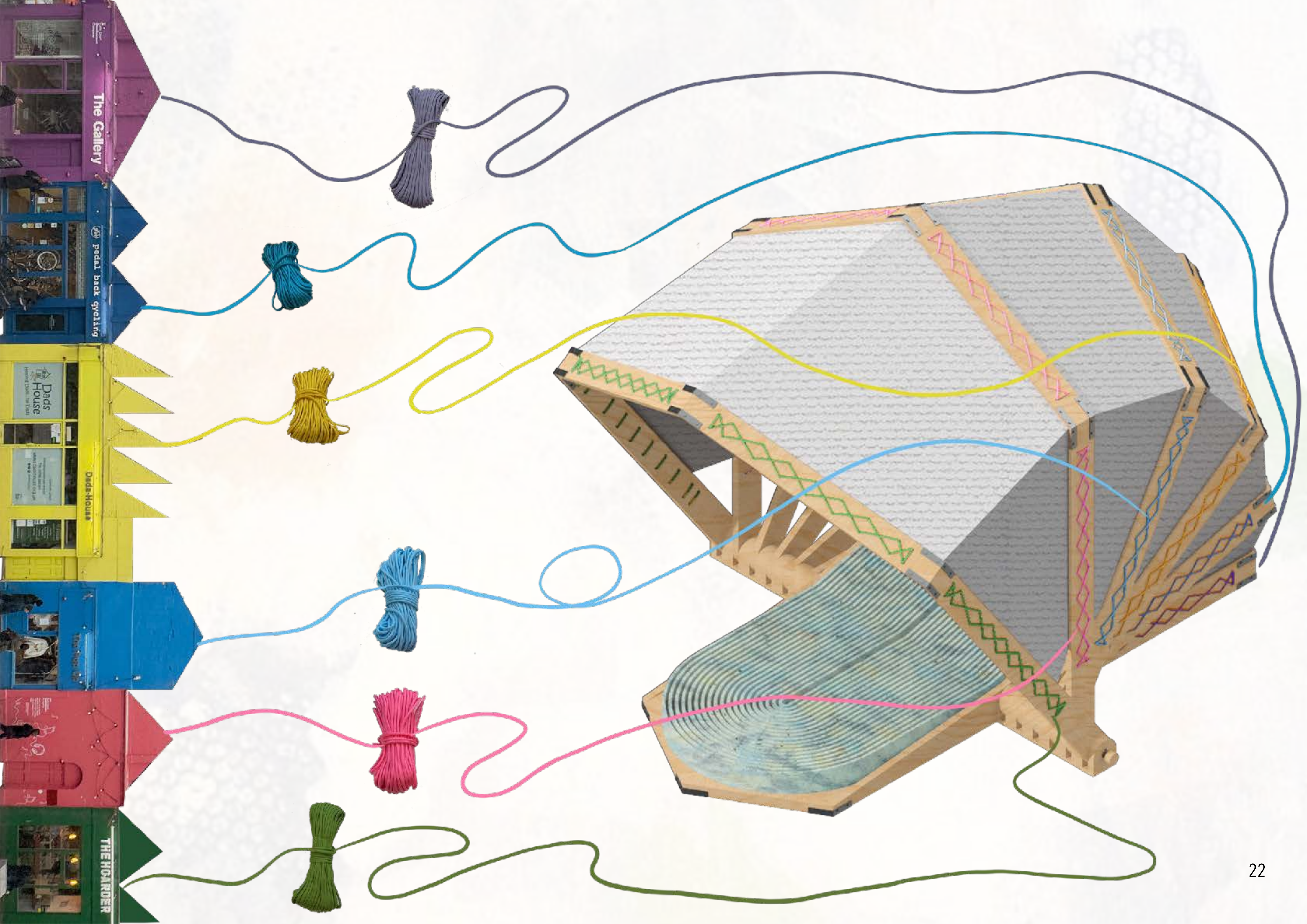



Is this a bed where one can rest?



Let's try to expand it!



So cool! Under my own roof, no one can disturb me!

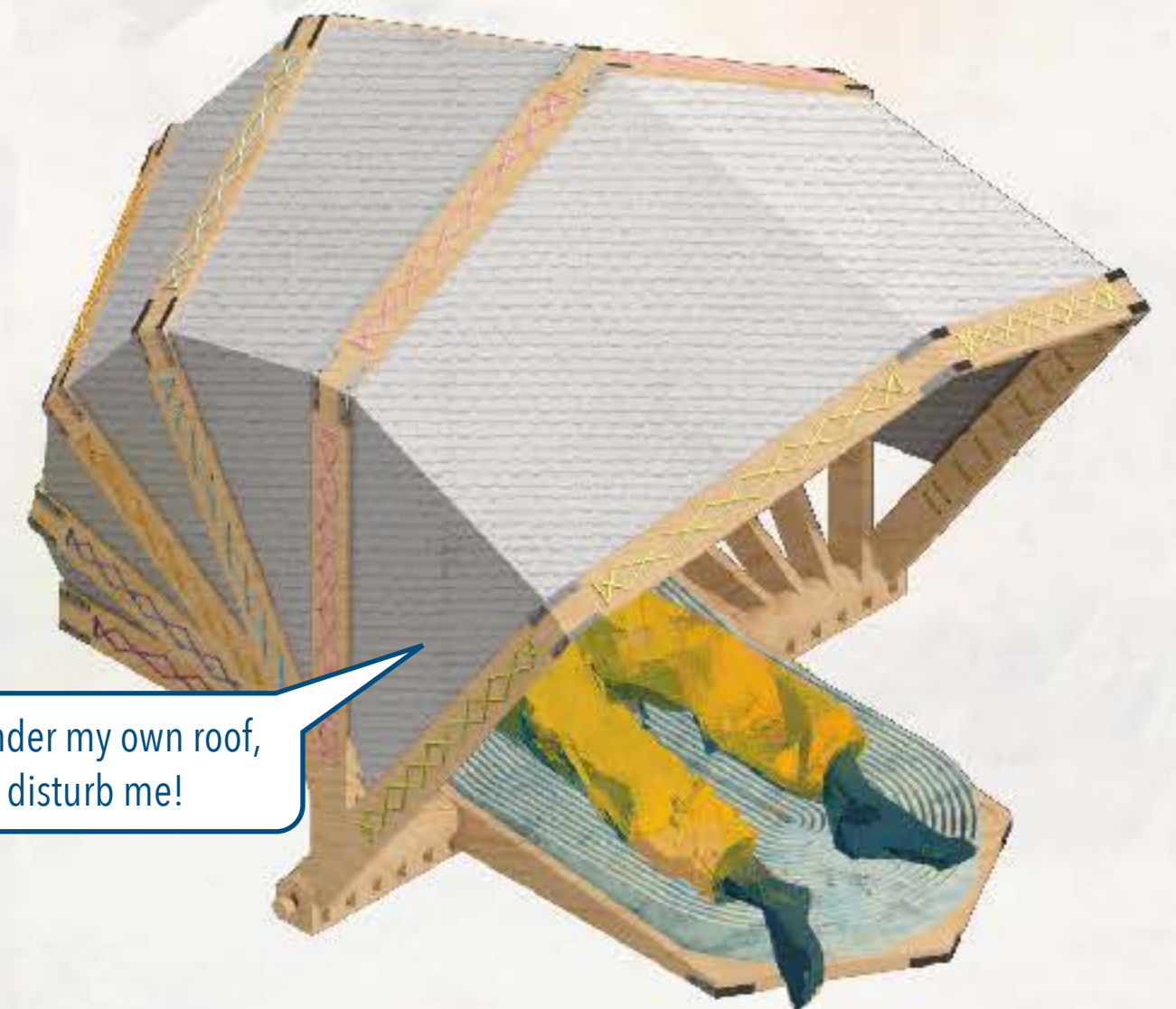



# Under my own roof

---

1:1 Apparatus



Under My Own Roof at final show site





Unternehmensname  
Büro: 11, 10000 Berlin  
Telefon: 030 12345678  
E-Mail: info@firma.de  
www.firma.de





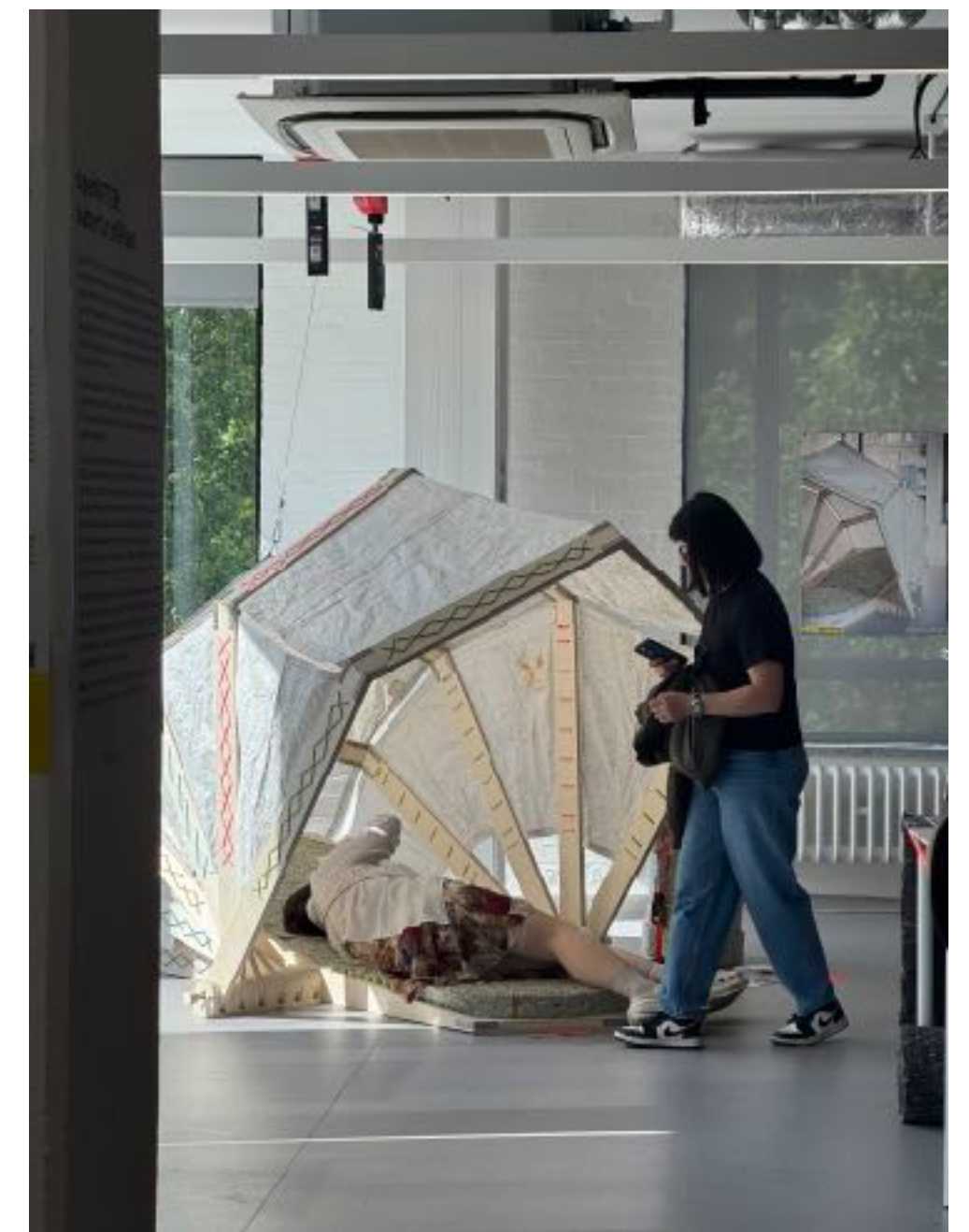

Visitors are experiencing



Under My Own Roof at Lillie Road Gallery





Detail

# Sharing Rest

Spatial Design of Lillie road



Short break  
 Long break



## Population analysis and timeline

I researched the crowds and found that the shops above Lillie road mainly serve the general public but at the same time there are two types of crowds because of the large number of workers on the earl's court site.

I marked the timeline of the two groups of people taking breaks and found that some of the times overlapped and some of the times staggered. Perhaps in the future we can design flexible spaces to serve both groups.





### Axis horizontal

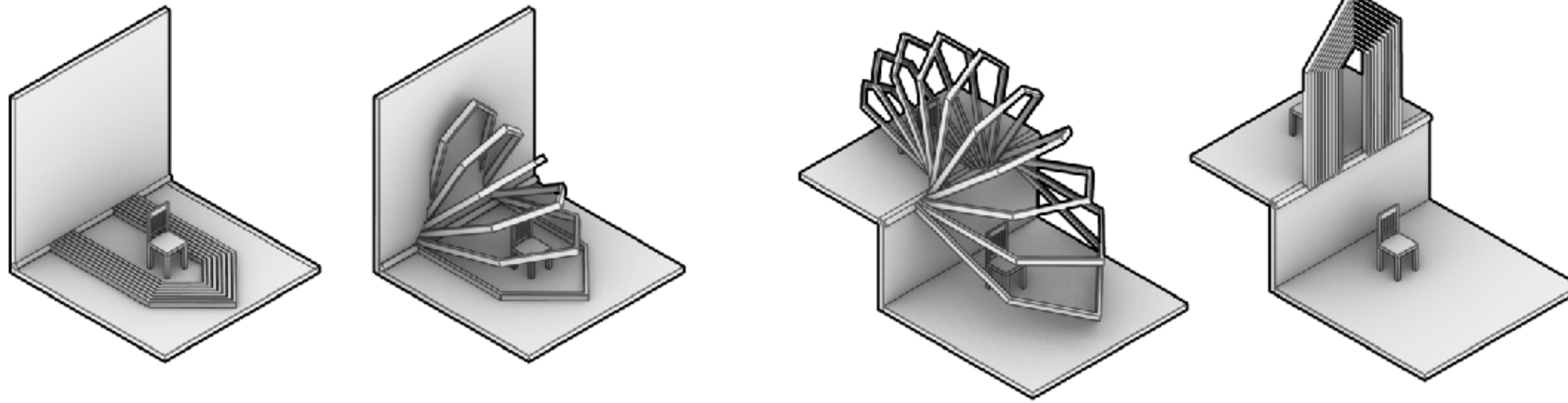

### Vertical axis opens at different angles

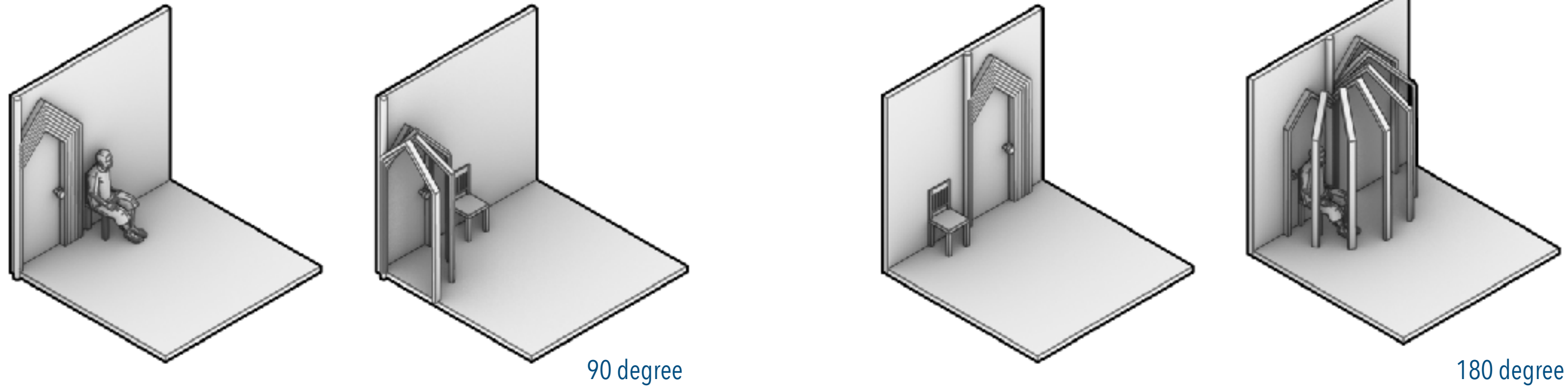

### Morphological exploration

The scale can be changed in the future, the large scale is a wall or atrium space, and the small scale can be the size of a single bed.

### Spatial connection

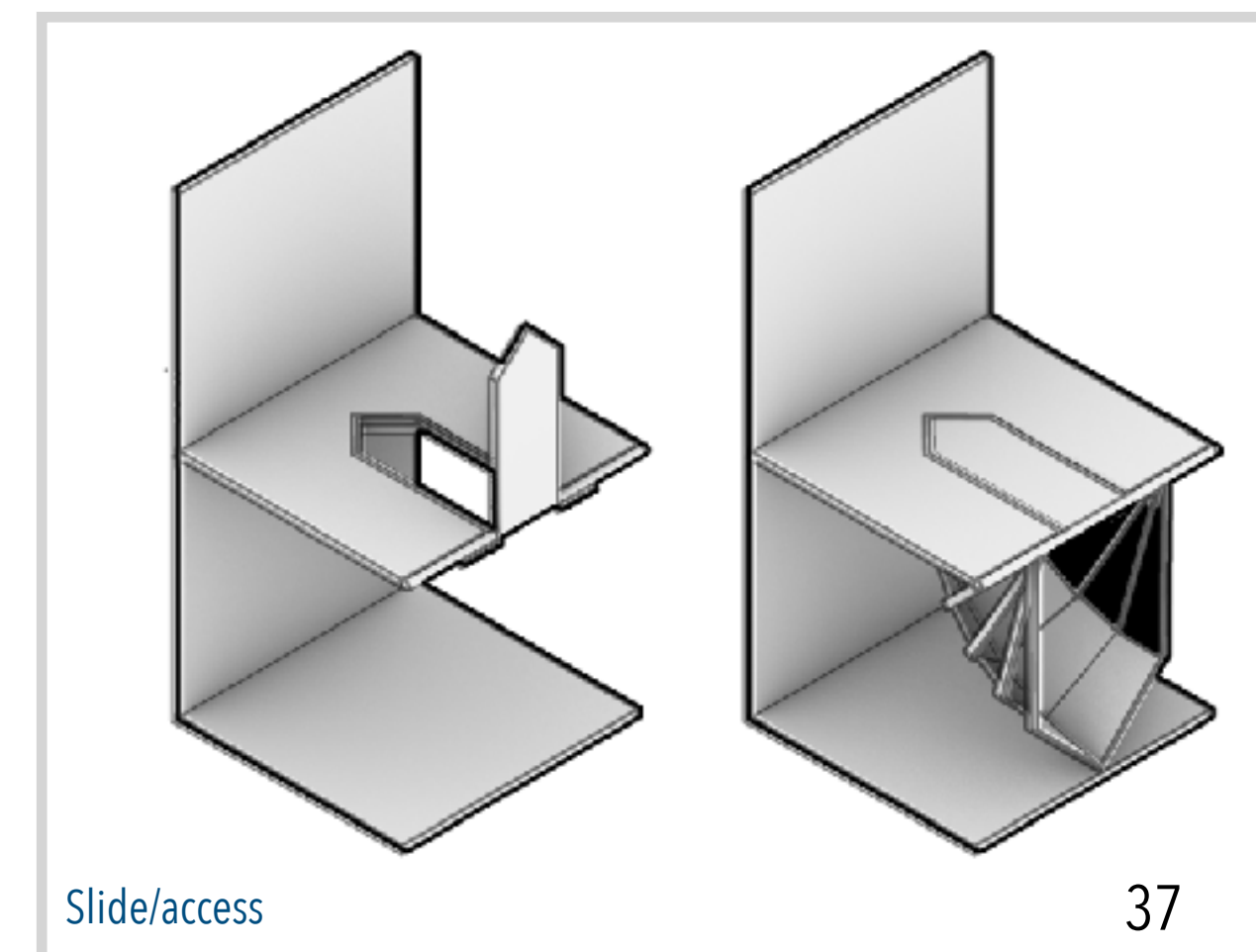
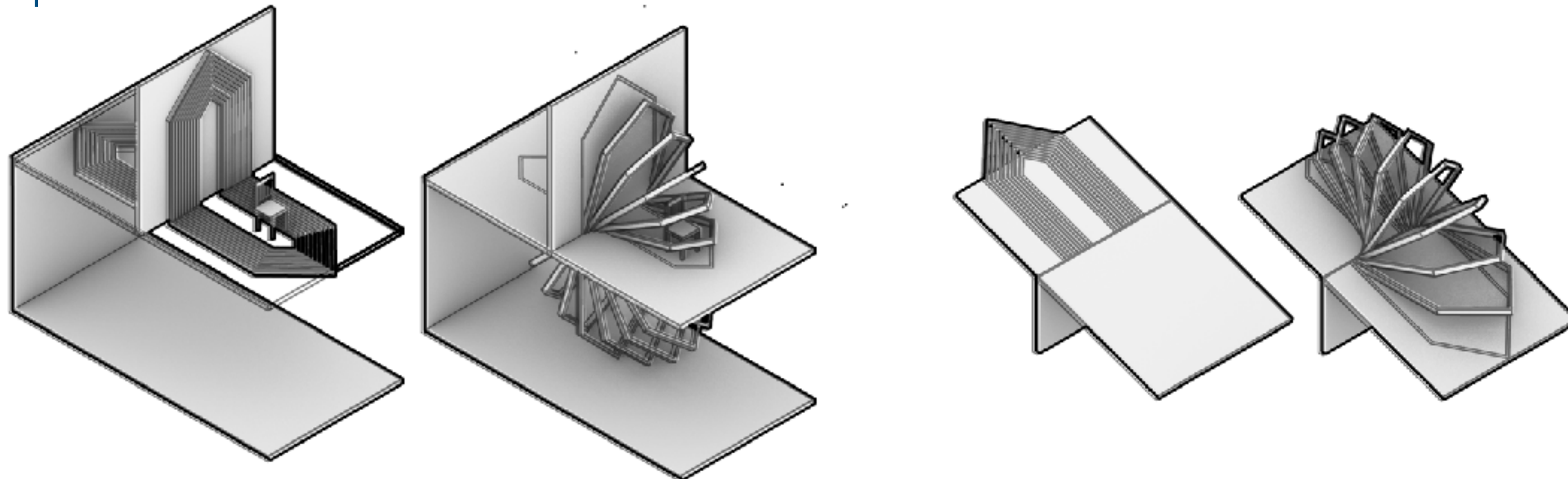

Slide/access

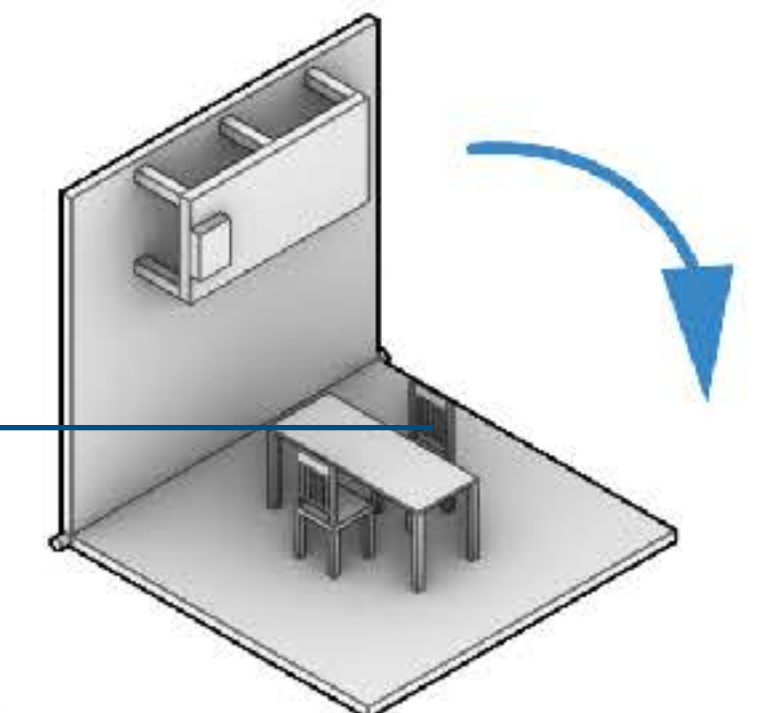
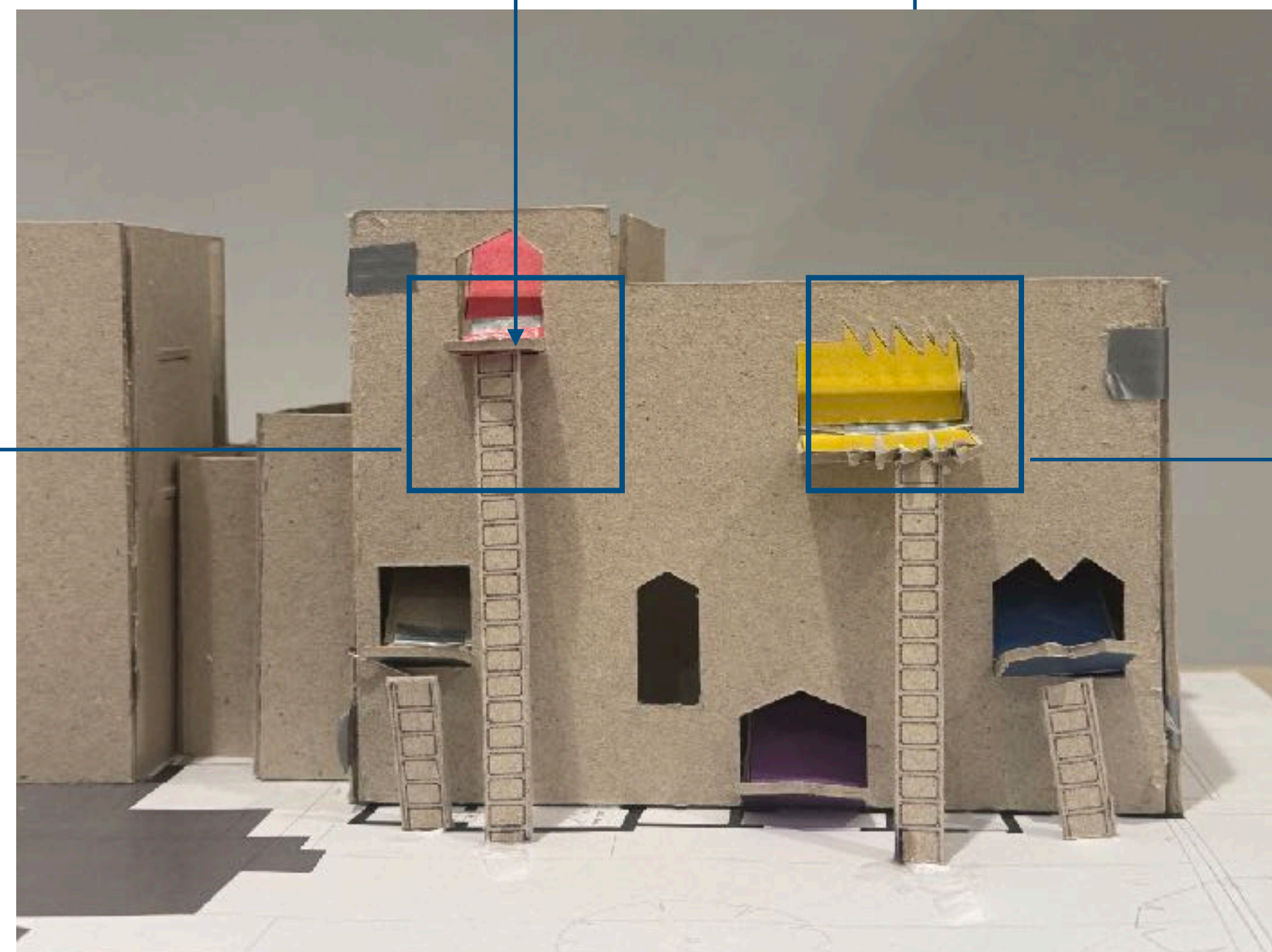
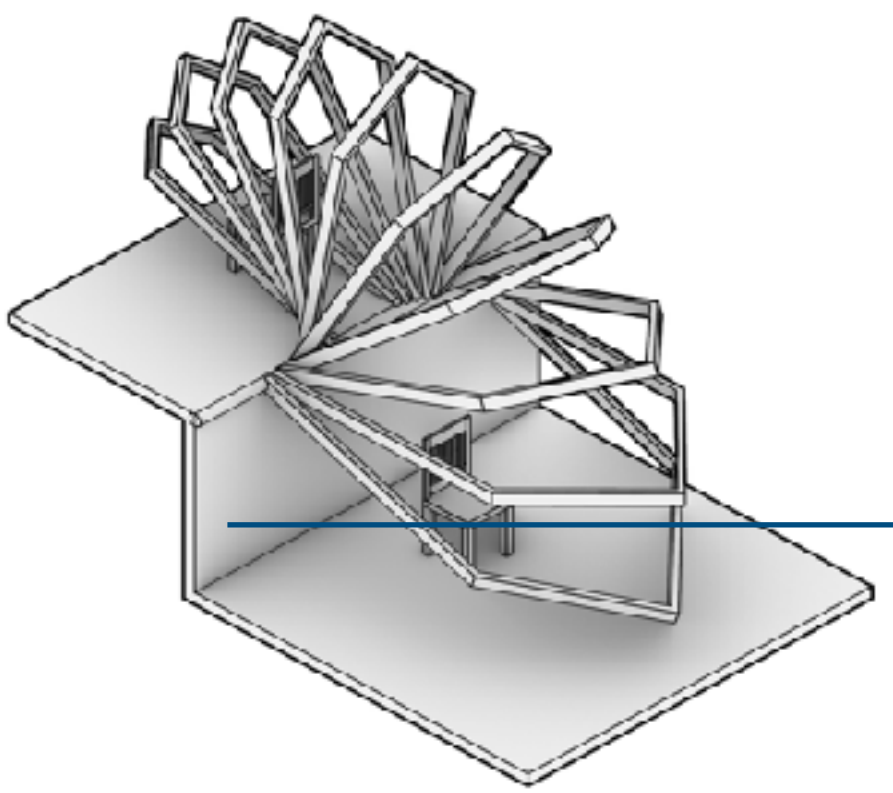
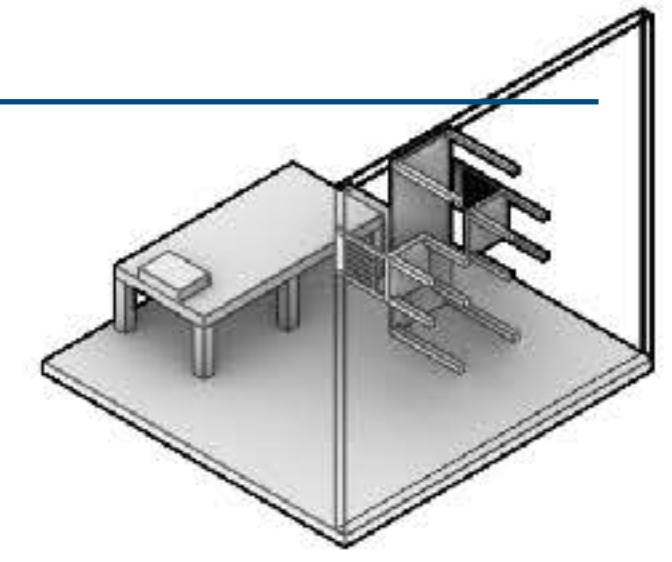
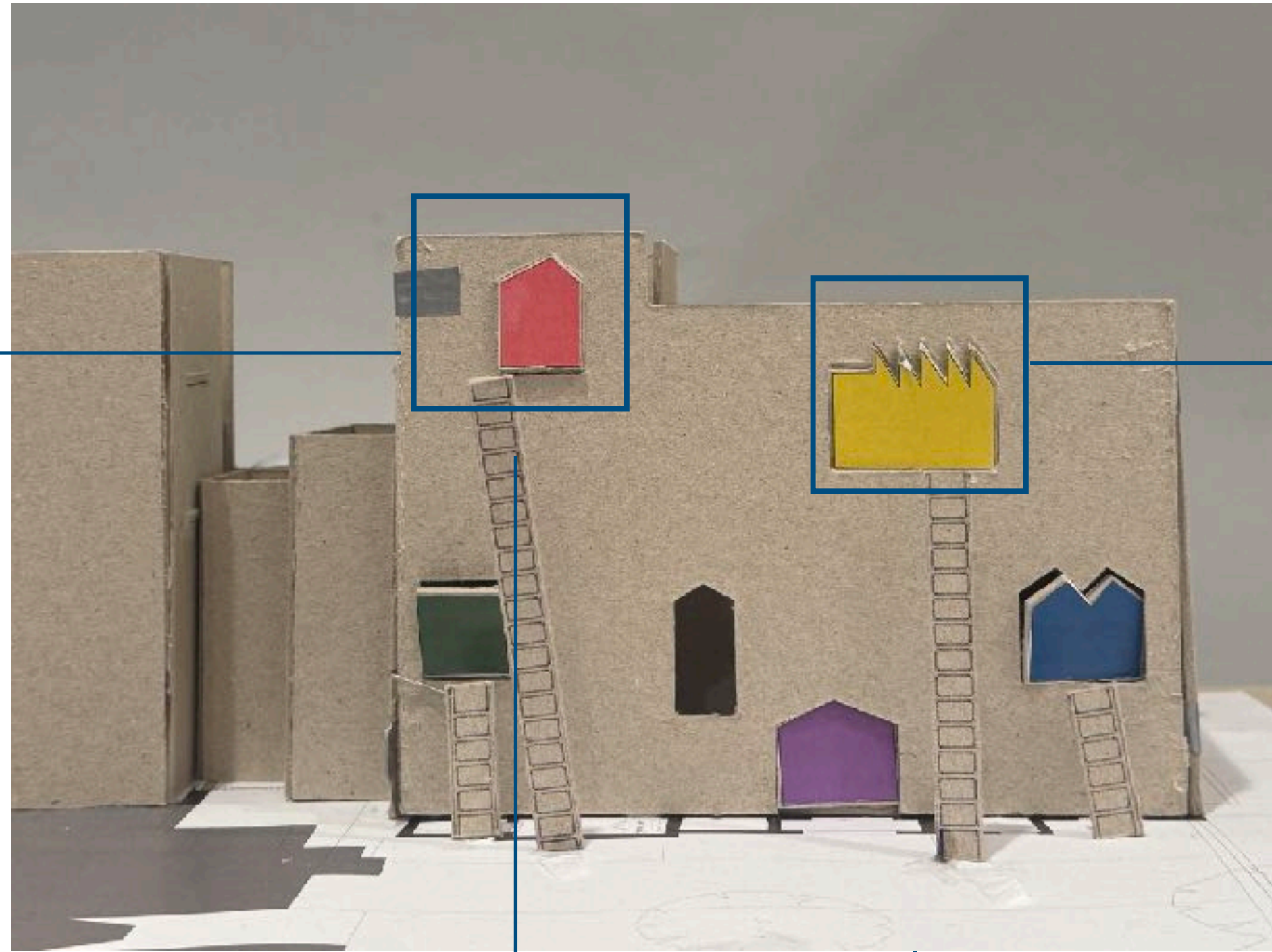
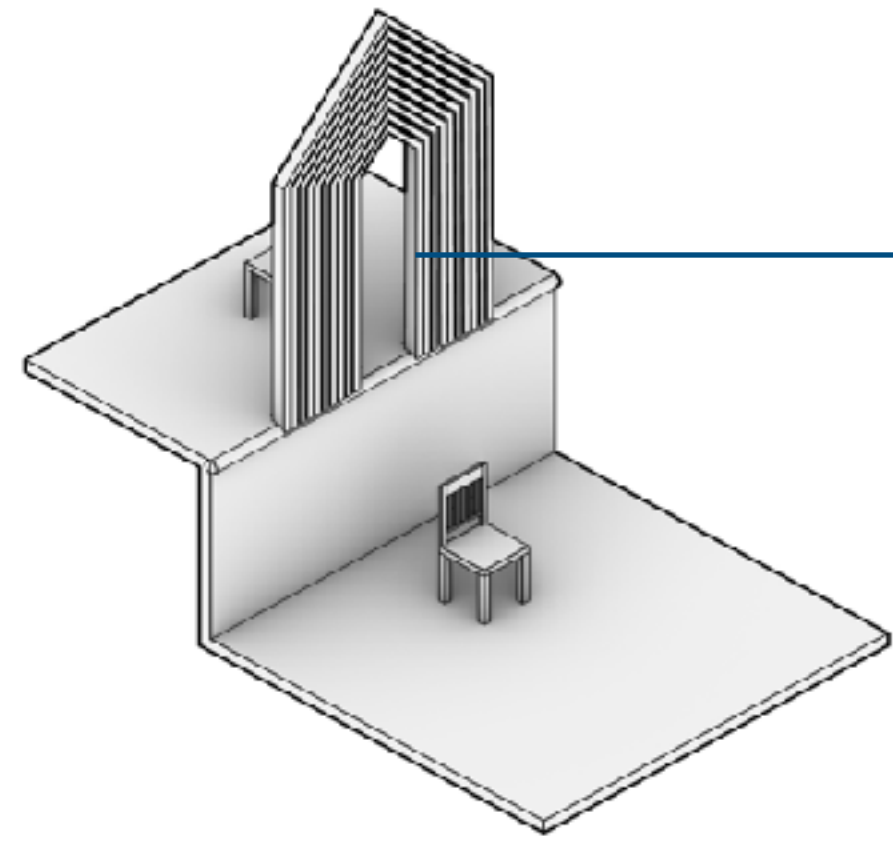



**The Gallery**      **Outdoor sports shop**      **Bakery**      **Clothing store**      **CAFE**

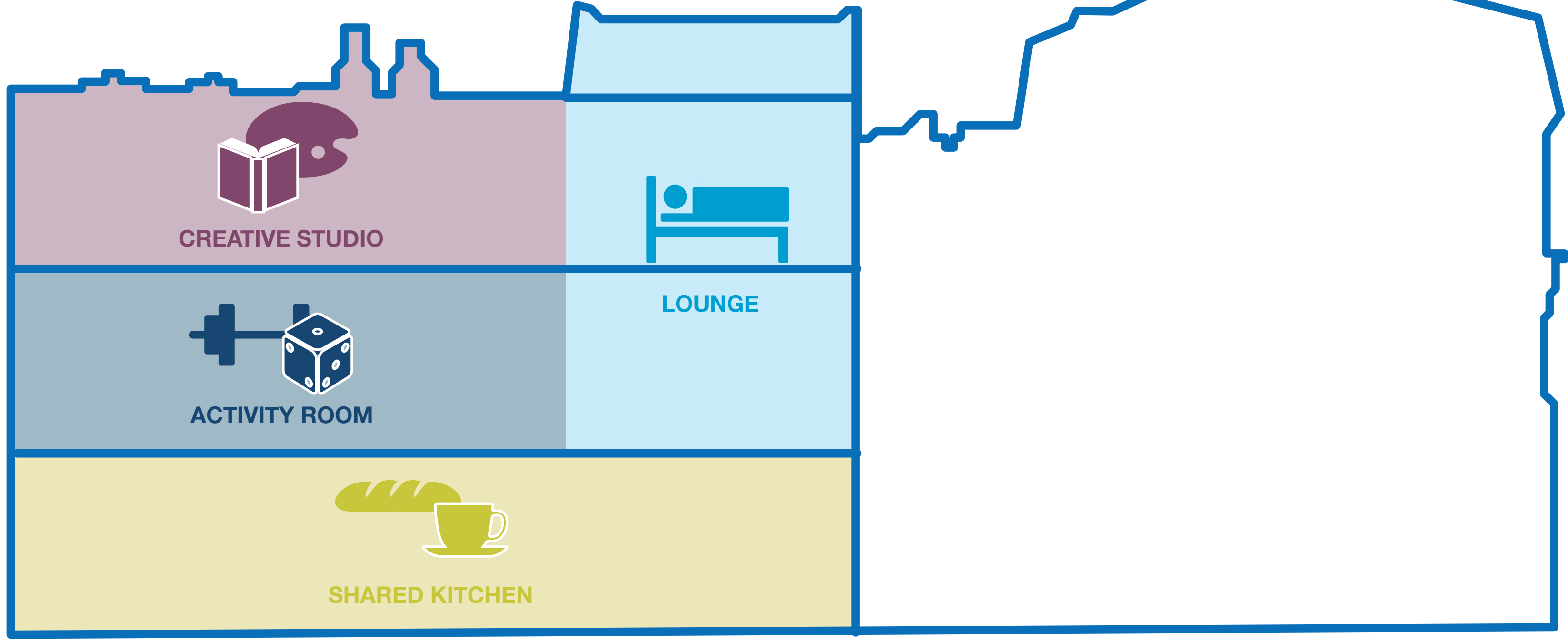
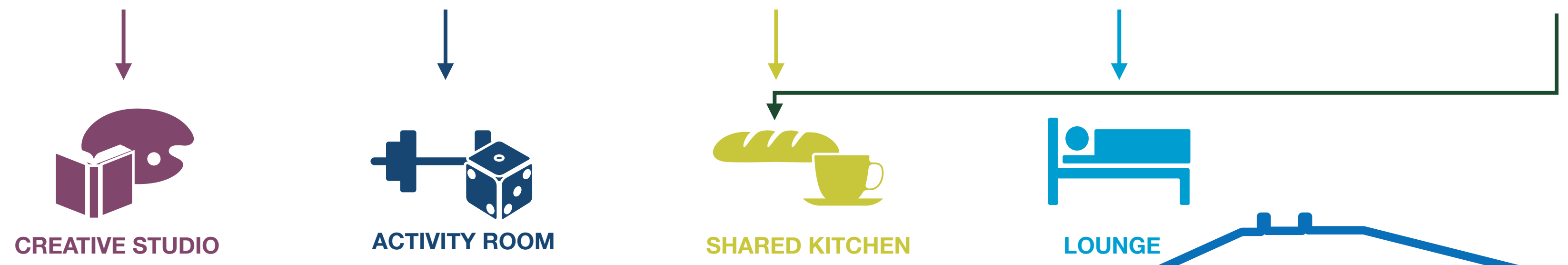

  
SHARED KITCHEN

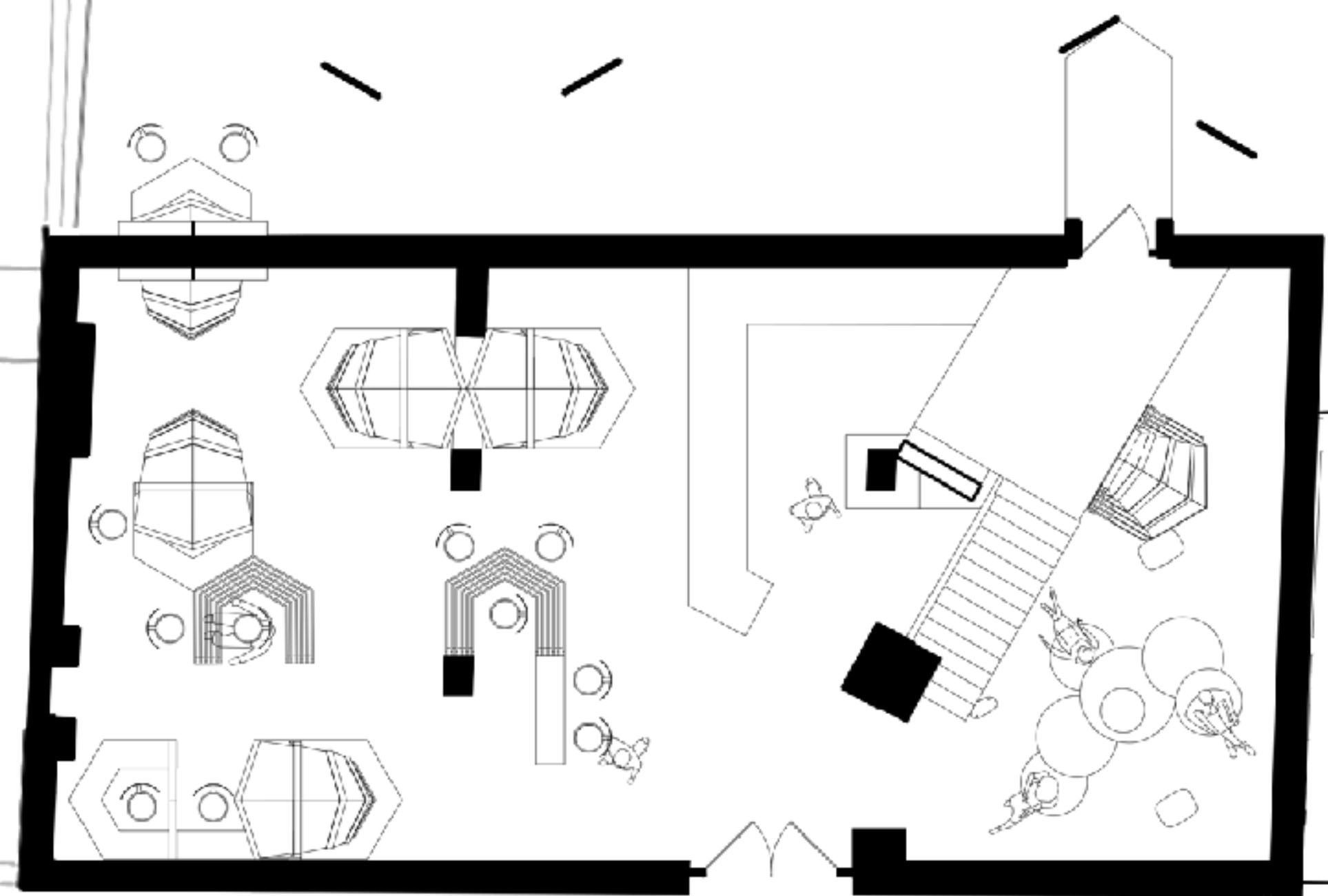

Plan- Ground Floor

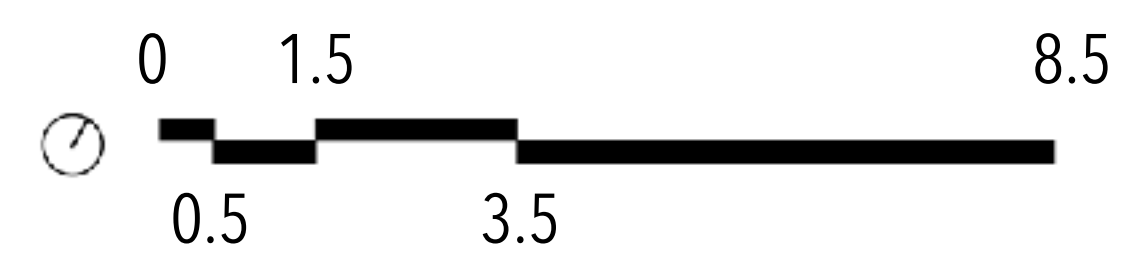

  
ACTIVITY ROOM

  
LOUNGE

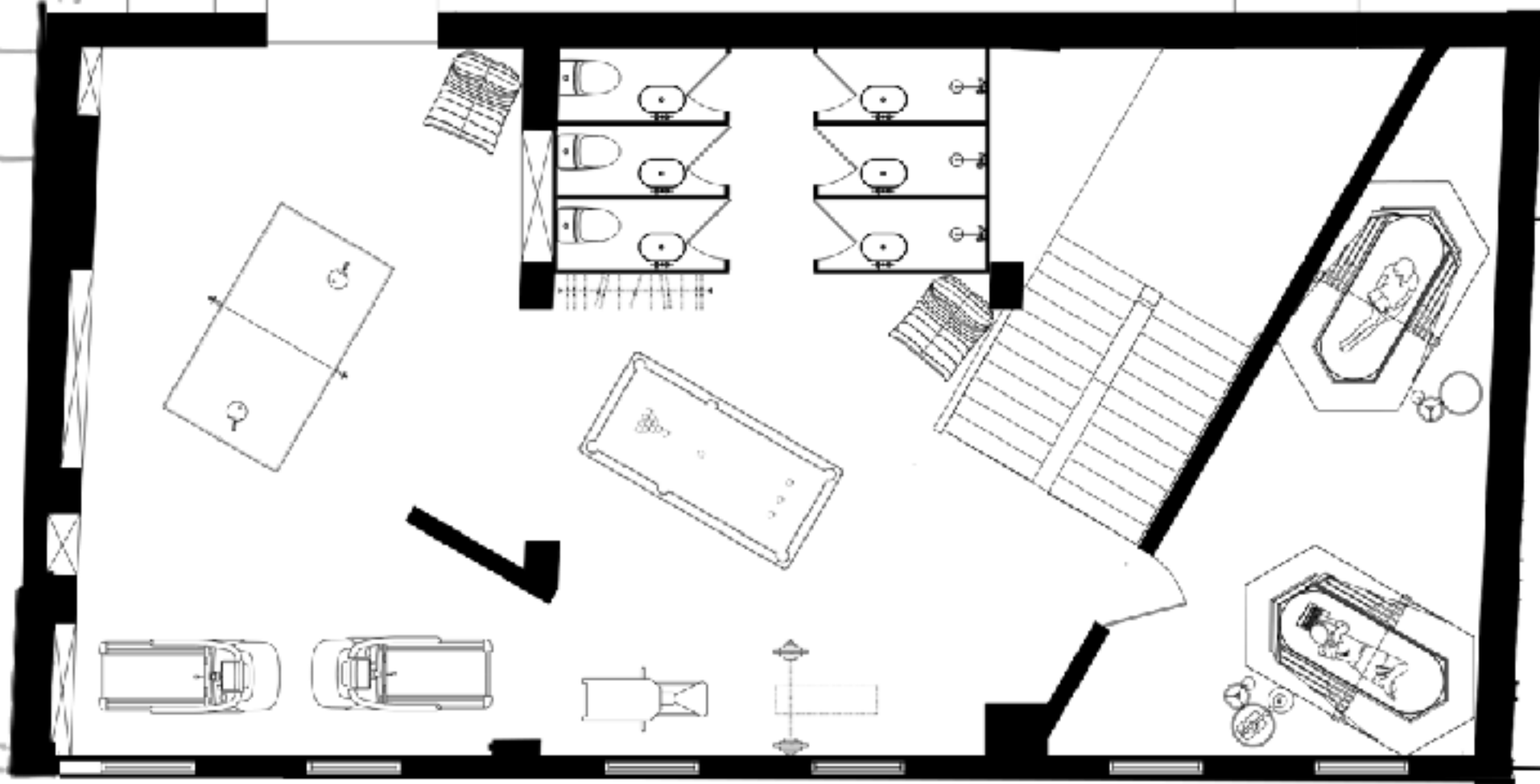

Plan- First Floor

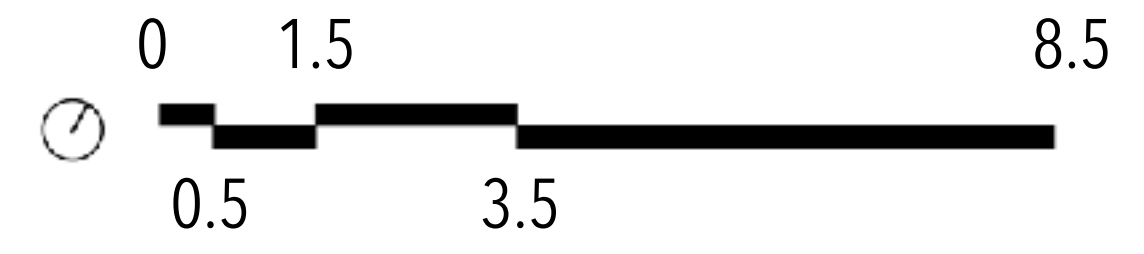



CREATIVE STUDIO

LOUNGE

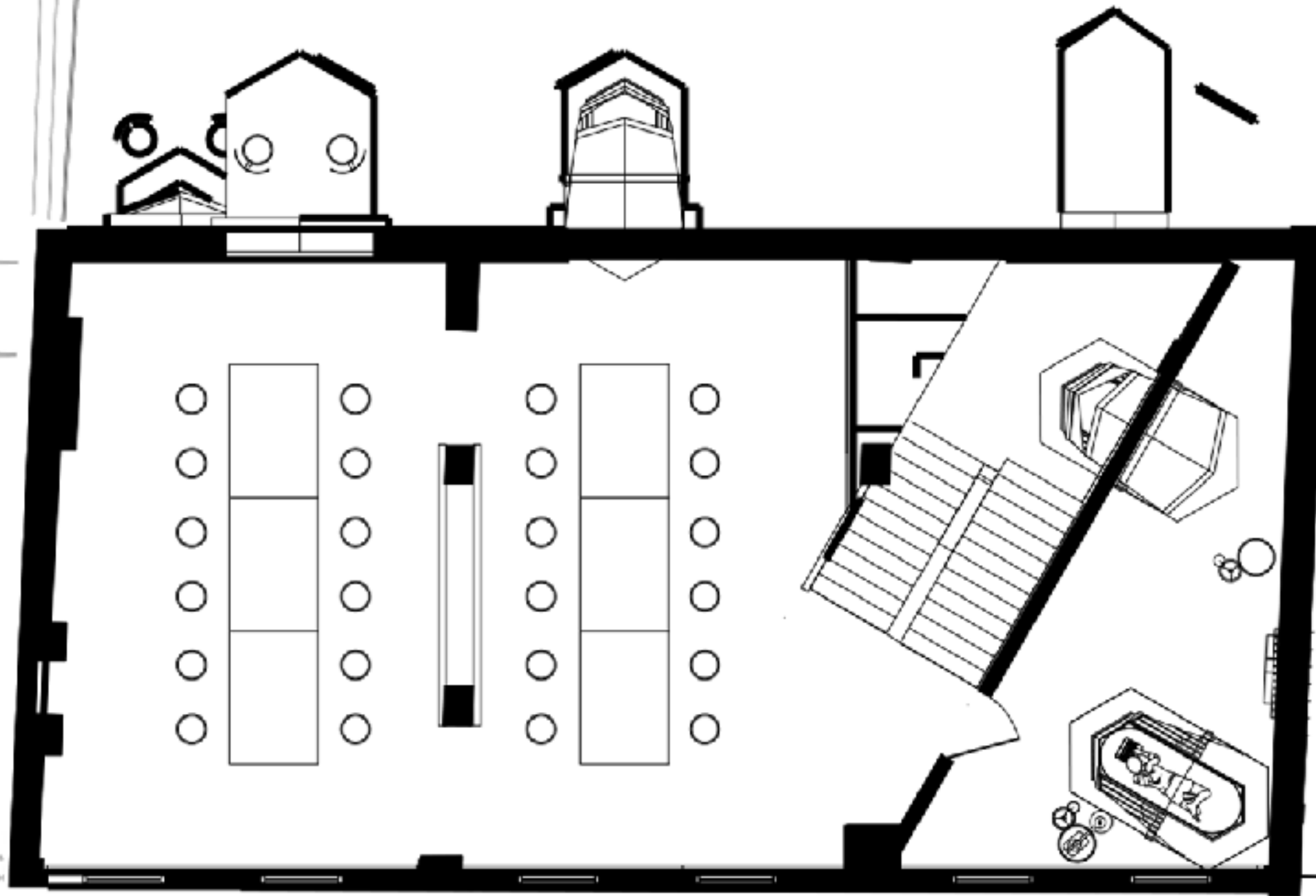

Plan- Second Floor

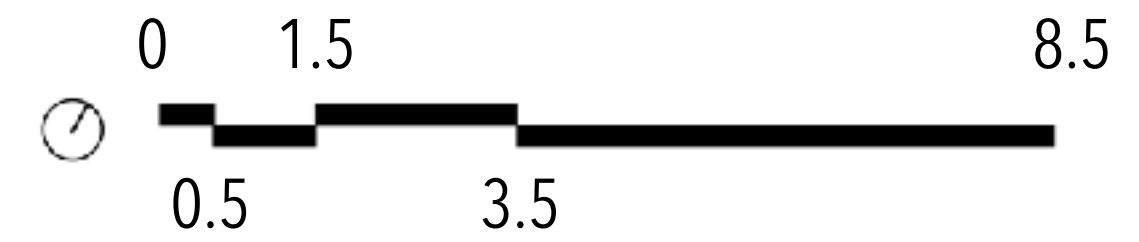



LOUNGE

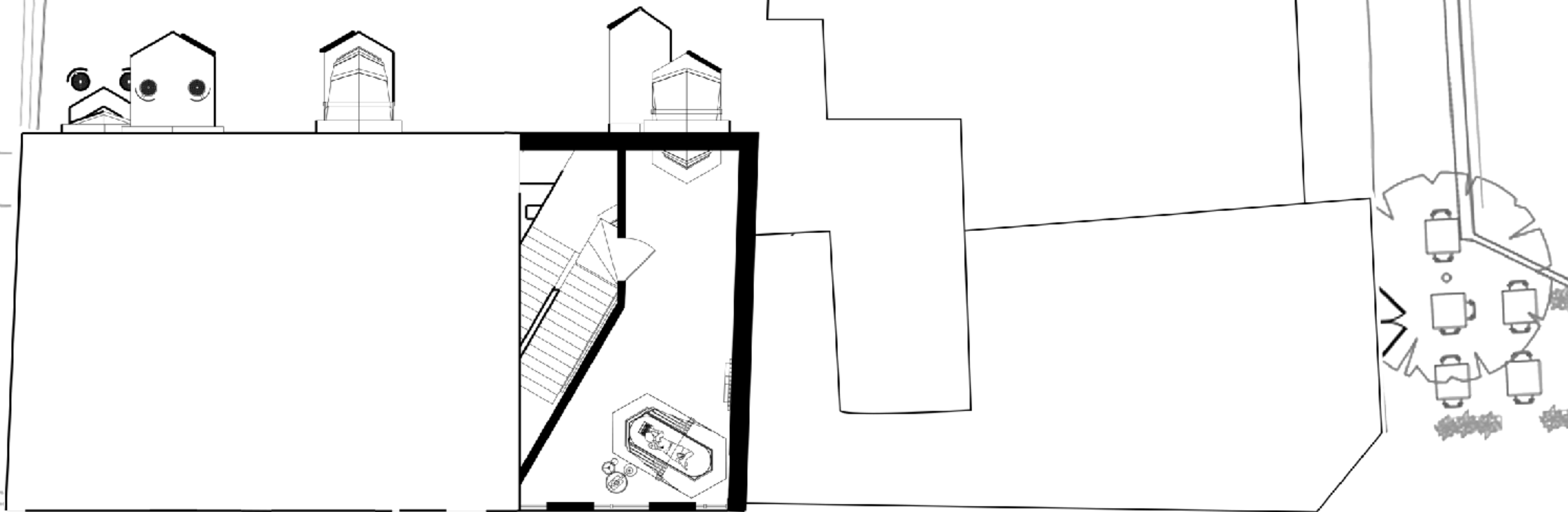

Plan- Third Floor

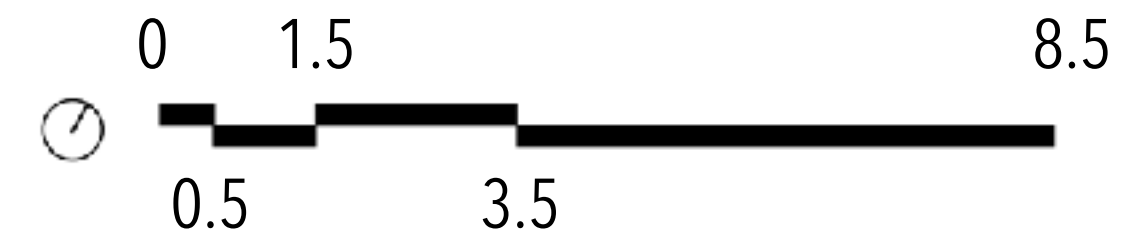



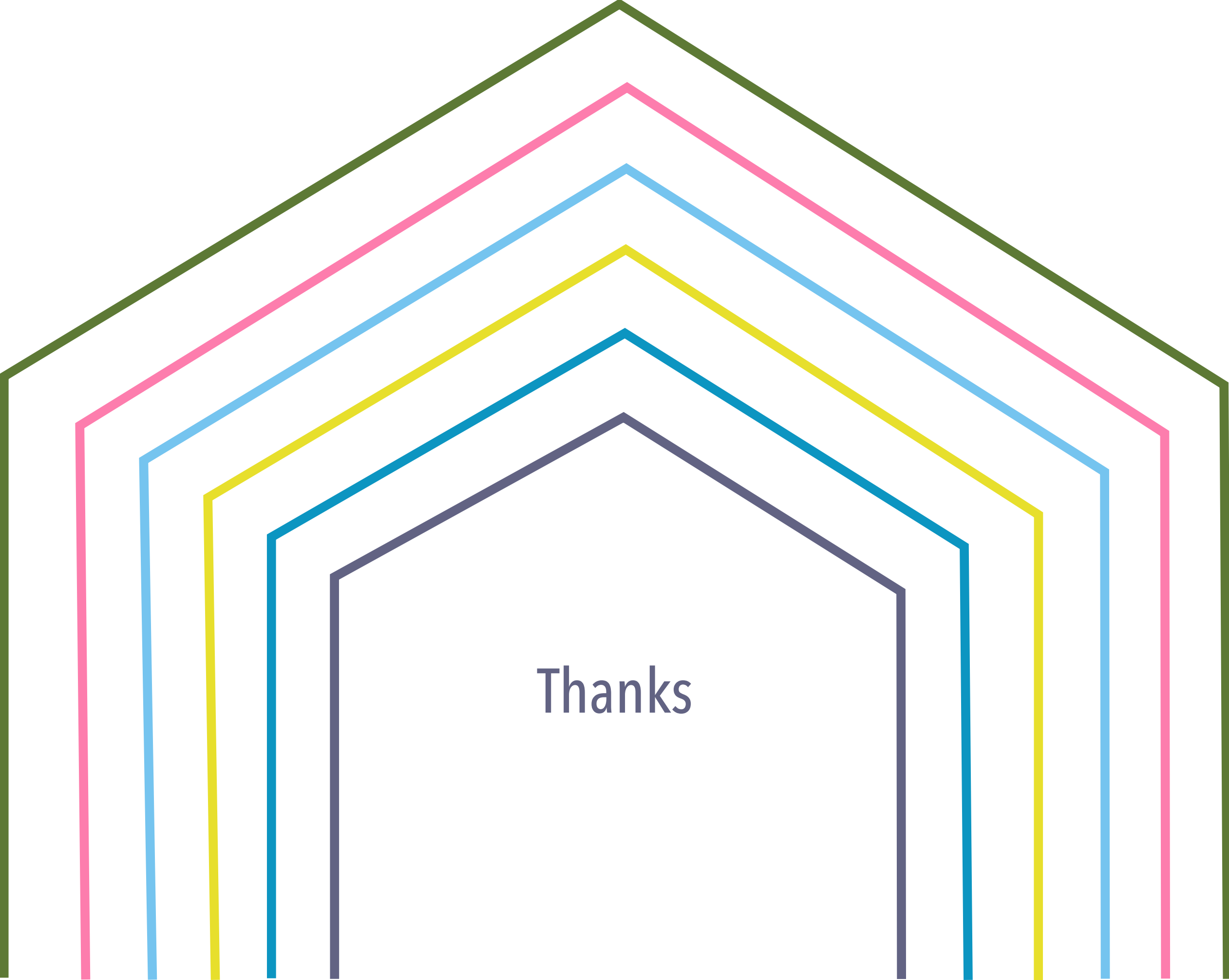

Thanks