

COLUMNS PARADIGM

XINYI GE

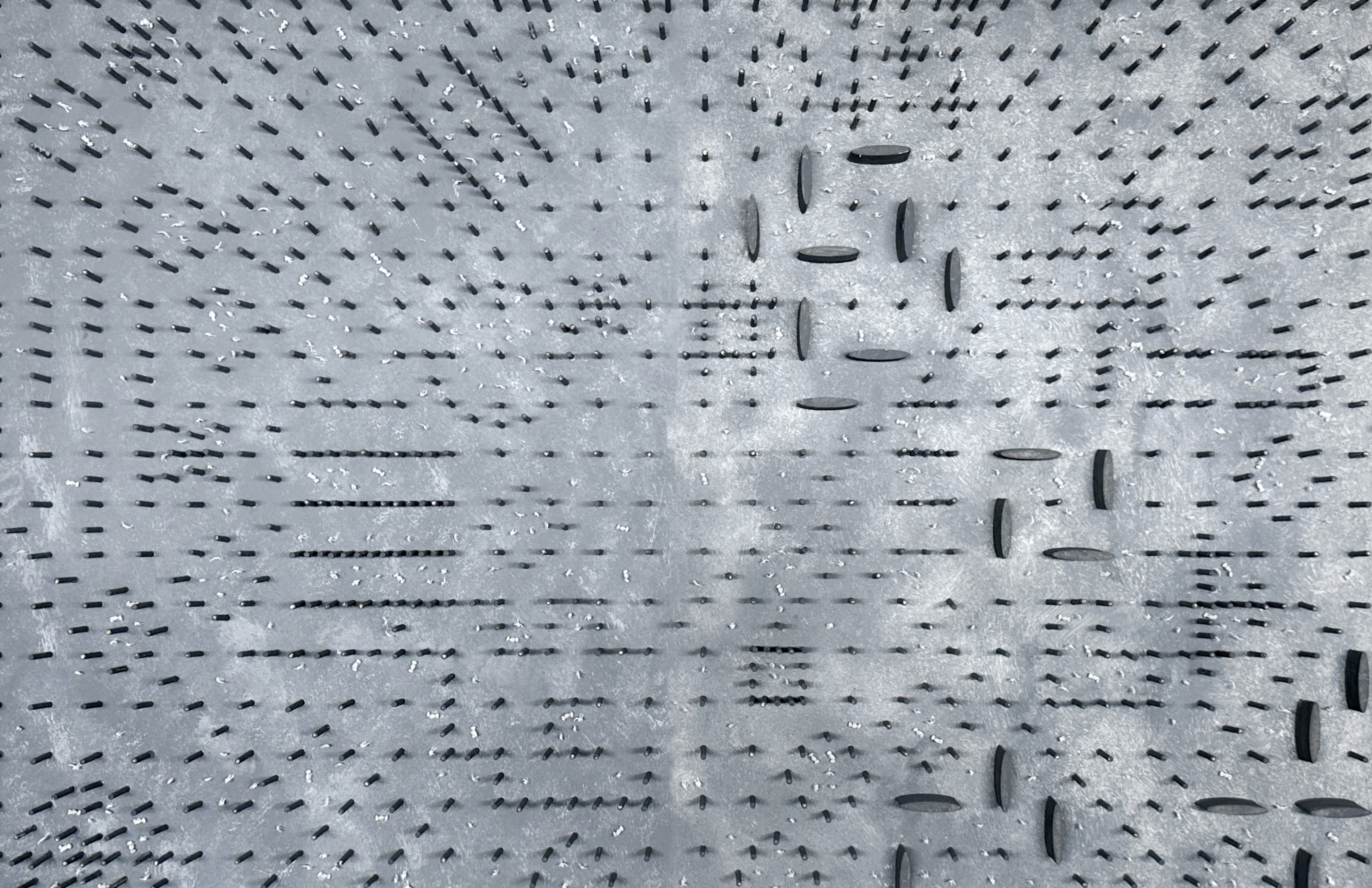

I. SITE ANALYSIS

II. DESIGN STRATEGY

III. PROGRAMME

IV. PROPOSAL

I. SITE ANALYSIS

It used to be a factory in east London. The layout of the existing columns is based on a grid system, which is unique and is the potential of the space.

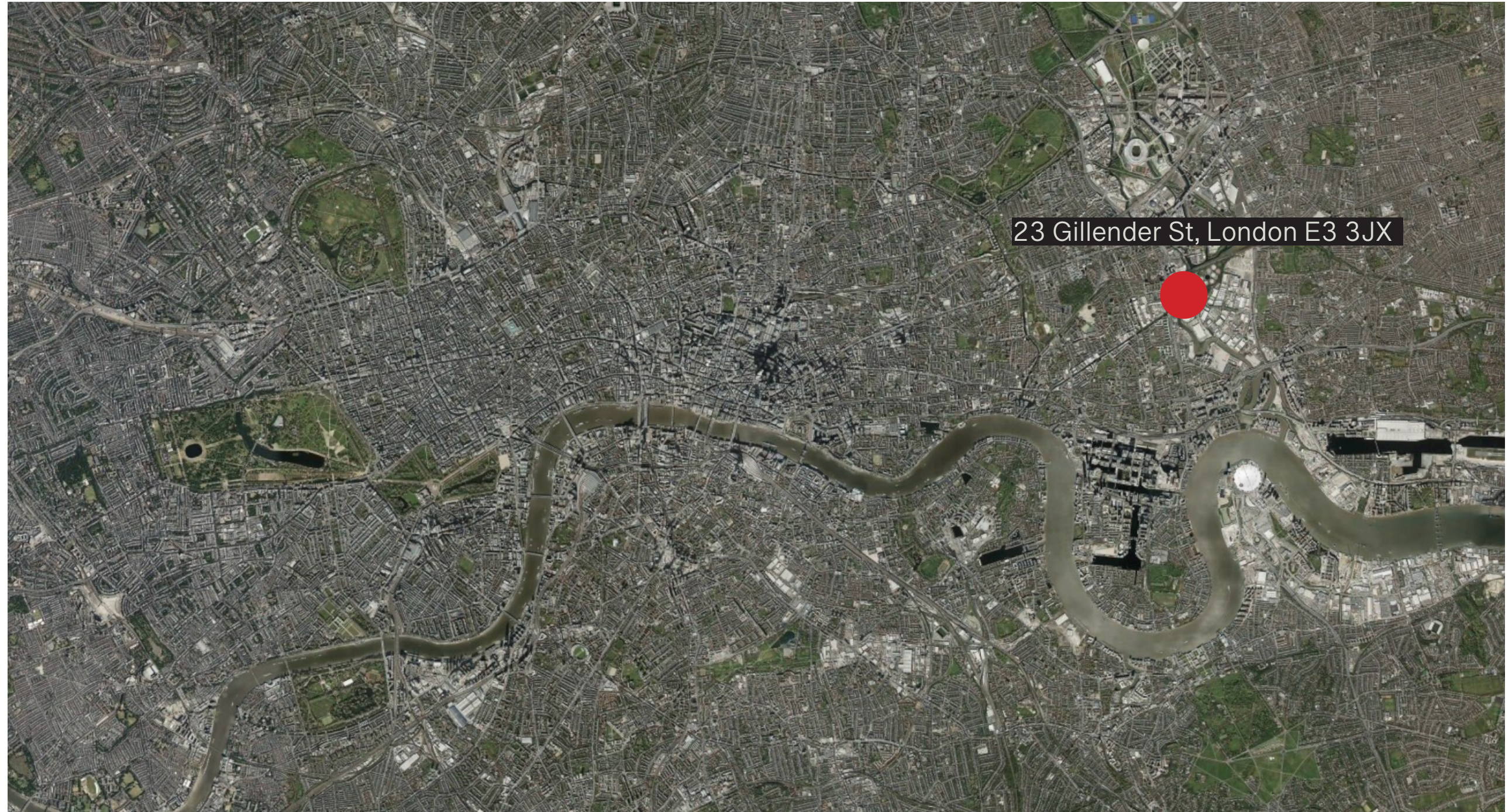

23 Gillender St, London E3 3JX

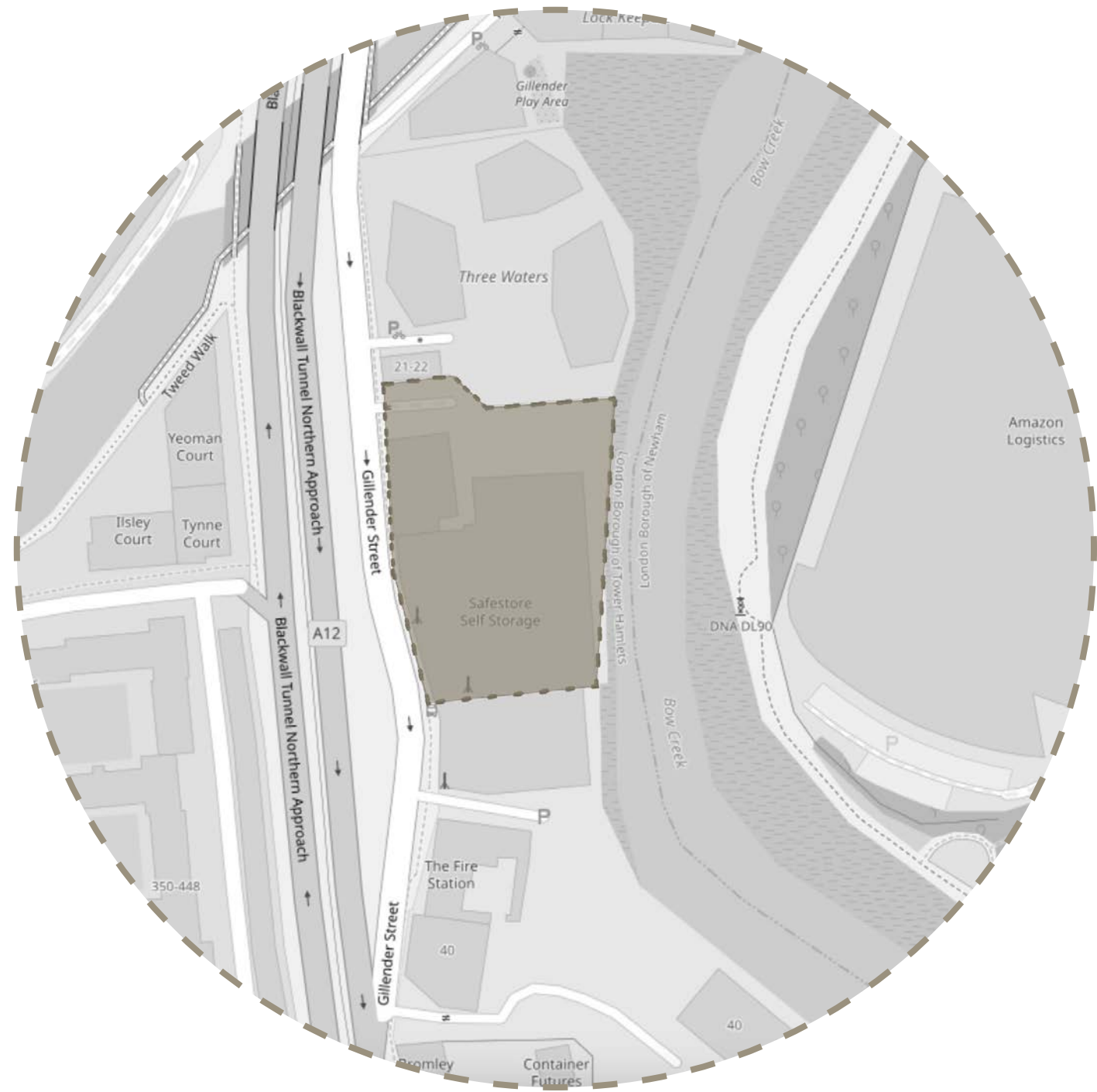

Location: 23 Gillender St



Building Street View



Building Cutout

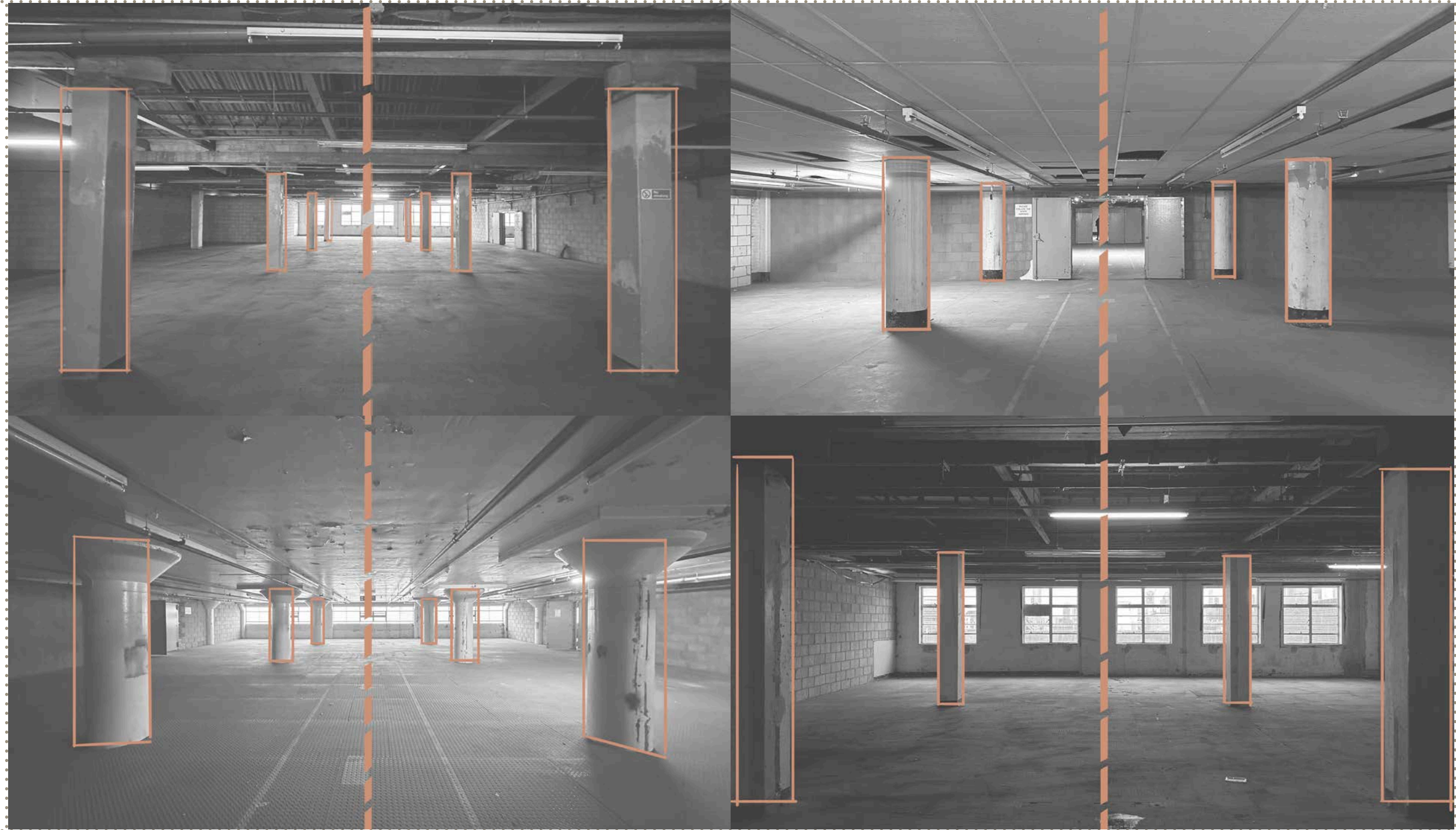

Symmetry | Grid | Axis | Order | Repeat | Columns

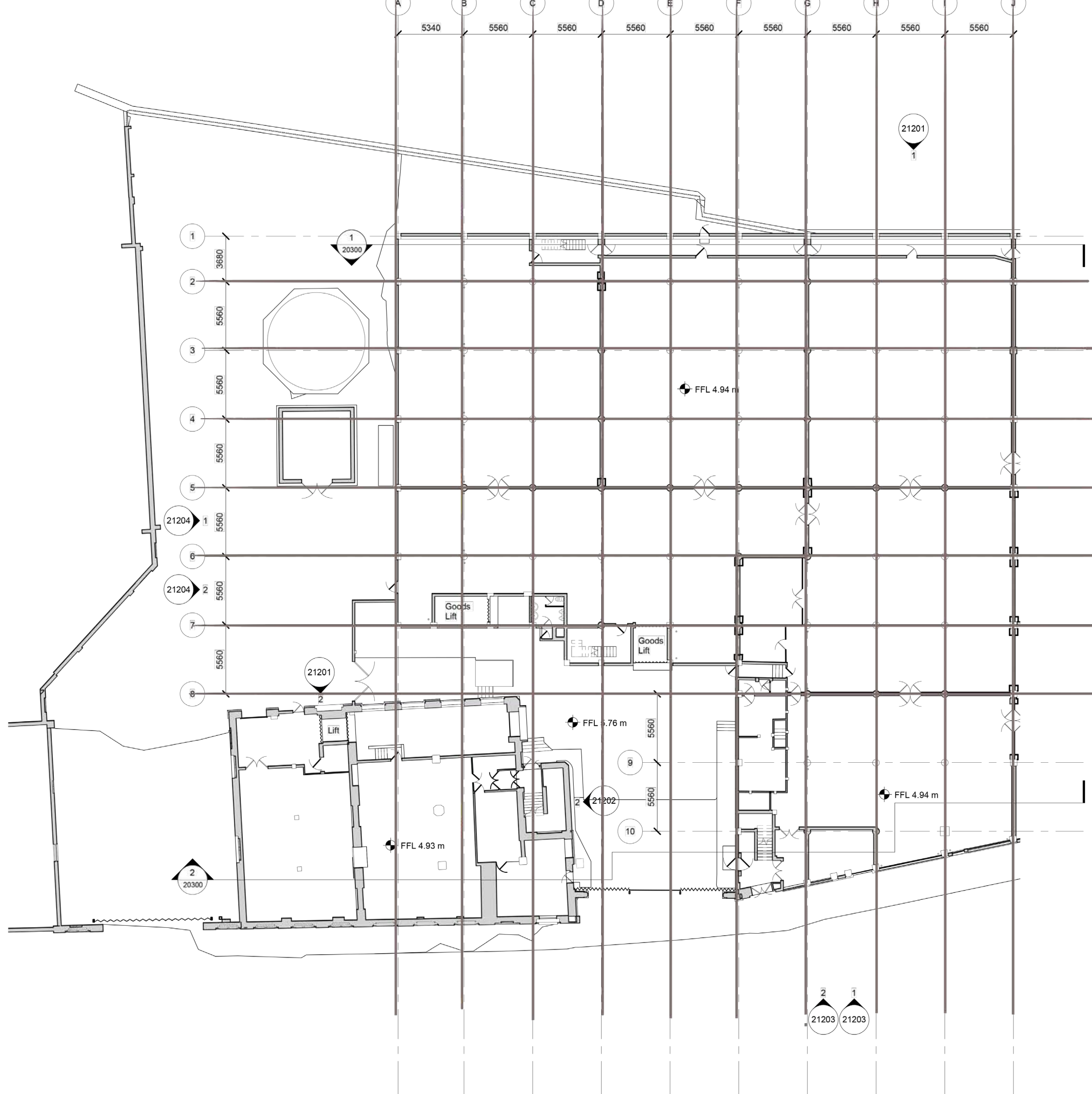

Existing floor plan with grid system

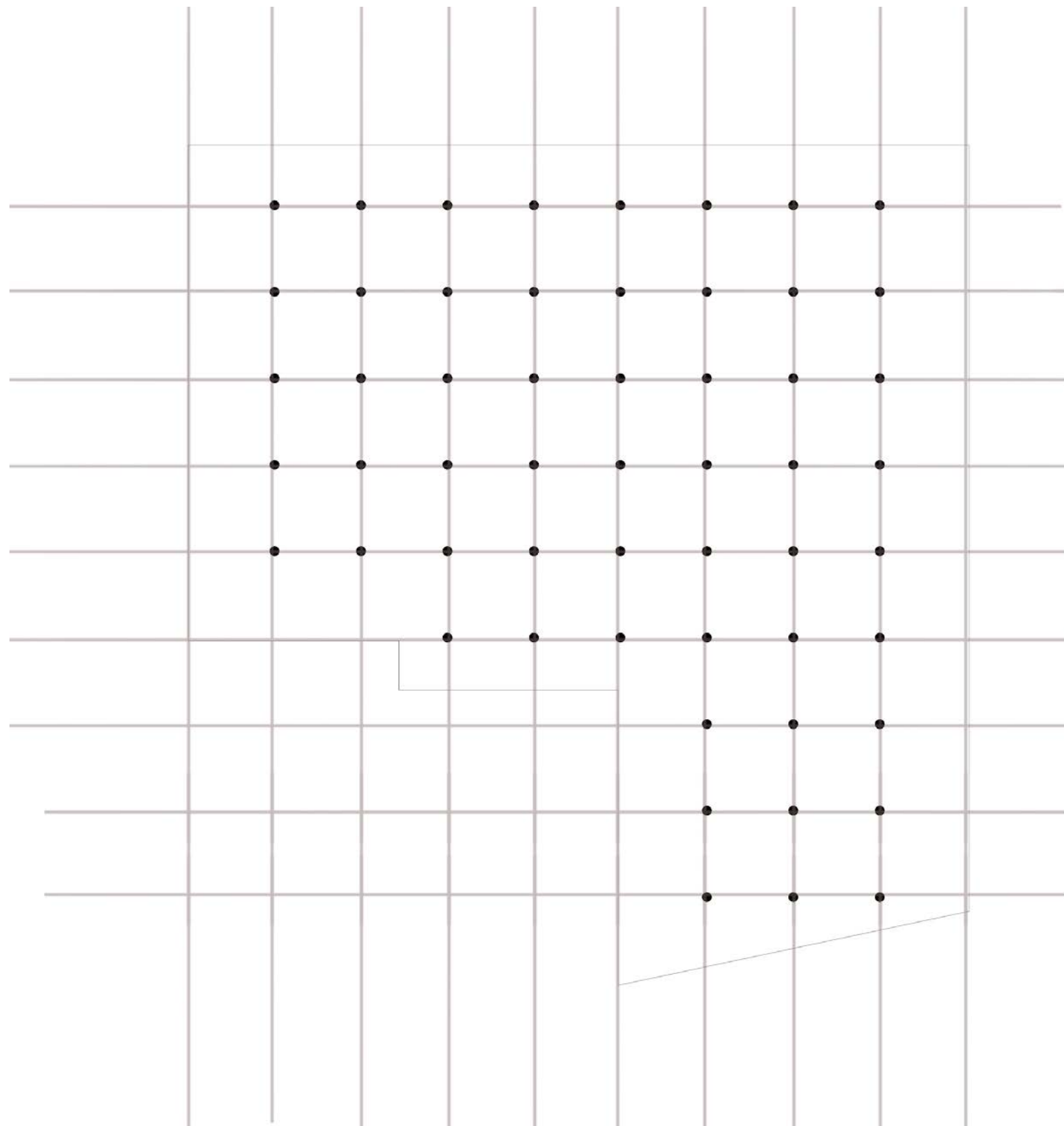

The potential of the building:
Columns layout followed in grid system

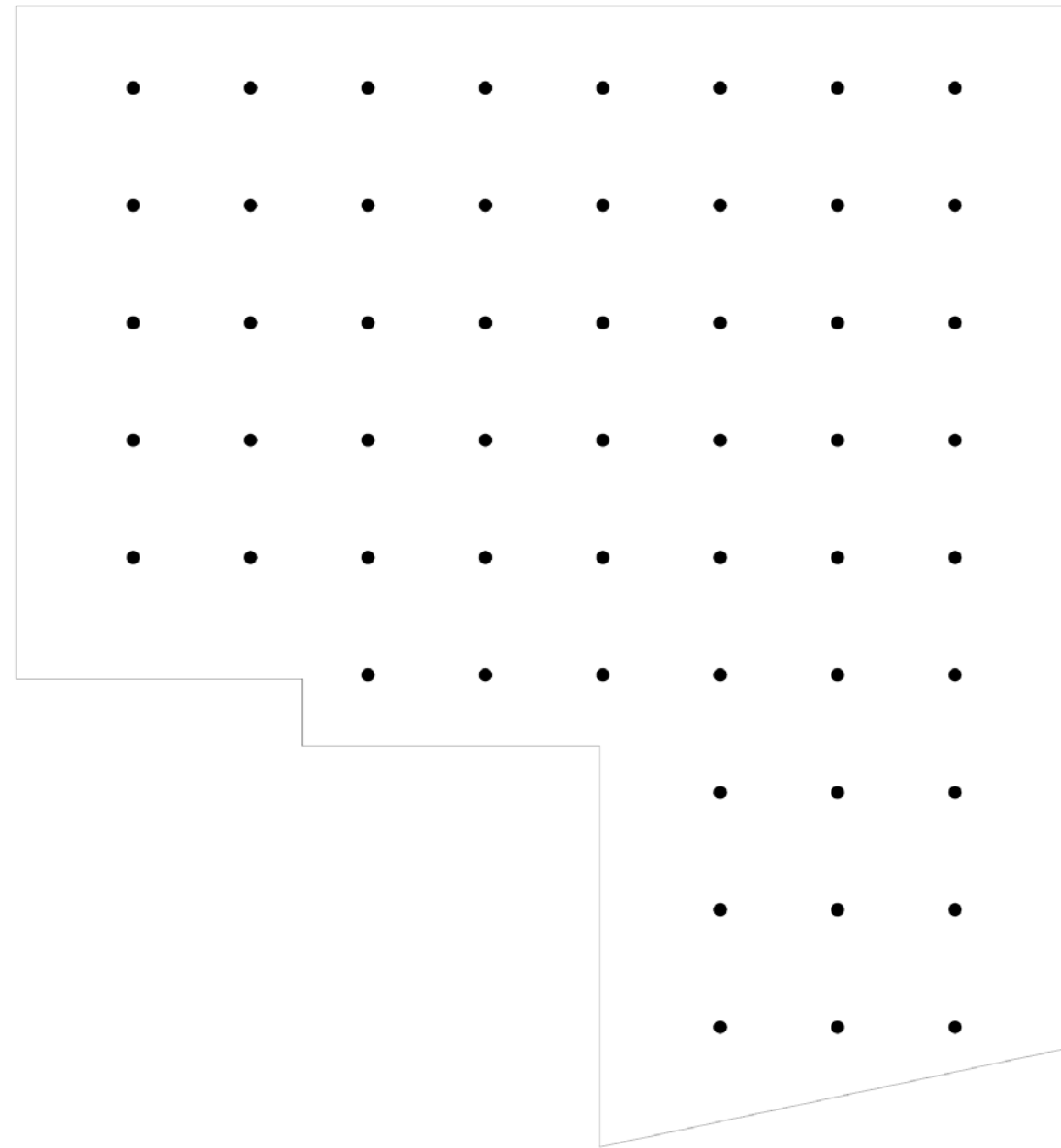

Existing columns layout



It tilted



It collapsed

II. DESIGN STRATEGY

After some failed trials, I tried other ways to hack the system, including adding more columns and changing the columns' shapes. If one unit of the grid is changed and applied to all units, the original system will be amended, and the simple grid system will get more complexity. After hacking the system, the columns create a lot of different spatial experiences.

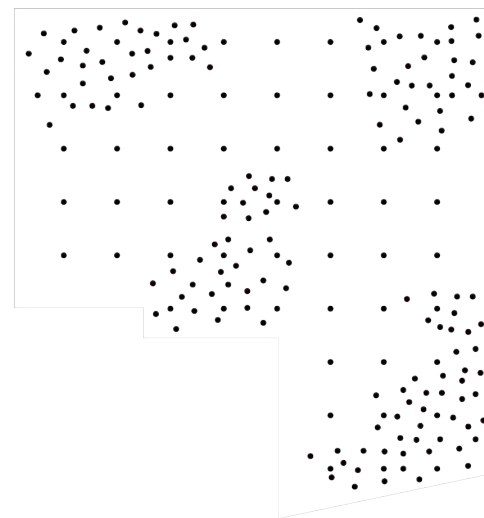
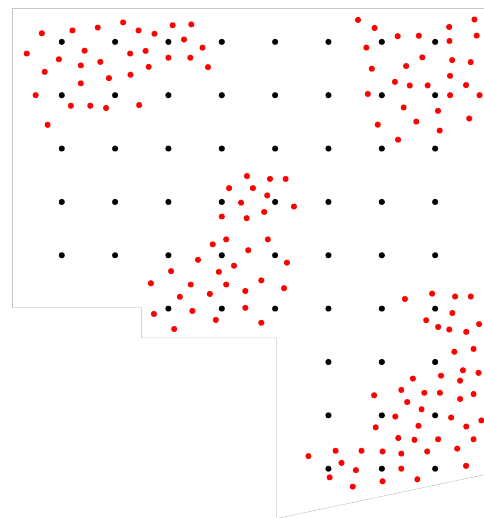
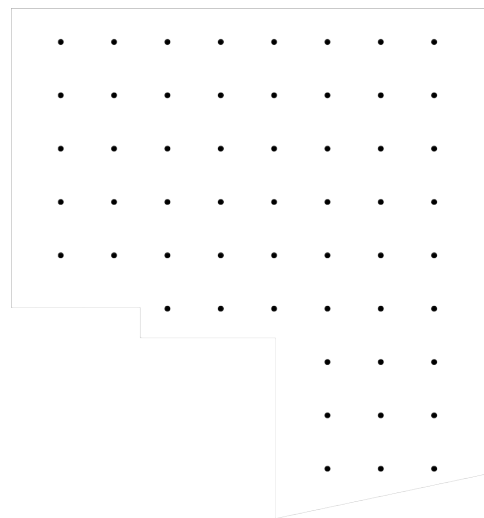
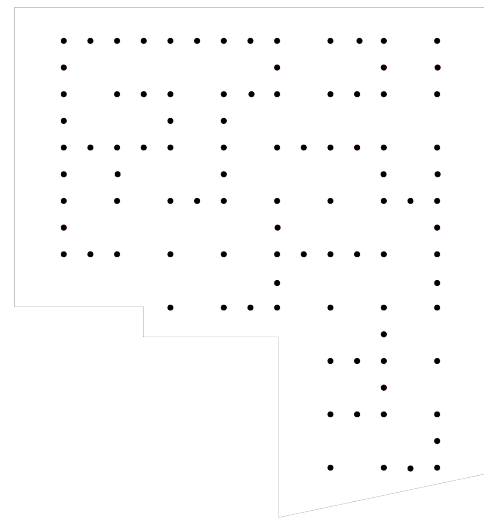
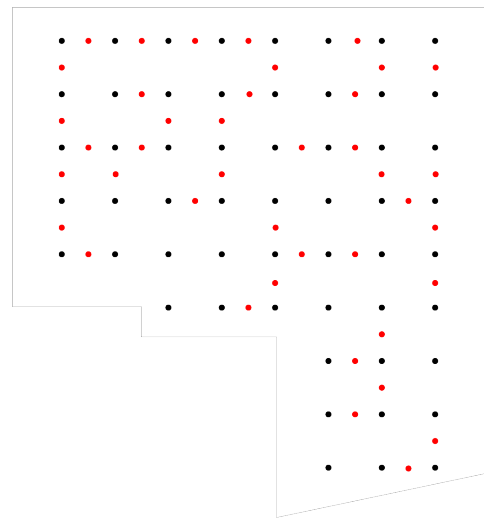
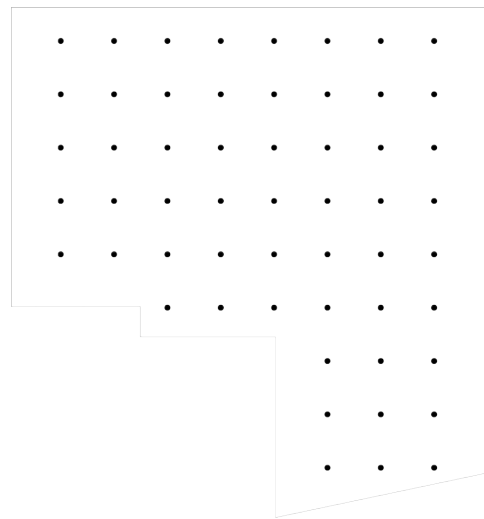

Adding more columns...

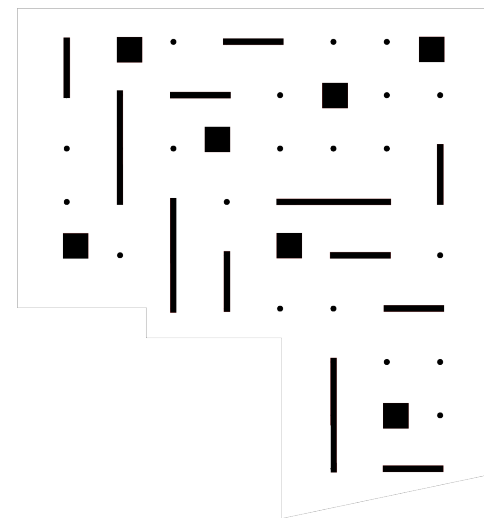
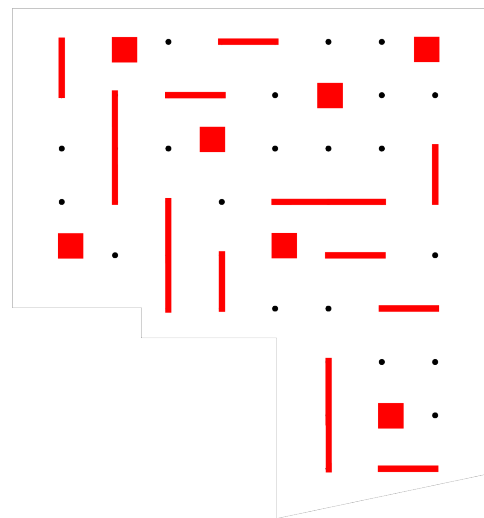
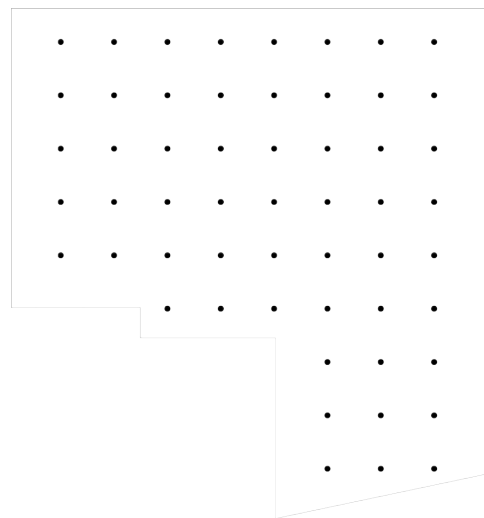
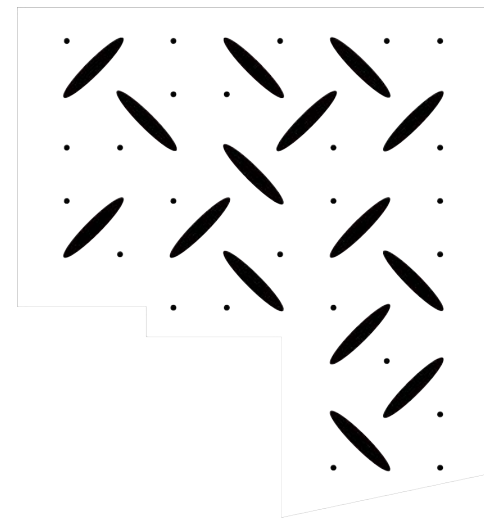
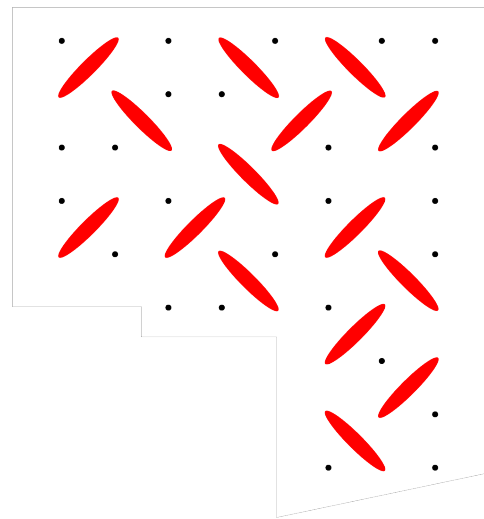
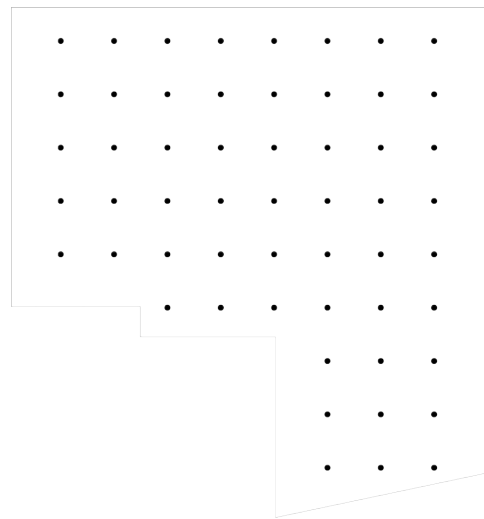

Changing column shapes...

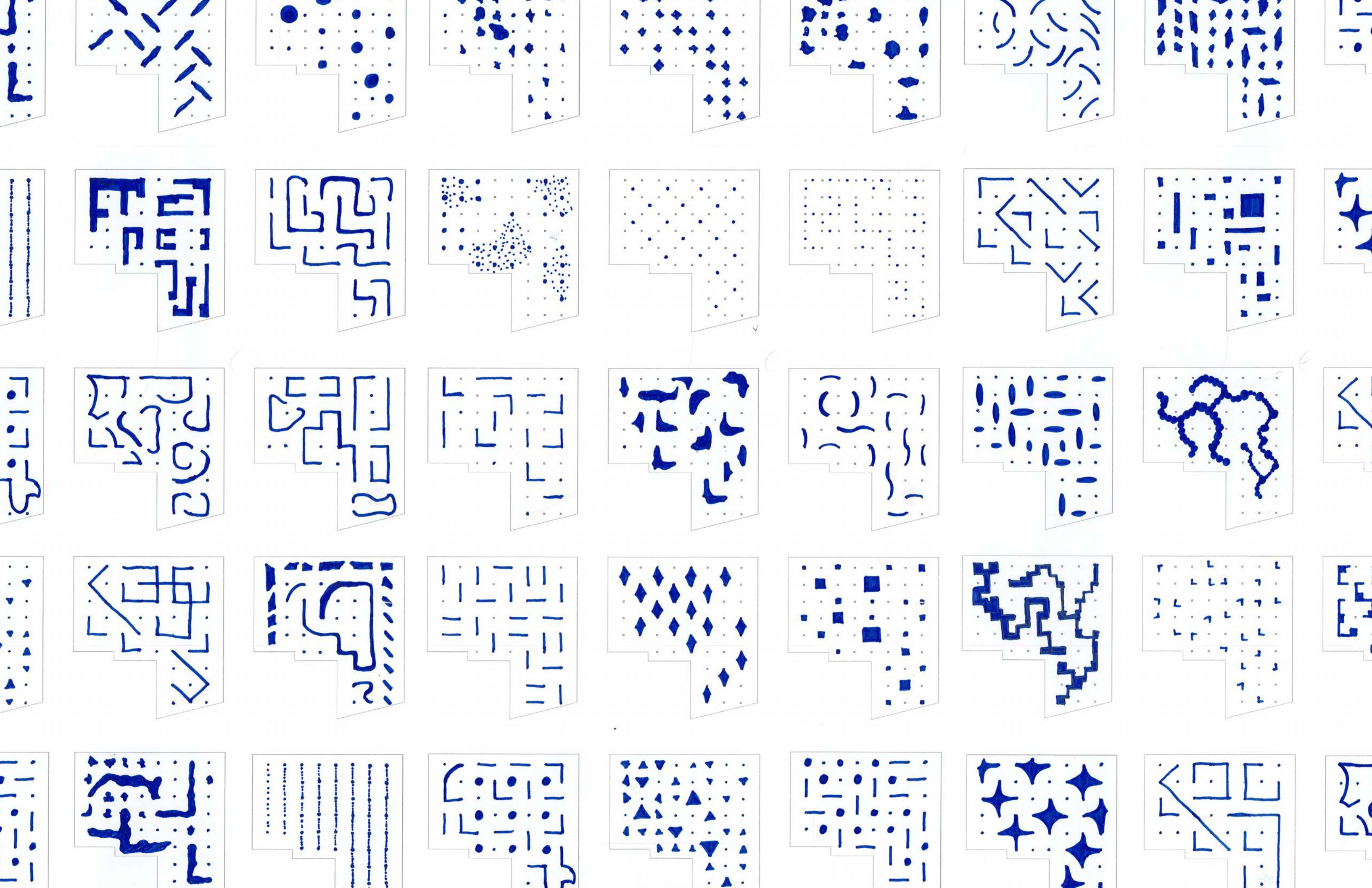

In One Unit...

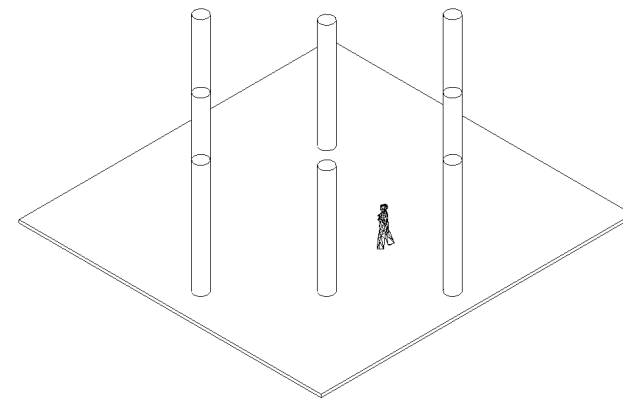
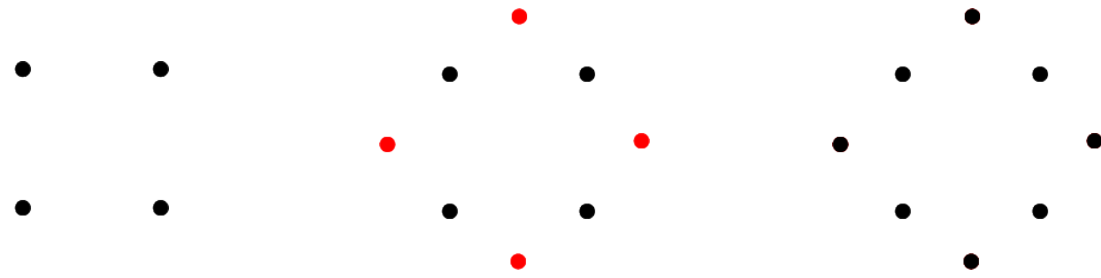
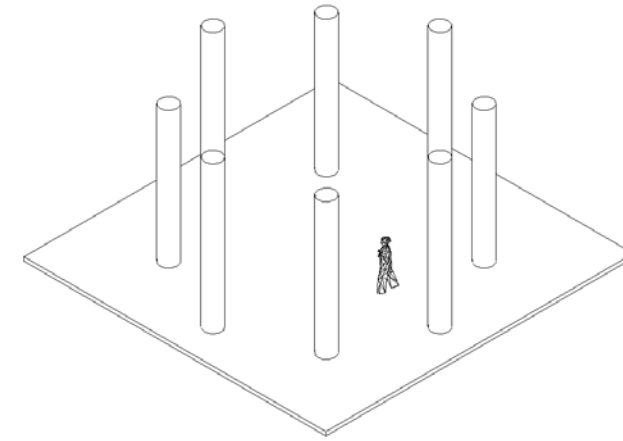
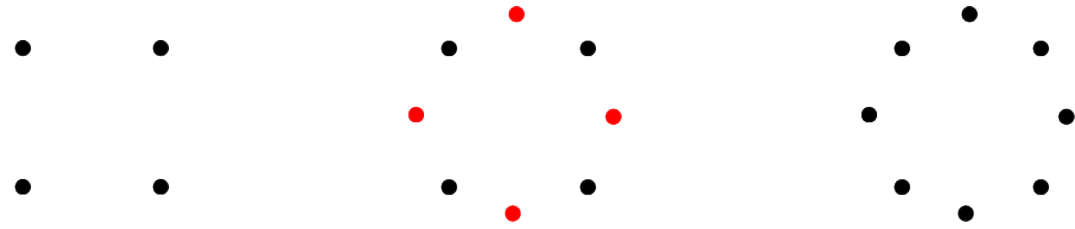

In More Units...

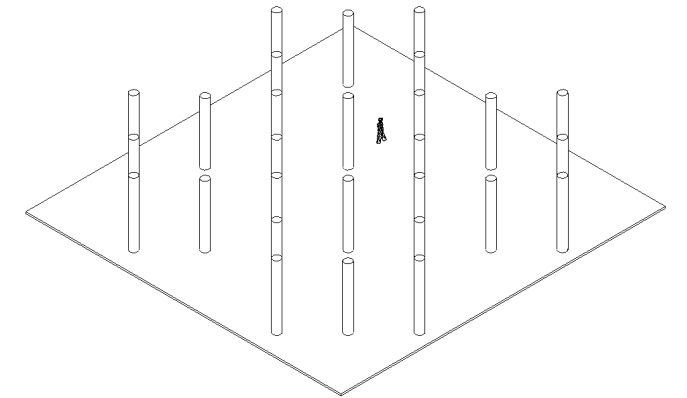
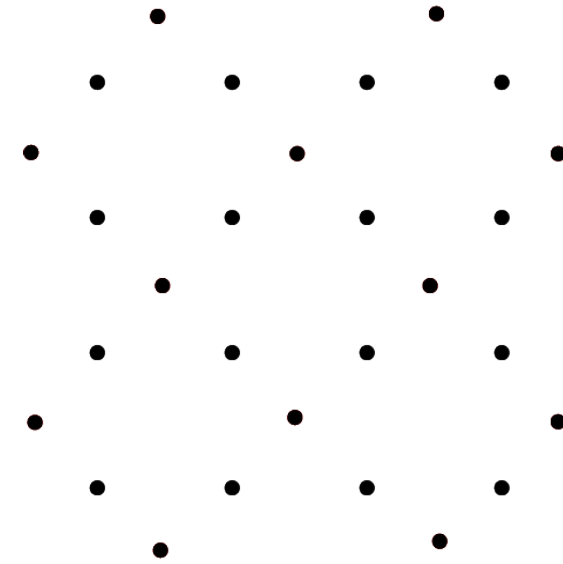
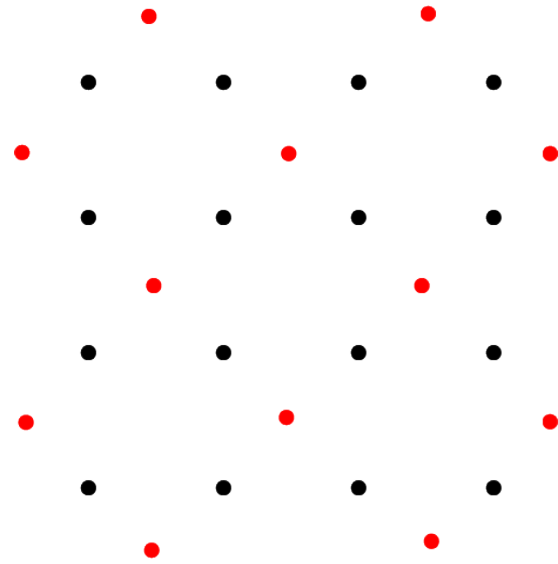
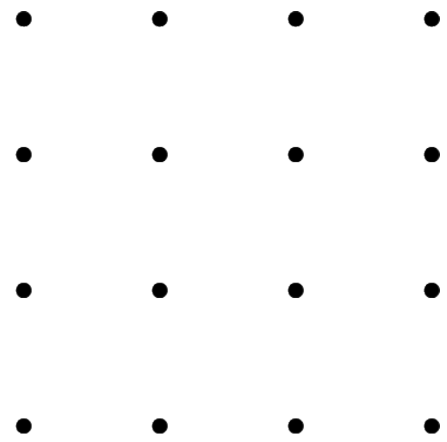
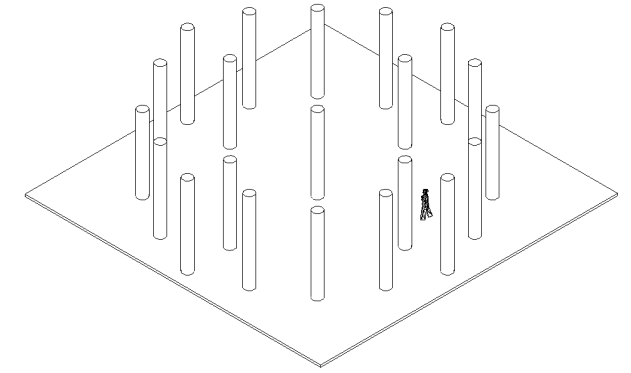
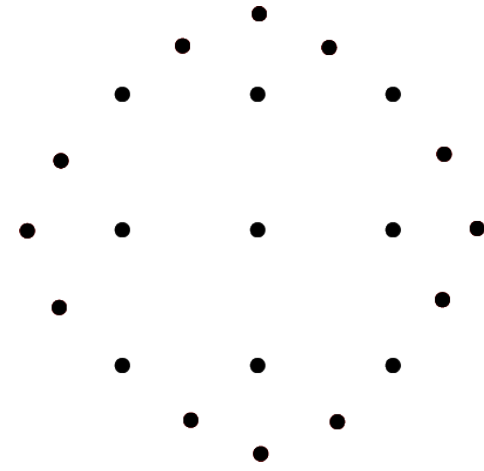
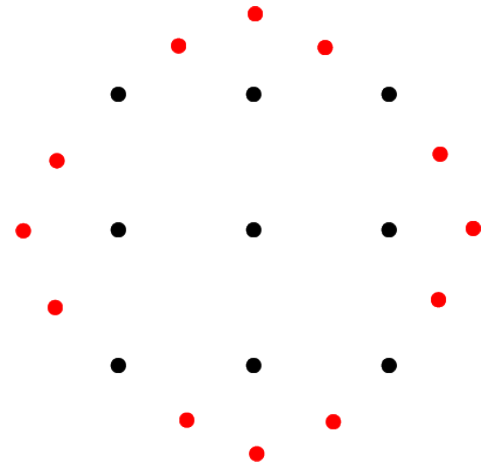
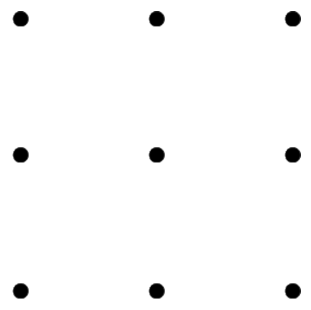

Concept Model

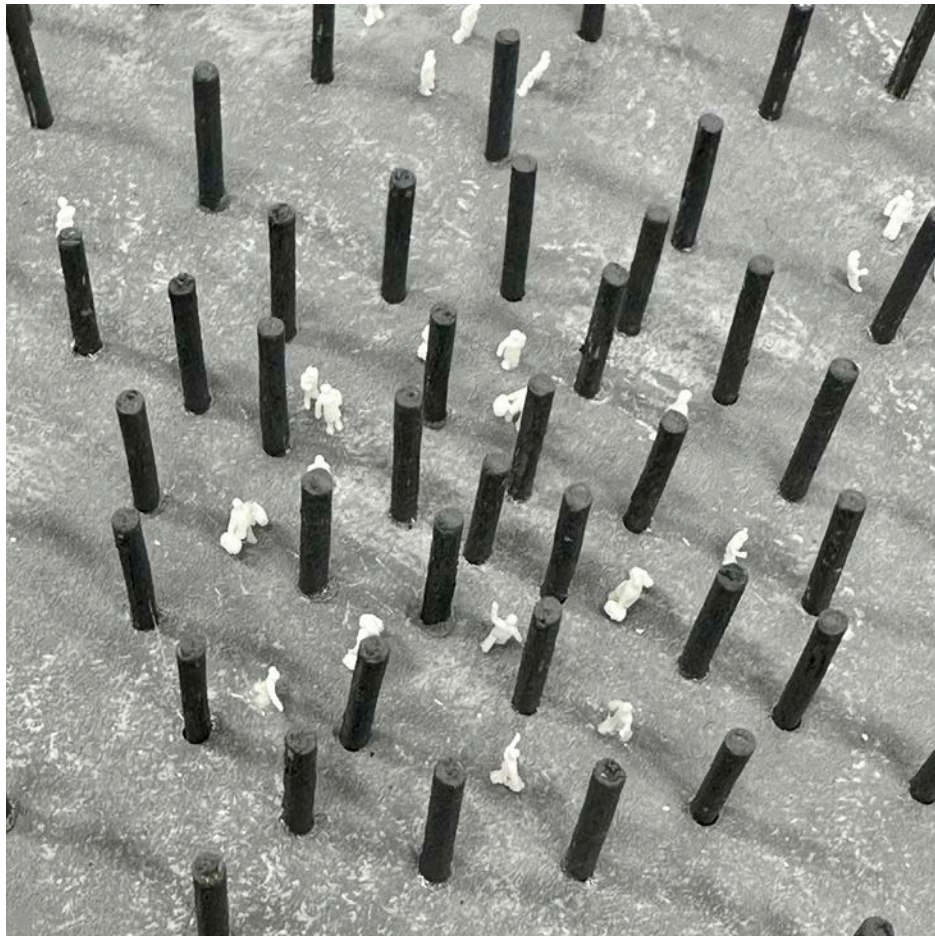

Circular space

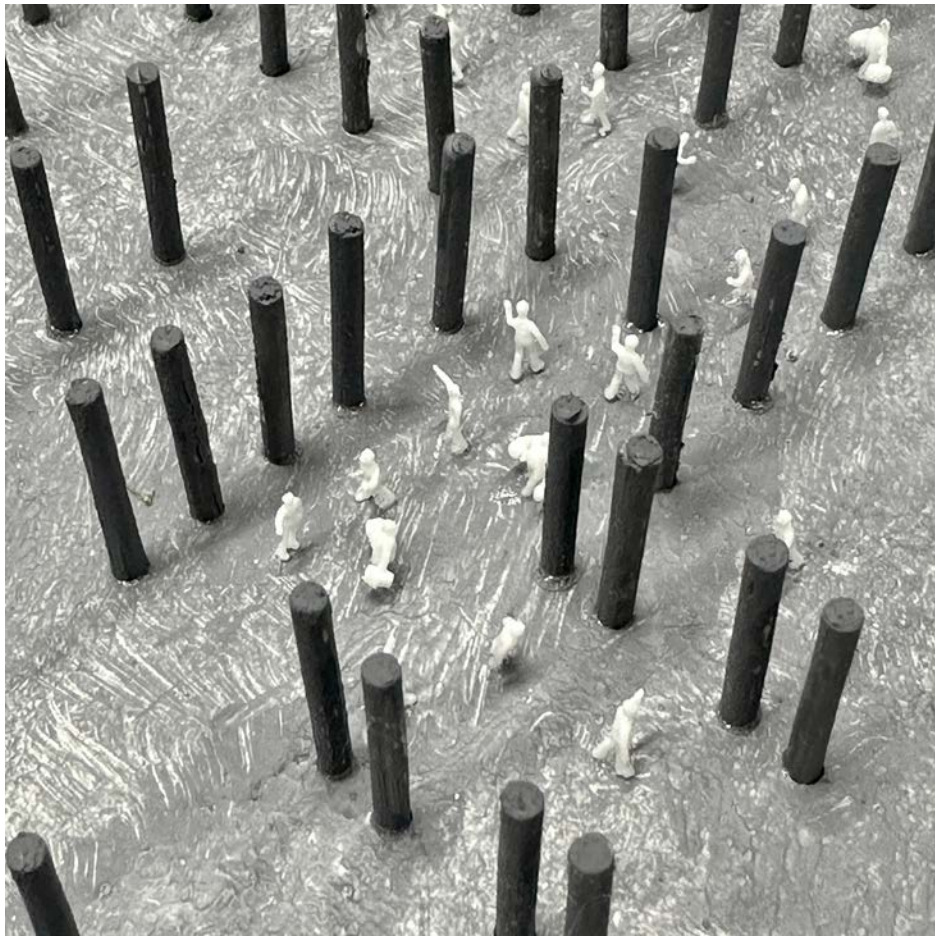

Rectangular space

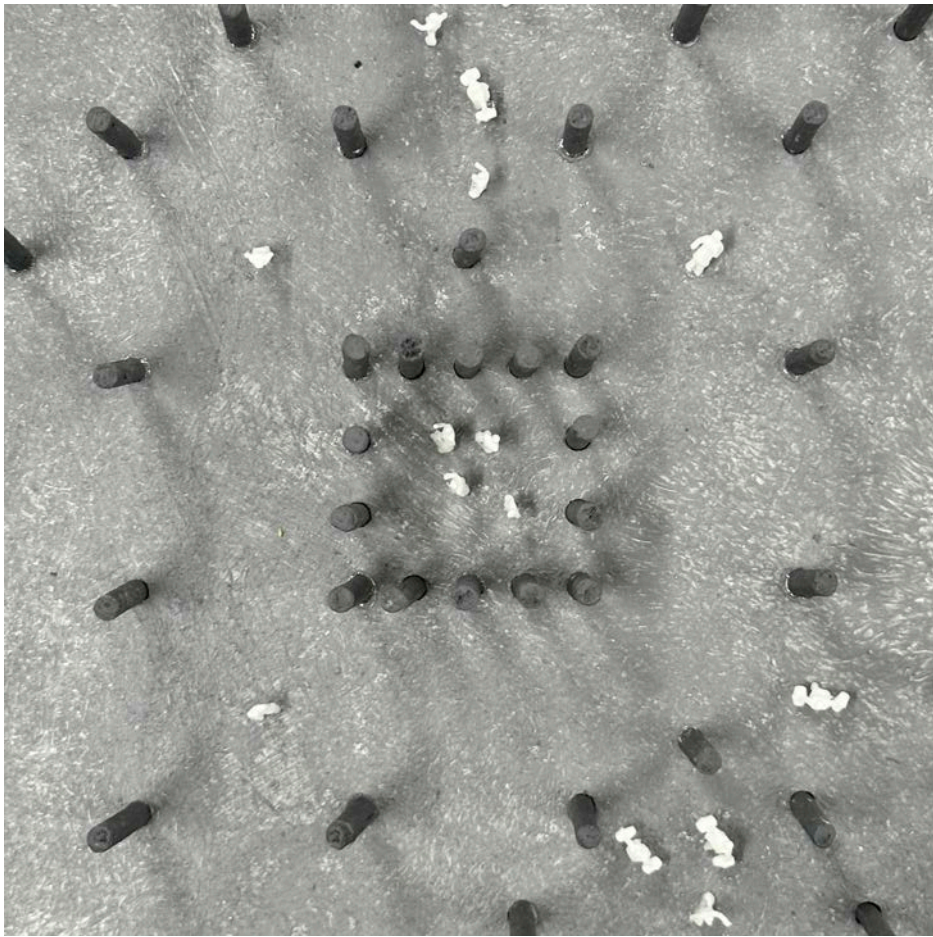

Square space

Concept Model

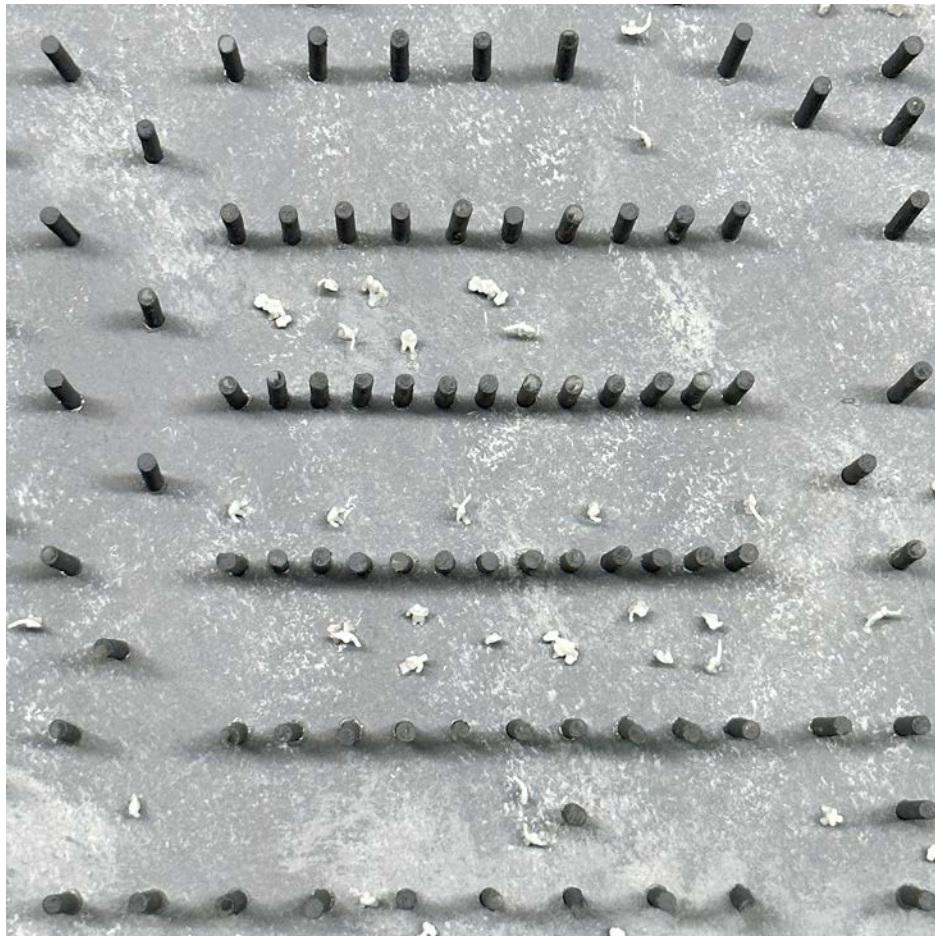

Horizontal space



Diagonal long corridor

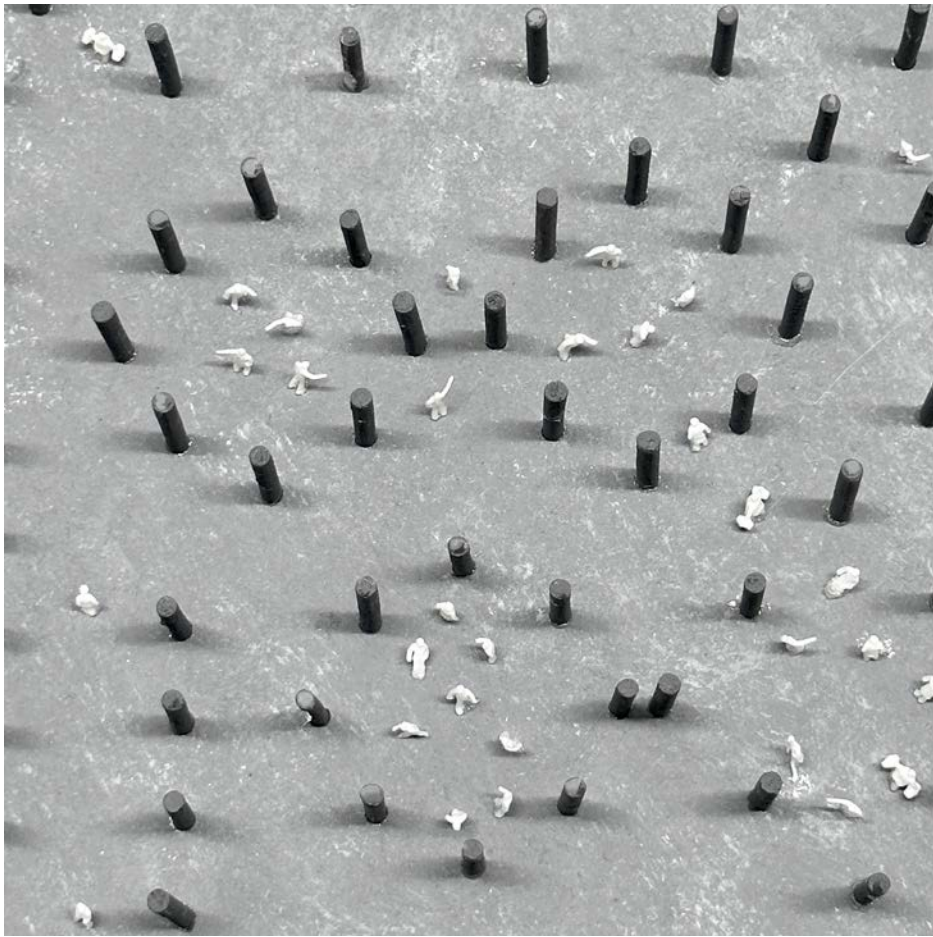

Three seperated circle space

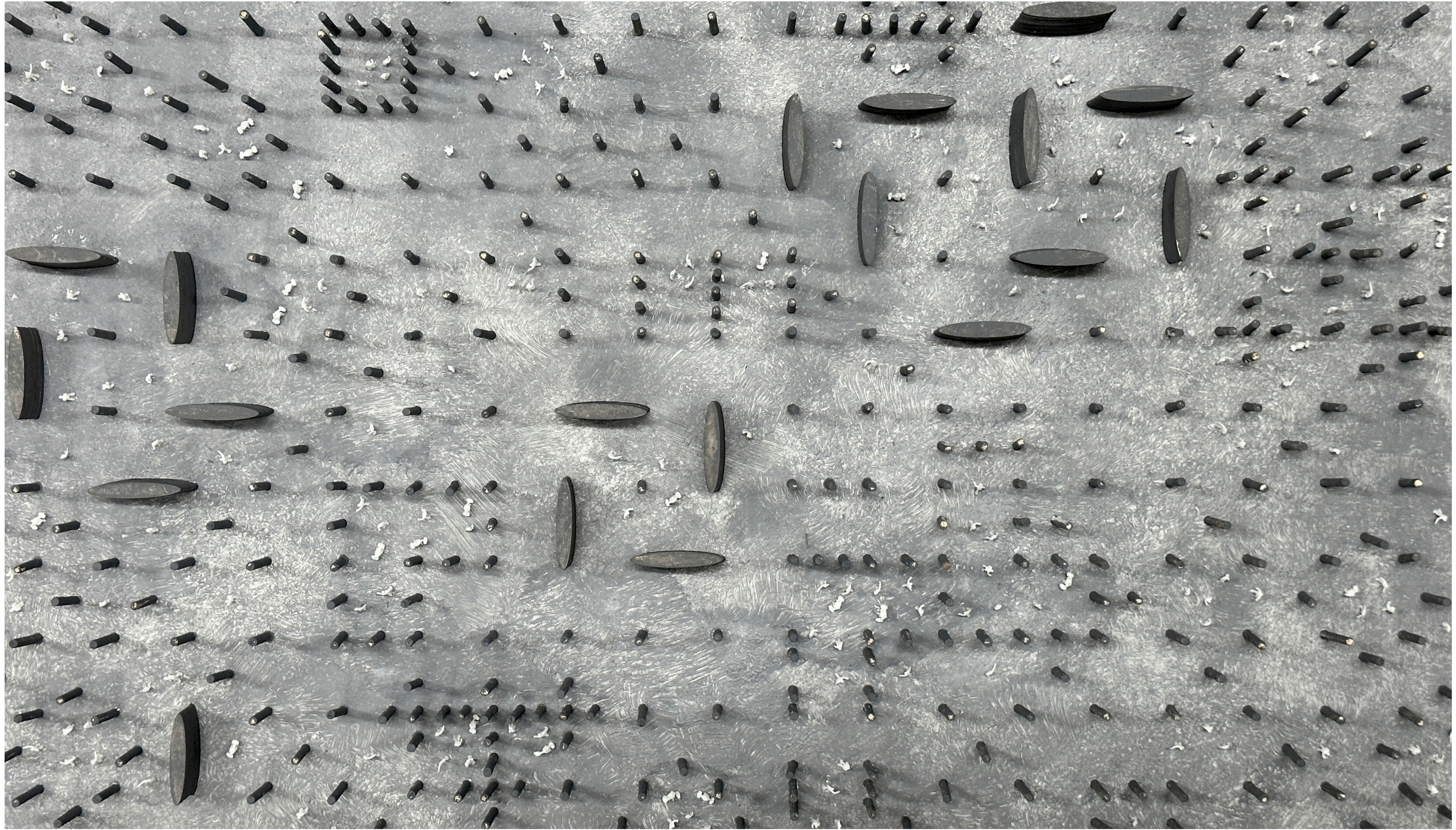

COMBINATIONS...

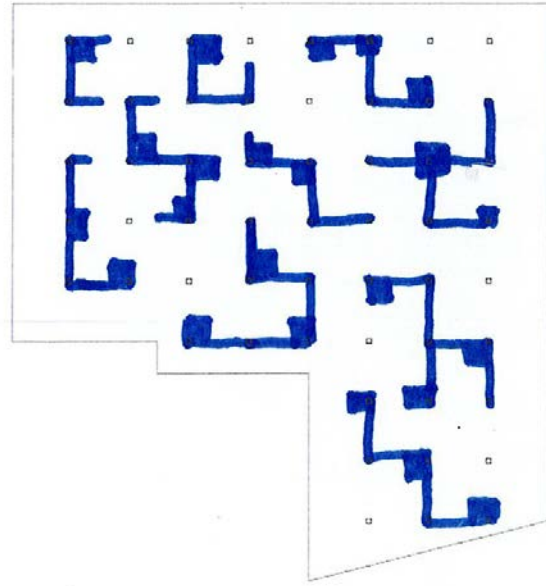

Plan

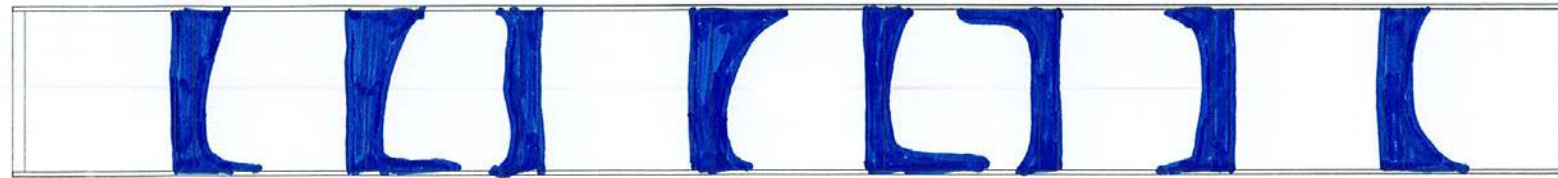

Section



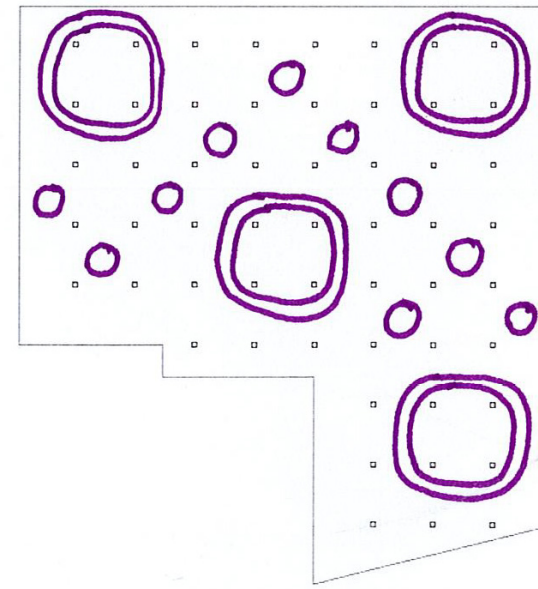
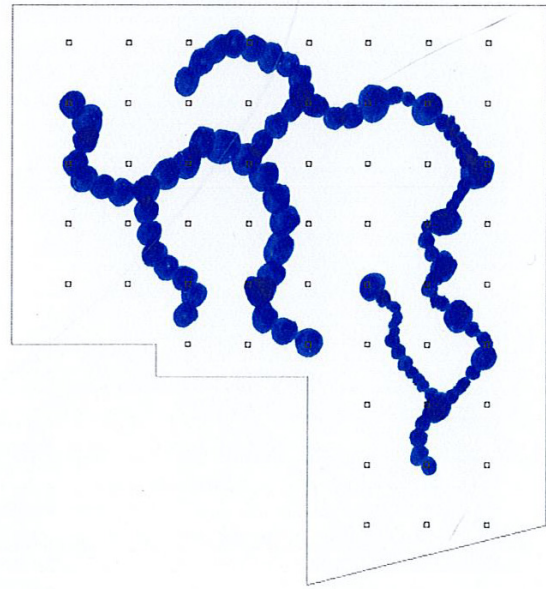

Plan

Openings in Floor

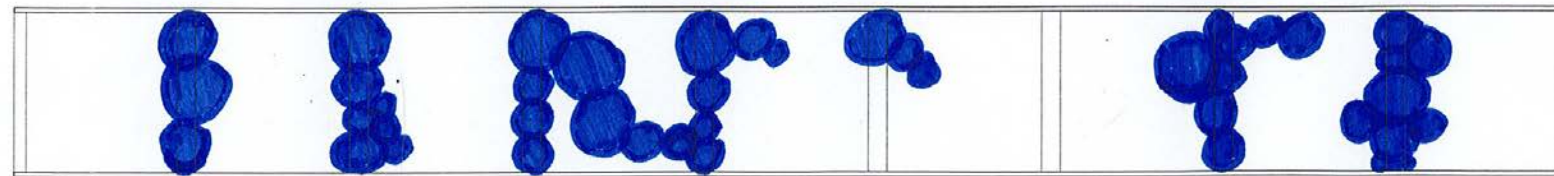

Section

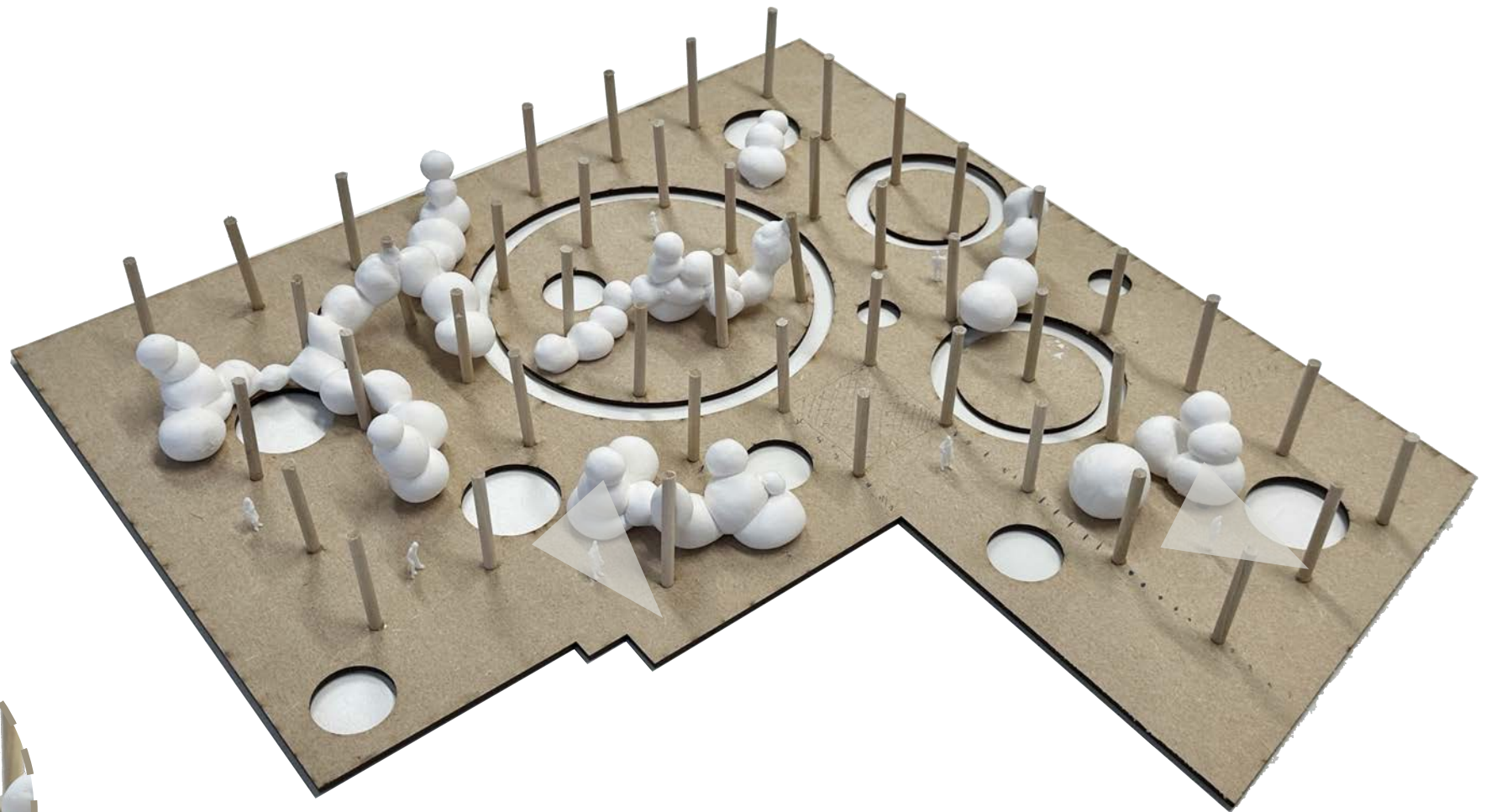

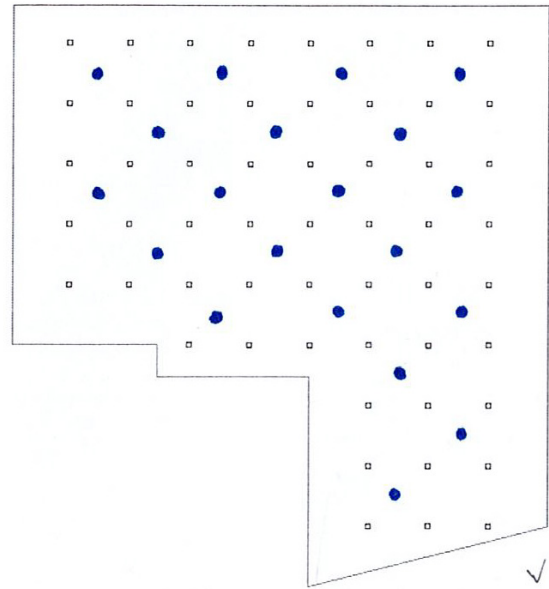

Plan

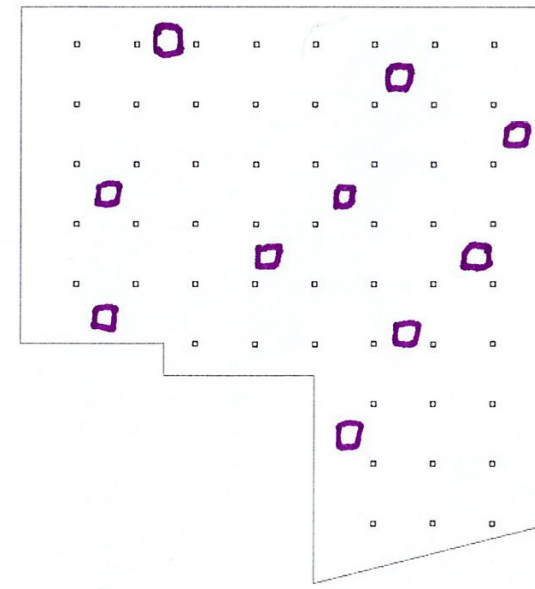

Openings in Floor

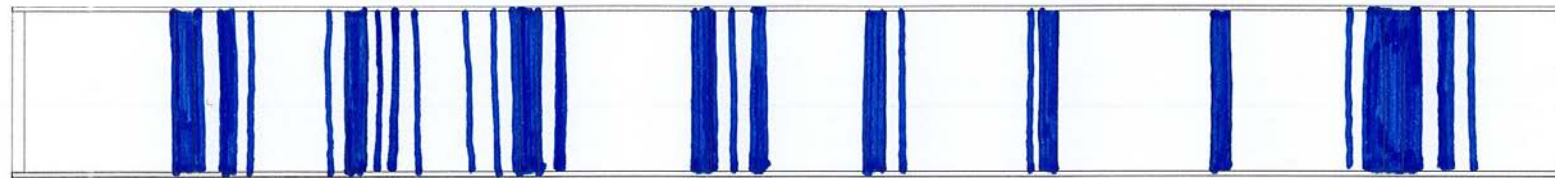

Section

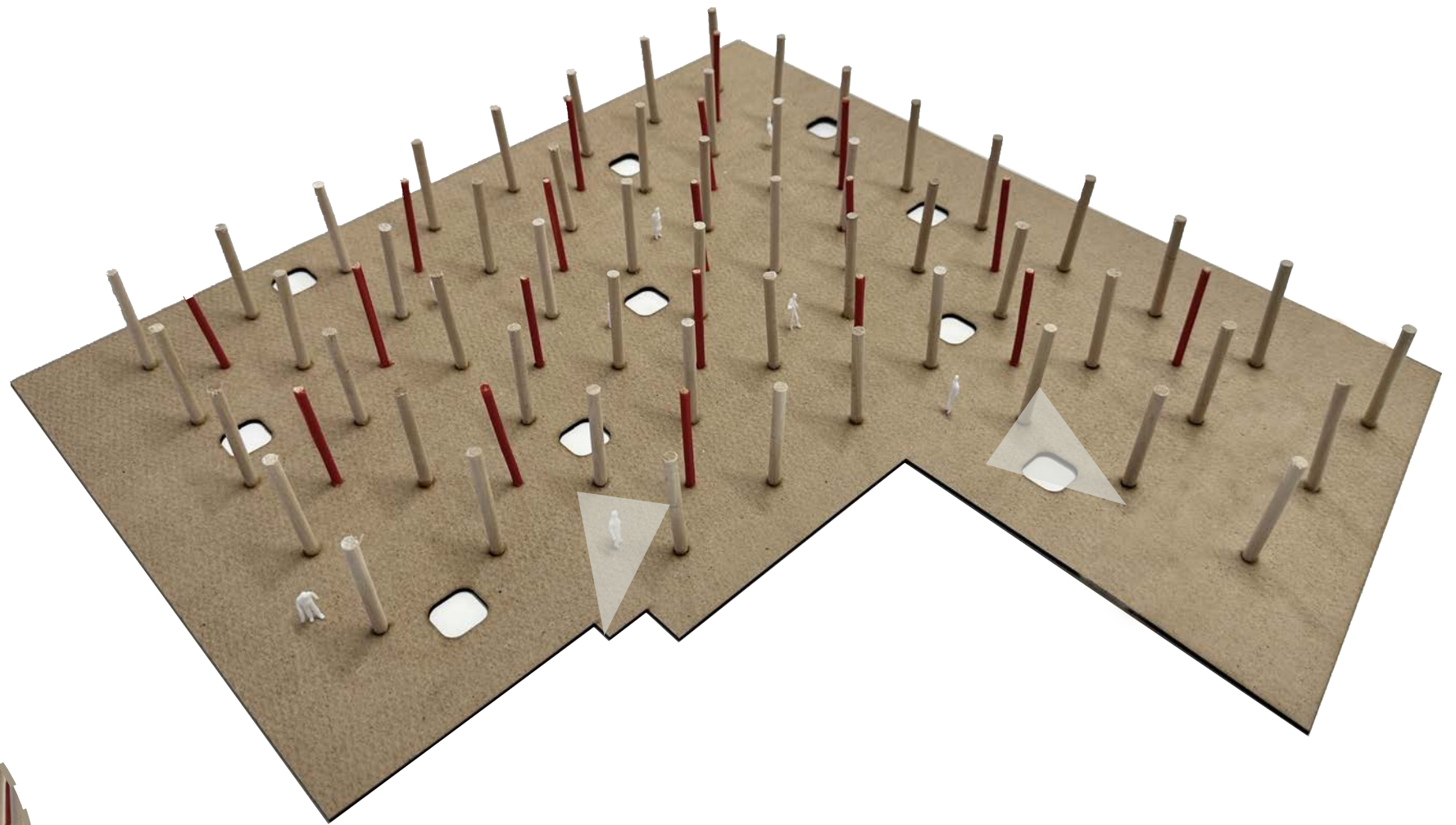

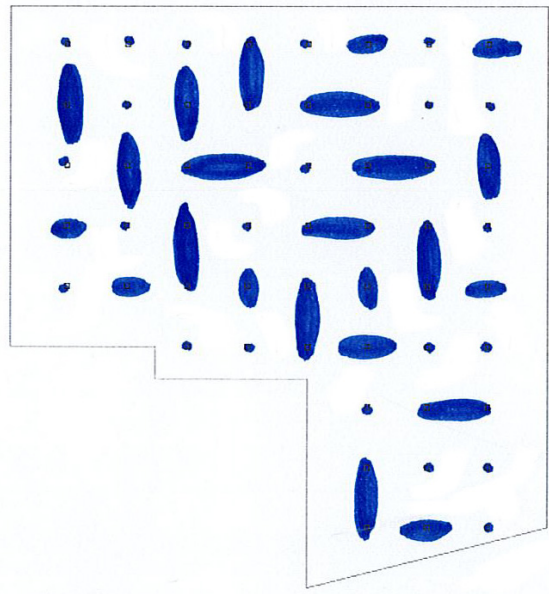

Plan

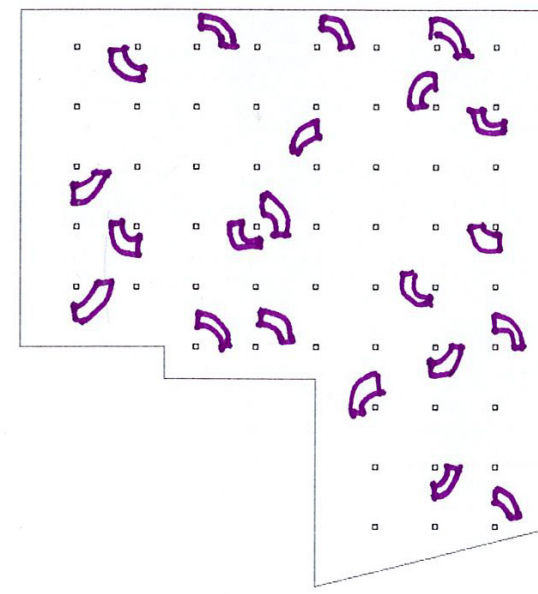

Openings in Floor

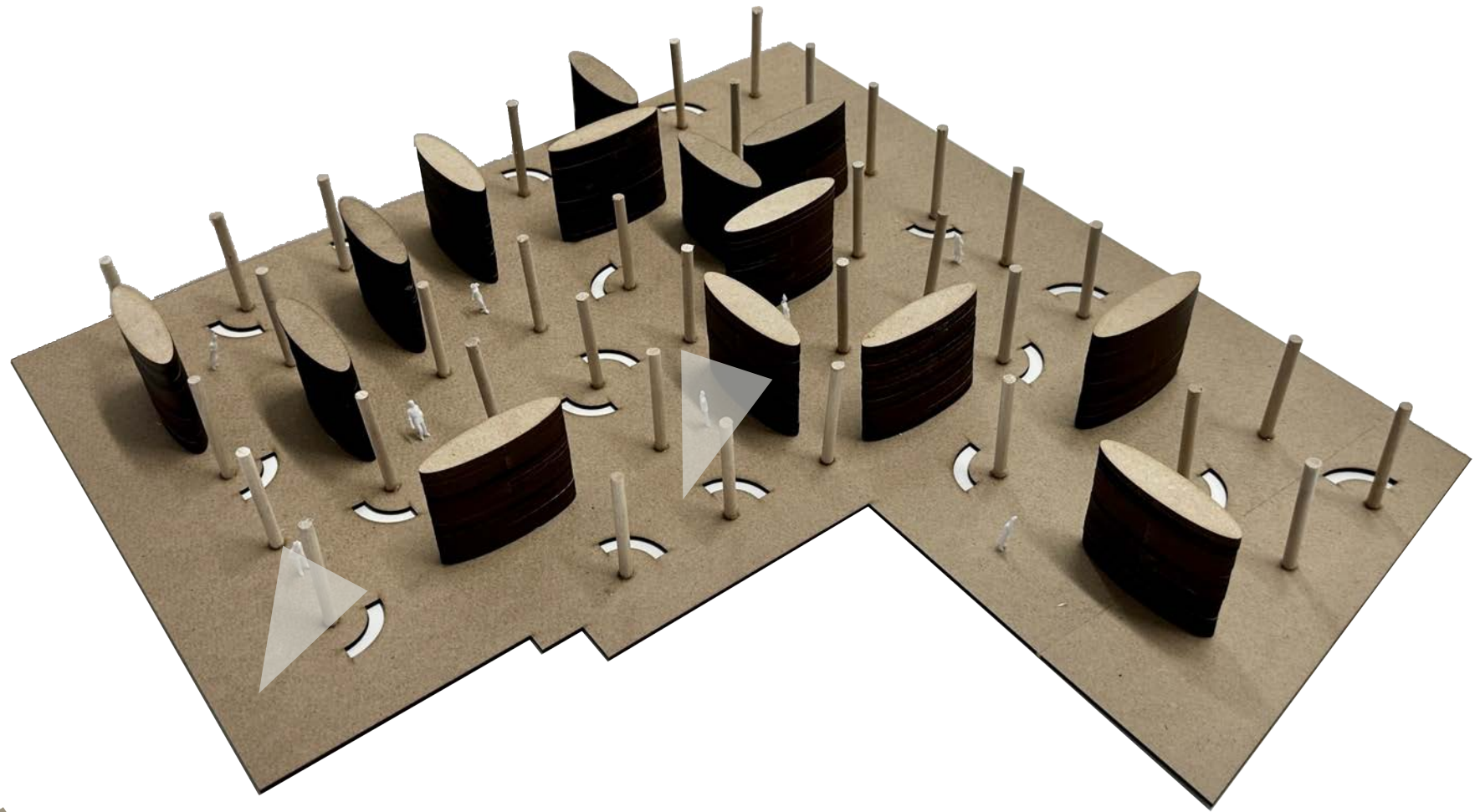



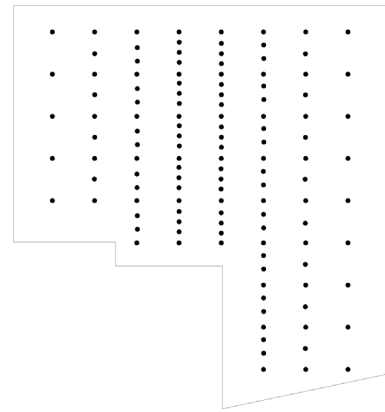
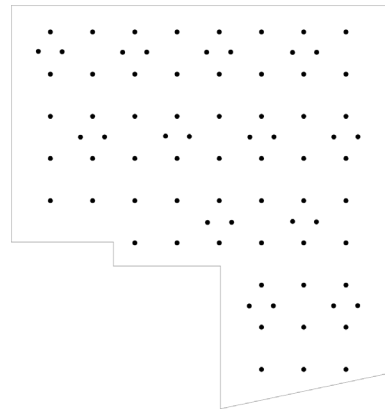
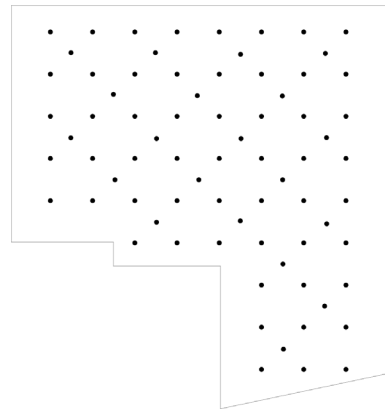
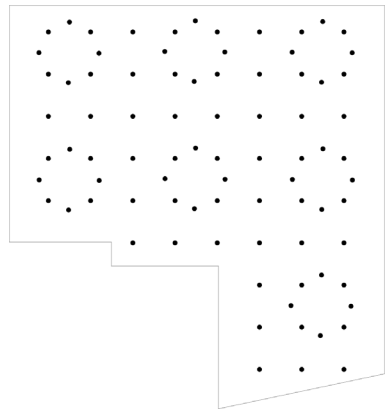

Plan

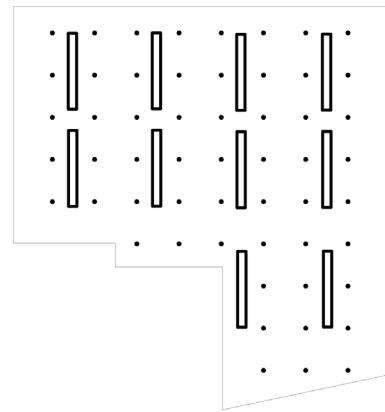
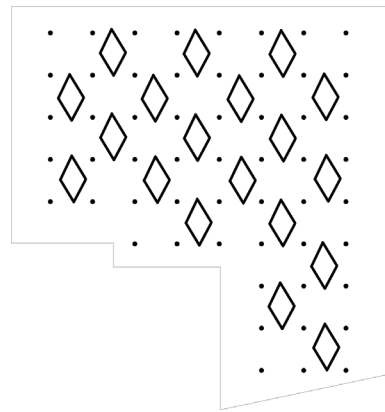
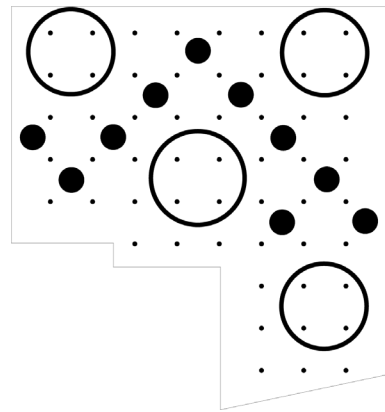

Openings in Floor

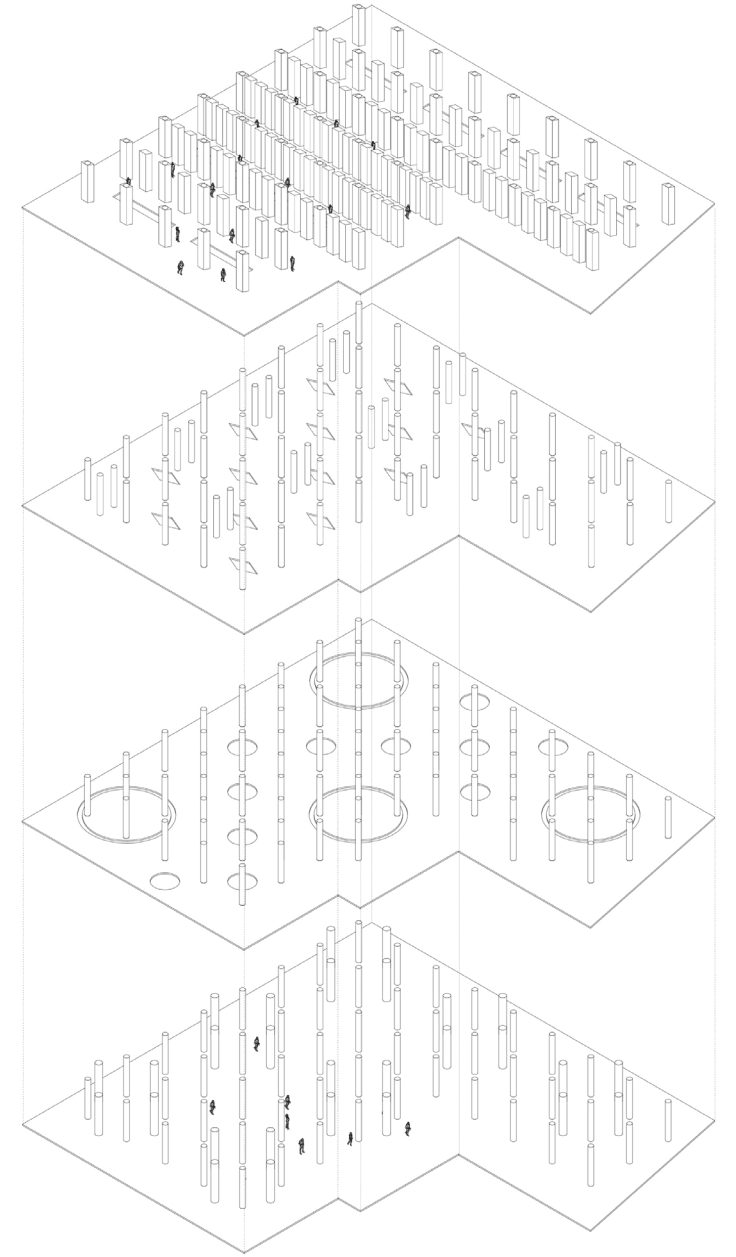

A set of attempts to only add columns

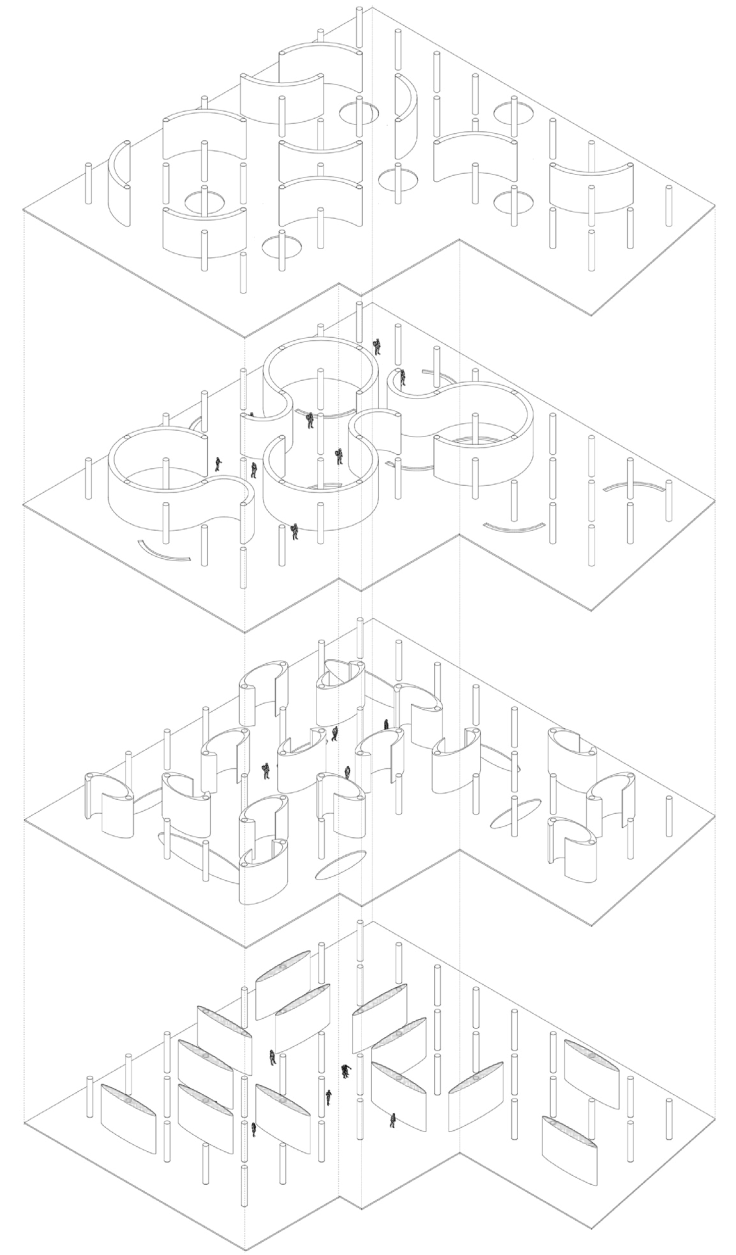
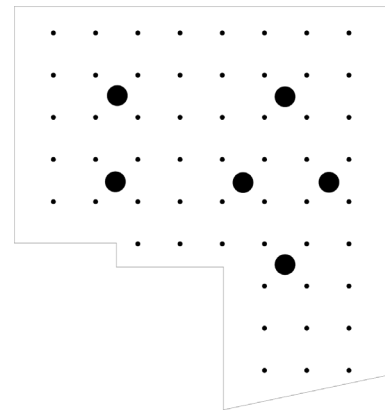
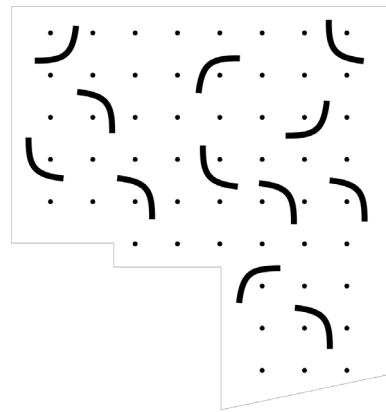
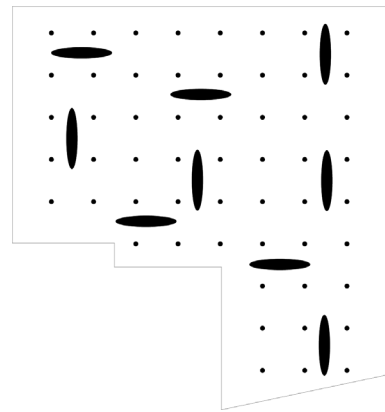
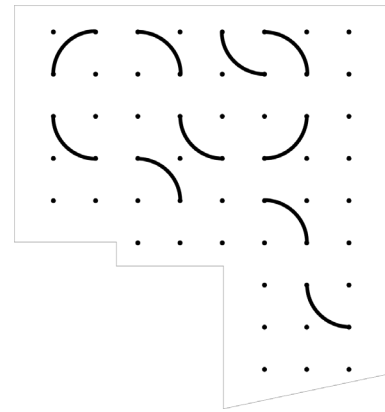
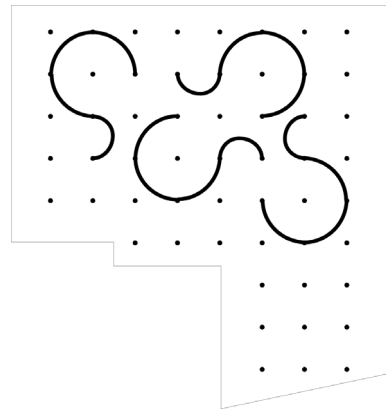
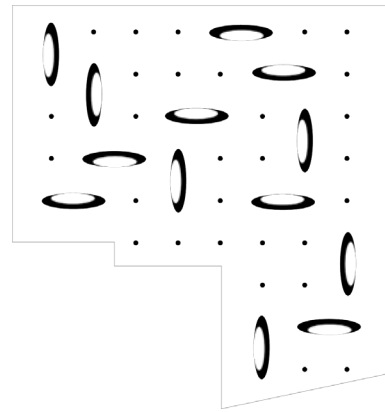
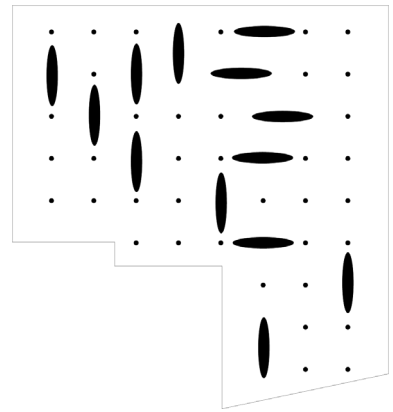

Plan

Openings in Floor

A set of attempts to only change columns shape

III. PROGRAMME

To maximize the use and the character of this building, it can become a contemporary art museum with mainly open space, which is only divided by columns. In the museum, artists can display their art and have a unique spatial experience.

Contemporary Art Museum: Zoning Diagram

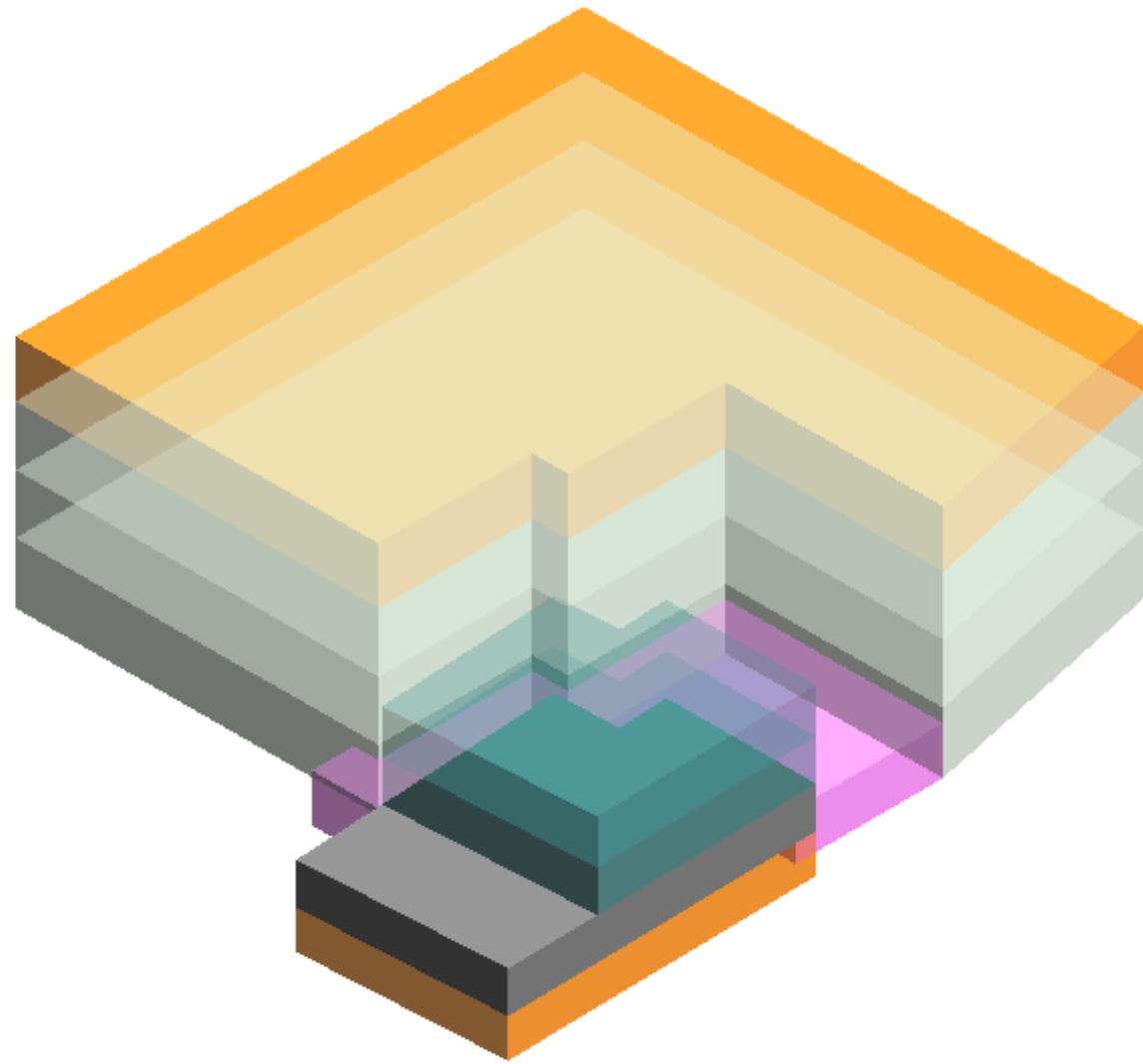

- Exhibition
- Public Area
- Offices
- Entry
- Museum Loading & Technical Zone

IV. PROPOSAL

Every floor has a different column layout to create a different spatial experience for the exhibitions.

Final Columns Layout

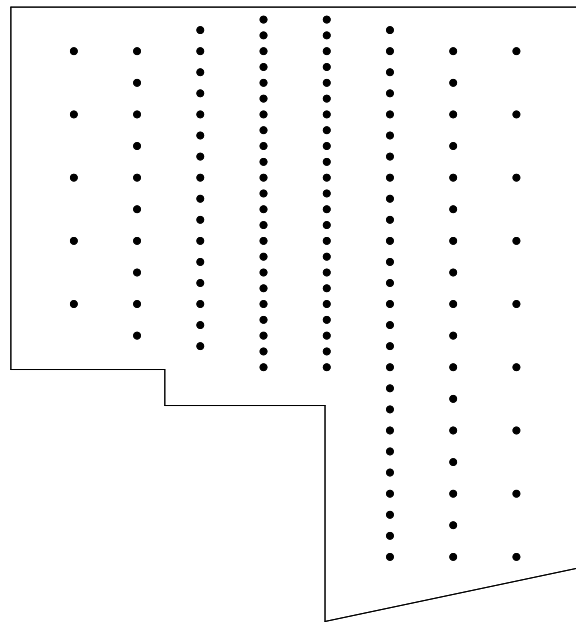

Ground Floor

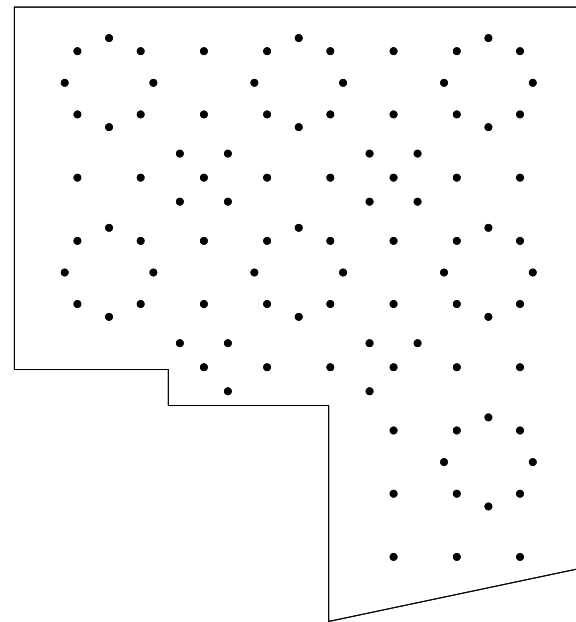

First Floor

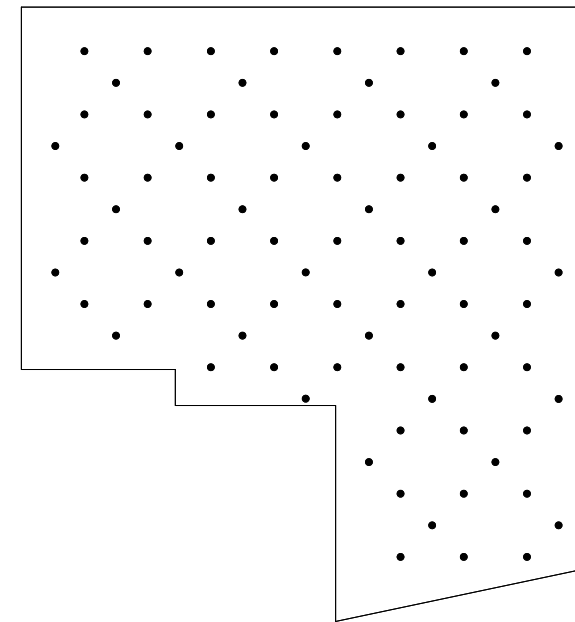

Second Floor

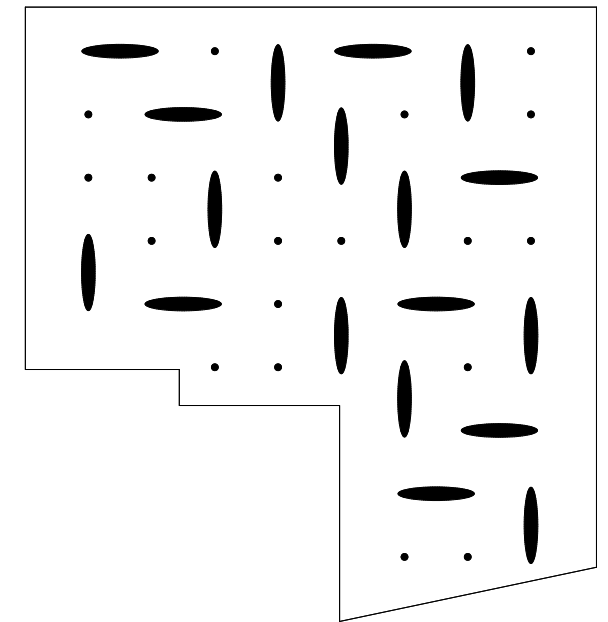

Third Floor

Ground Floor Columns Development

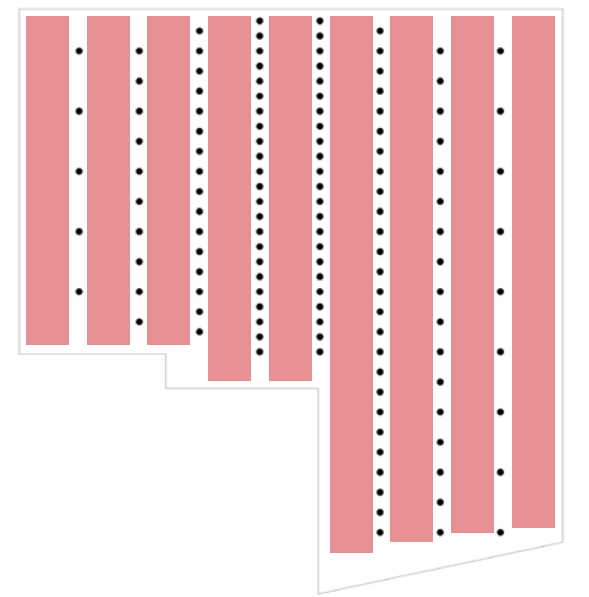
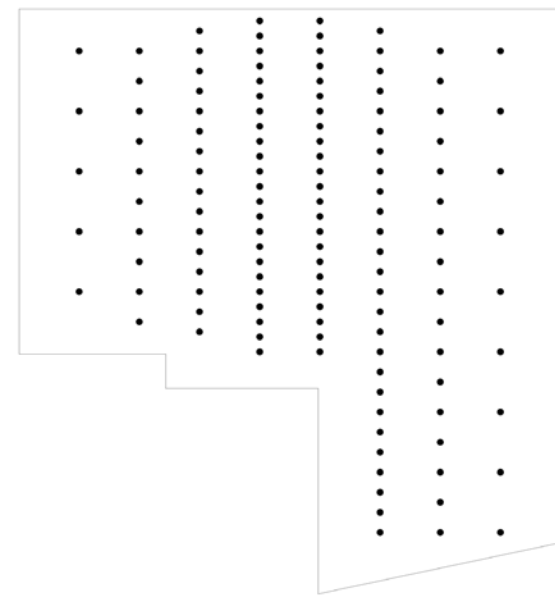
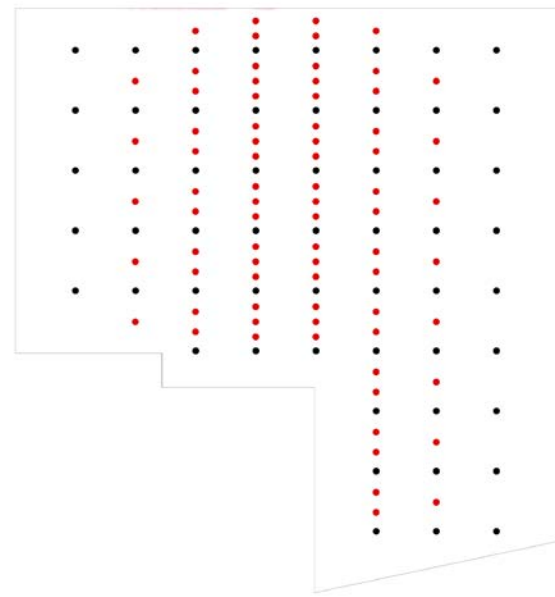
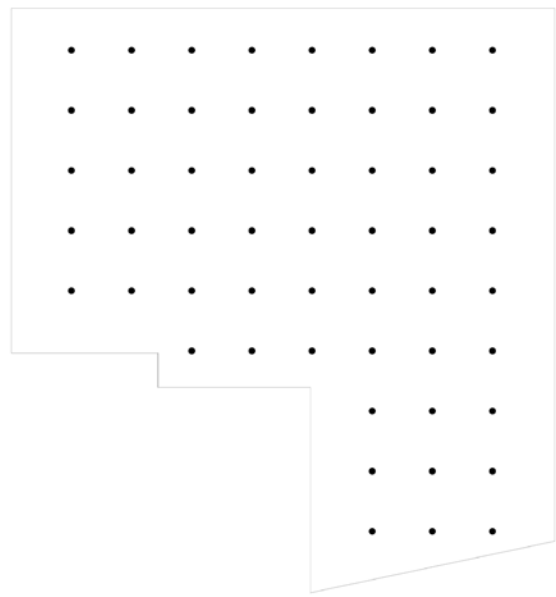

The number of columns change vertically, gradually increasing and then returning to the original state. In this arrangement, the space is divided into vertical strips by columns.

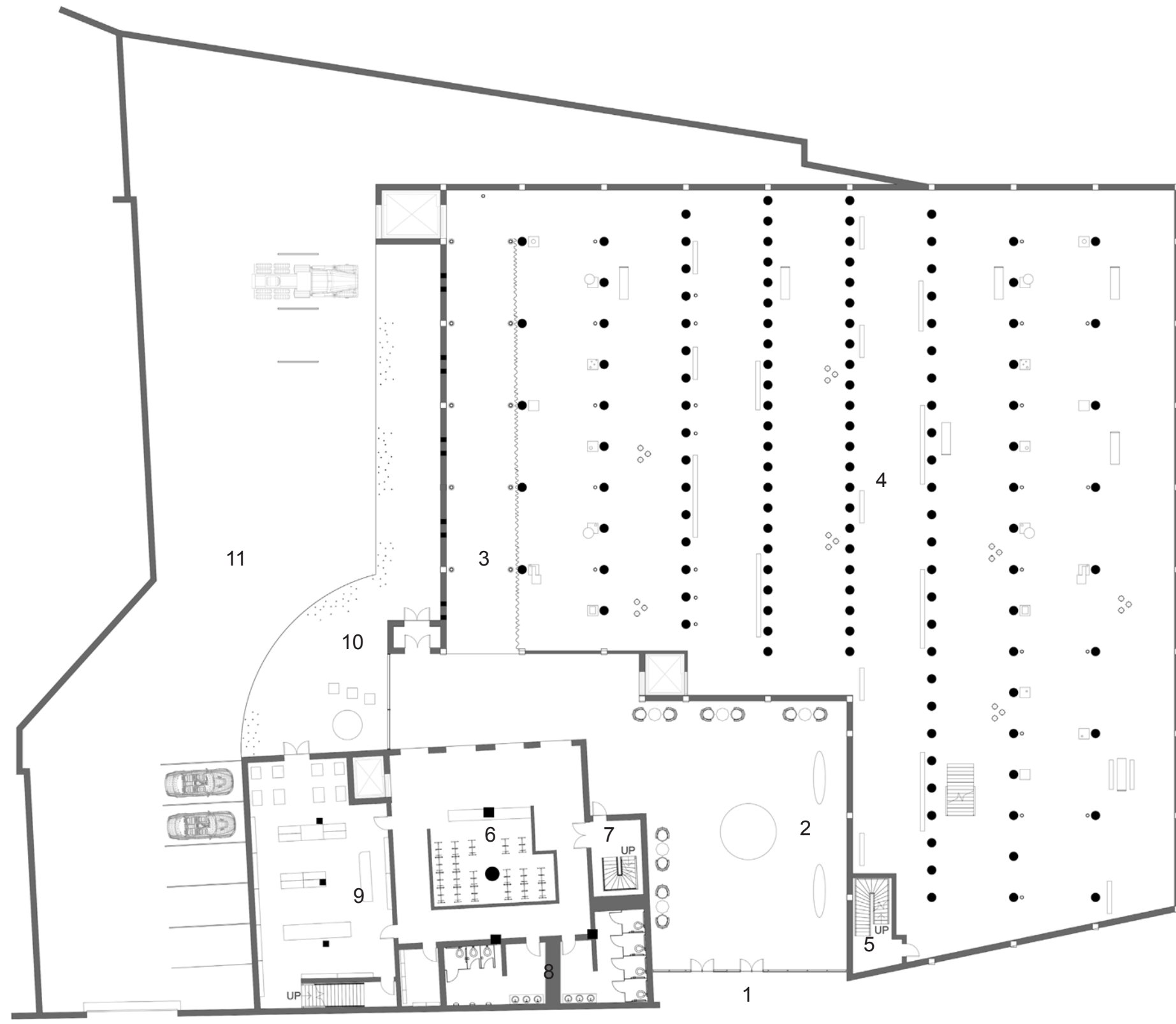

- 1. Entry
- 2. Information center
- 3. Exhibit entry
- 4. Exhibit hall
- 5. Stair
- 6. Cloak room
- 7. Stair
- 8. WC
- 9. Shop
- 10. Corridor
- 11. Parking

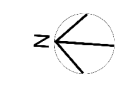
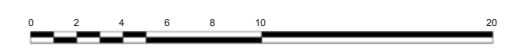

GF floor plan

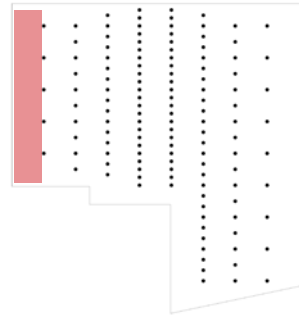
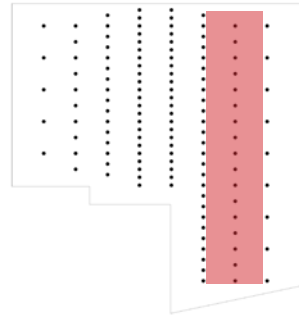

Exhibit Entry



Corridor | Exhibit Room

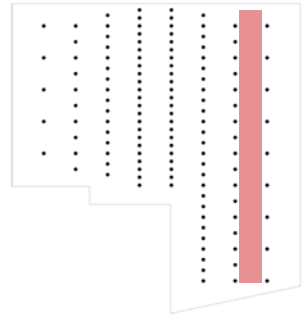
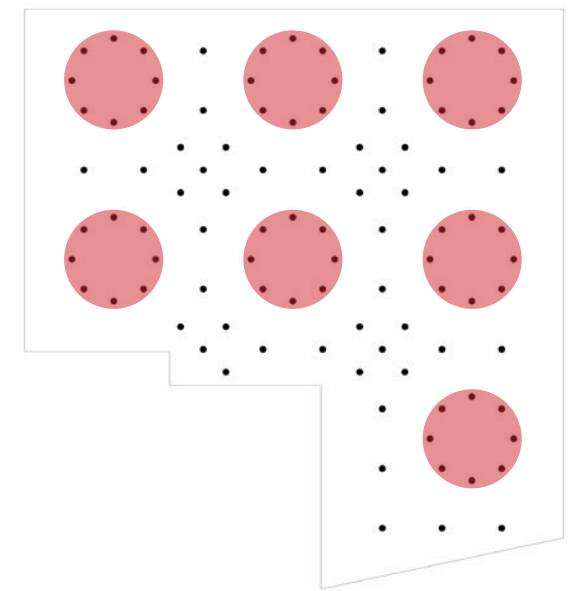
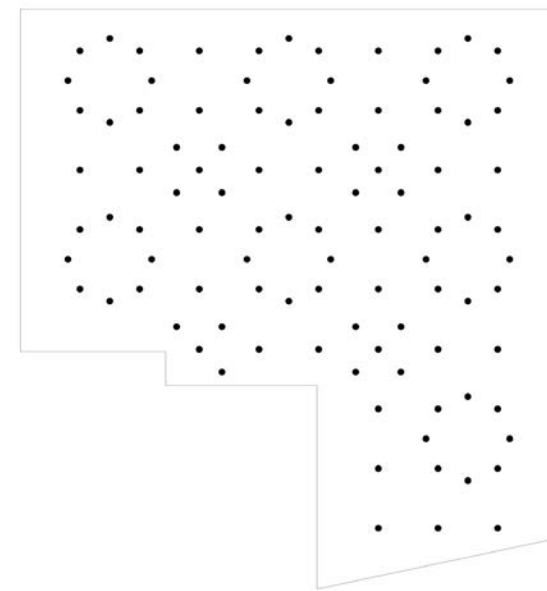
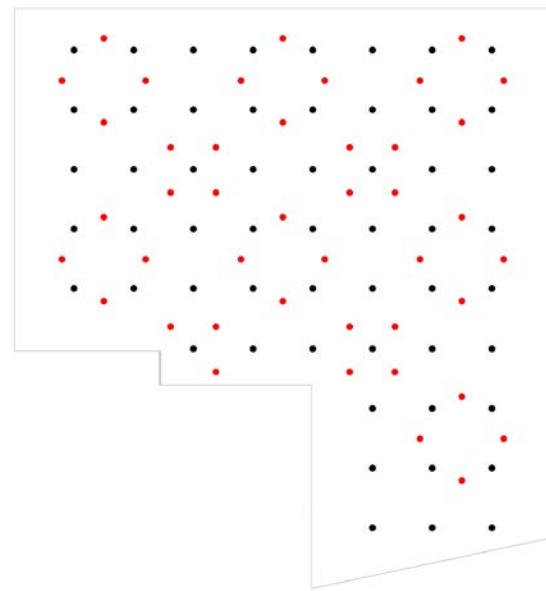
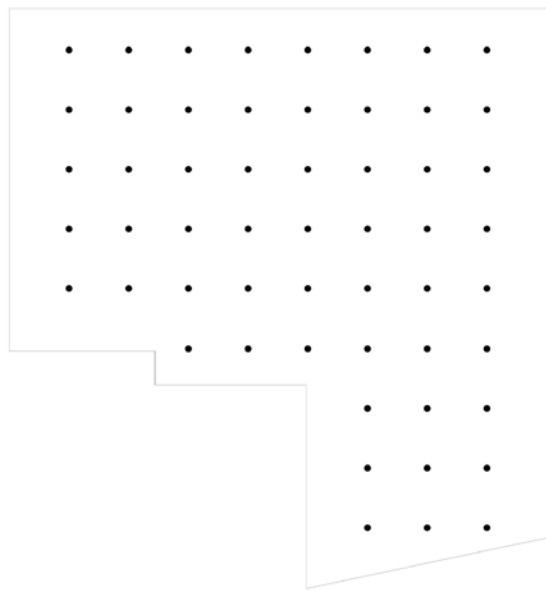
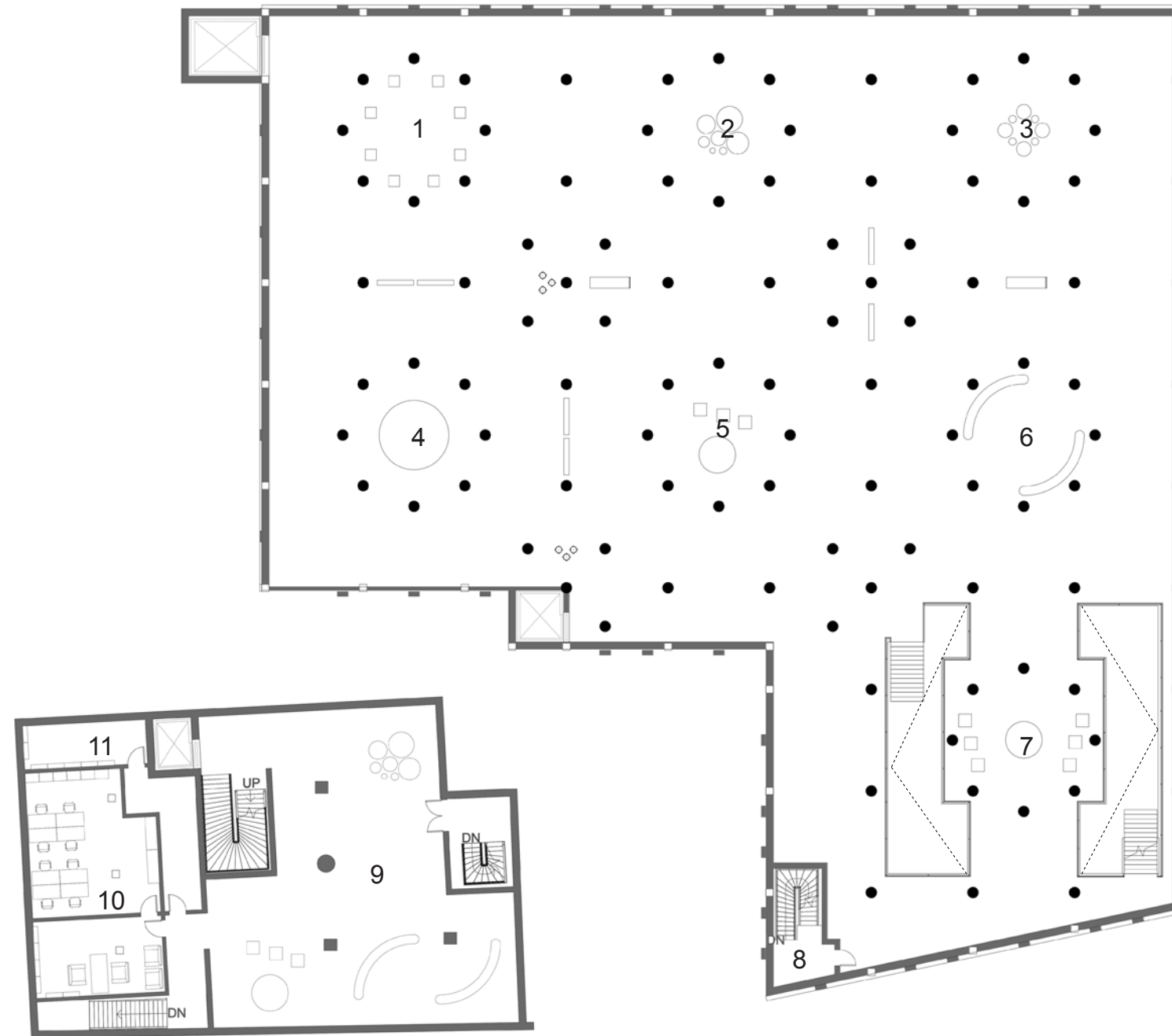

Exhibit Room

First Floor Columns Development



Added a column on top, bottom, left, and right of a unit, transforming the space from a square to a circle.



- 1-7: Exhibit room 1-7
- 8: Stair
- 9: Exhibit hall (ending)
- 10: Office
- 11: Storage

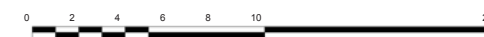

1F floor plan

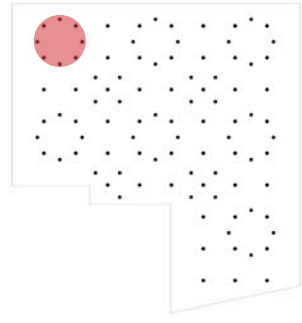

Exhibit Room

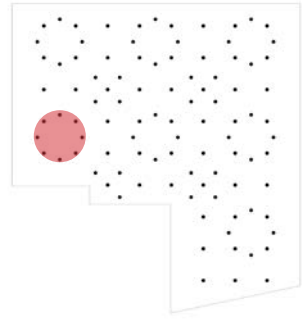
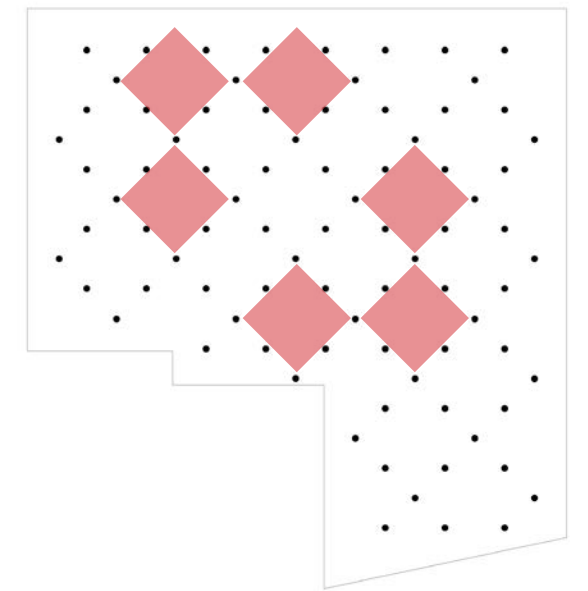
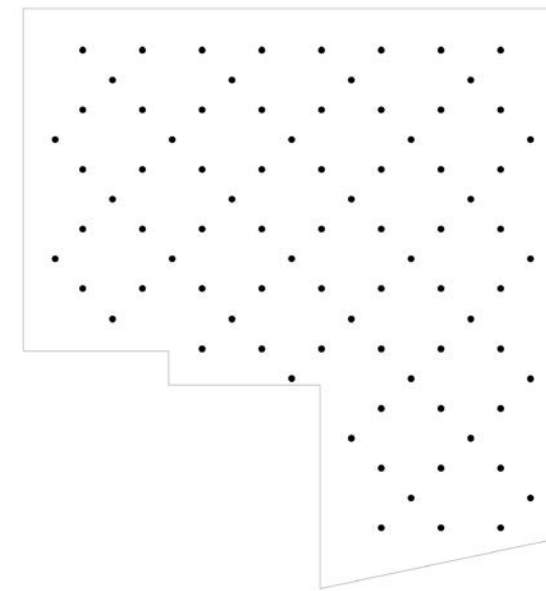
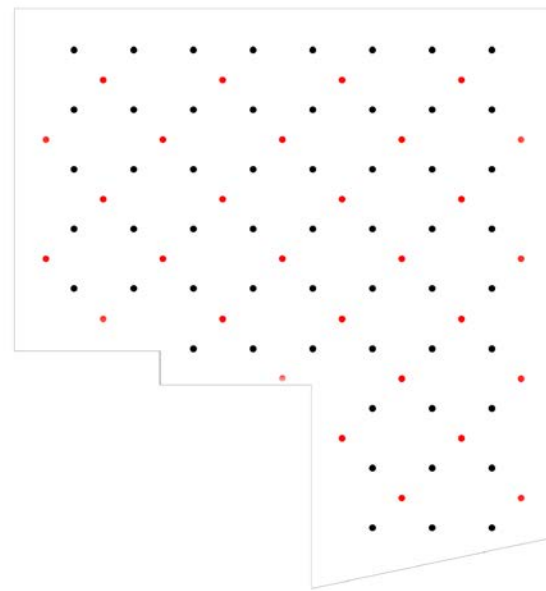
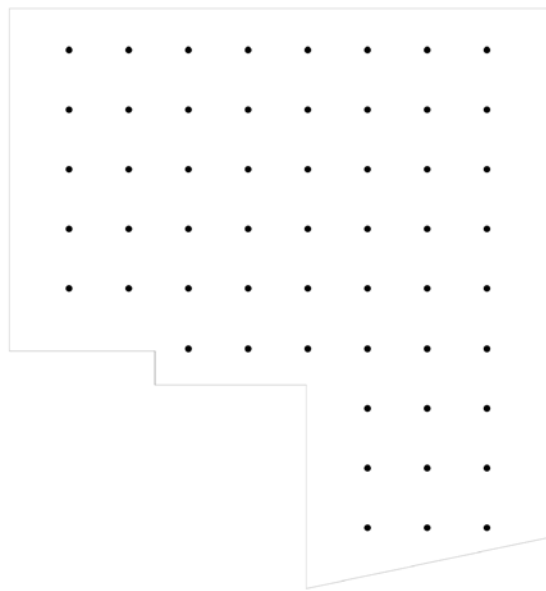

Exhibit Room | Corridor

Second Floor Columns Development



Added a column in the middle of the unit and rotated the original grid system 45 degrees. It creates a larger square space.



- 1: Temporary exhibit room
- 2: WC
- 3-7: Exhibit room
- 8: Stair
- 9: Conference room
- 10: Office

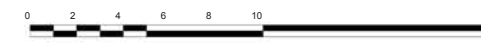

2F floor plan

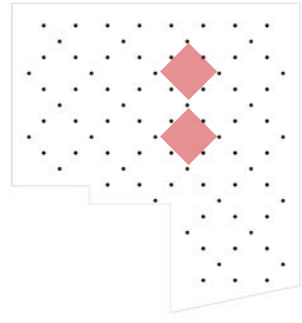

Exhibit Room | Rest Area

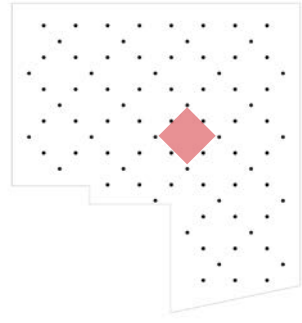
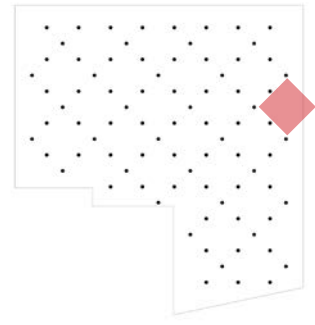
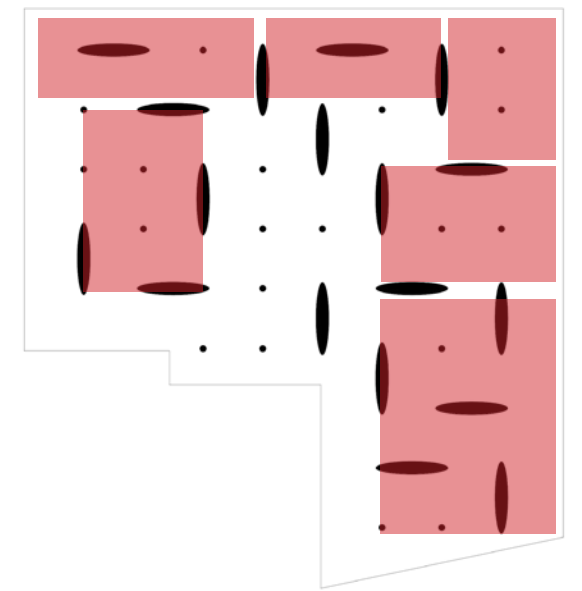
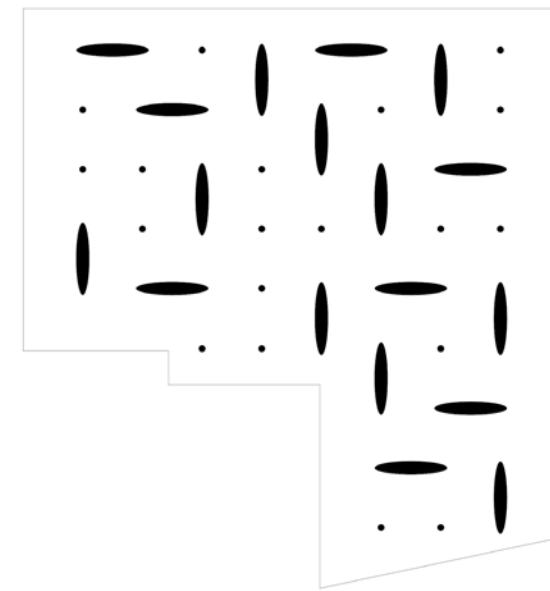
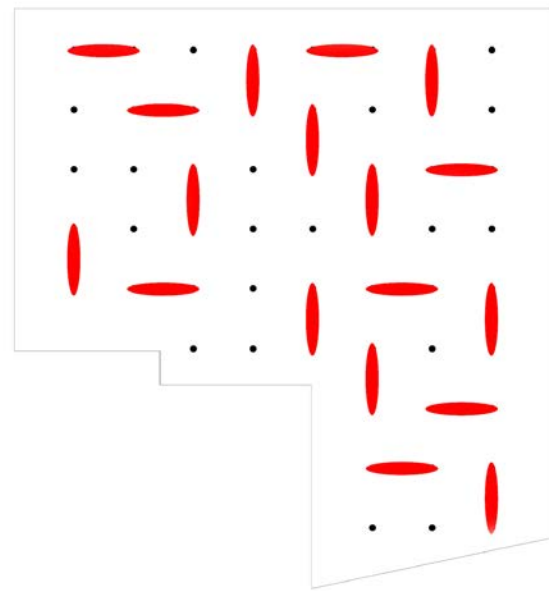
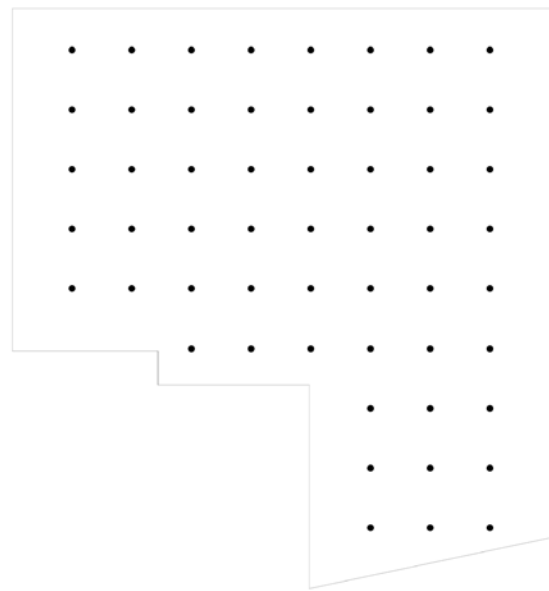

Exhibit Room



Corner Exhibit Room

Third Floor Columns Development



A layout with changing the shape and combining two columns. The space is divided by those massive pieces.

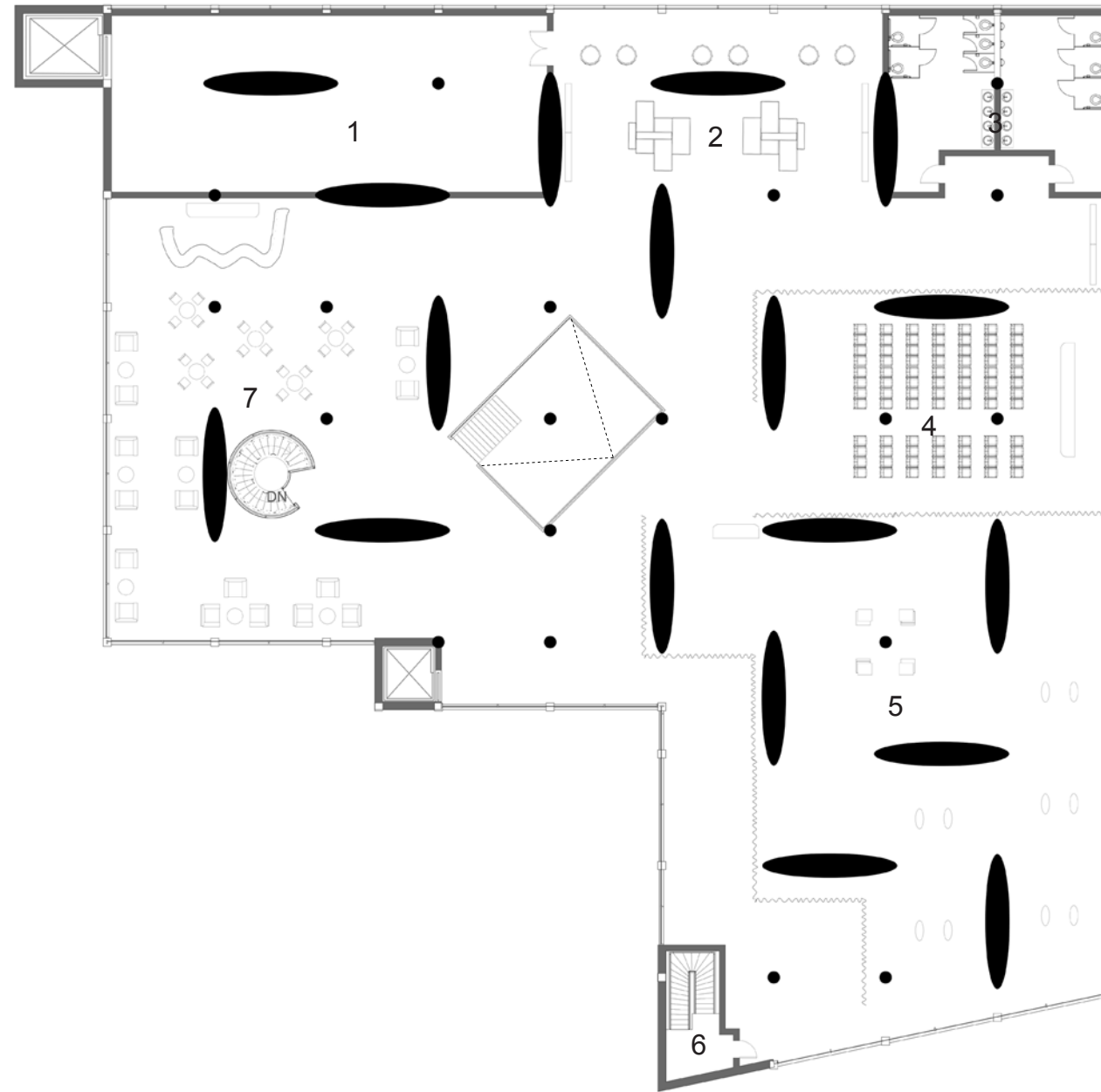

- 1: Artwork storage
- 2: Library
- 3: WC
- 4: Lecture theater
- 5: Temporary exhibit
- 6: Stair
- 7: Cafe



3F floor plan

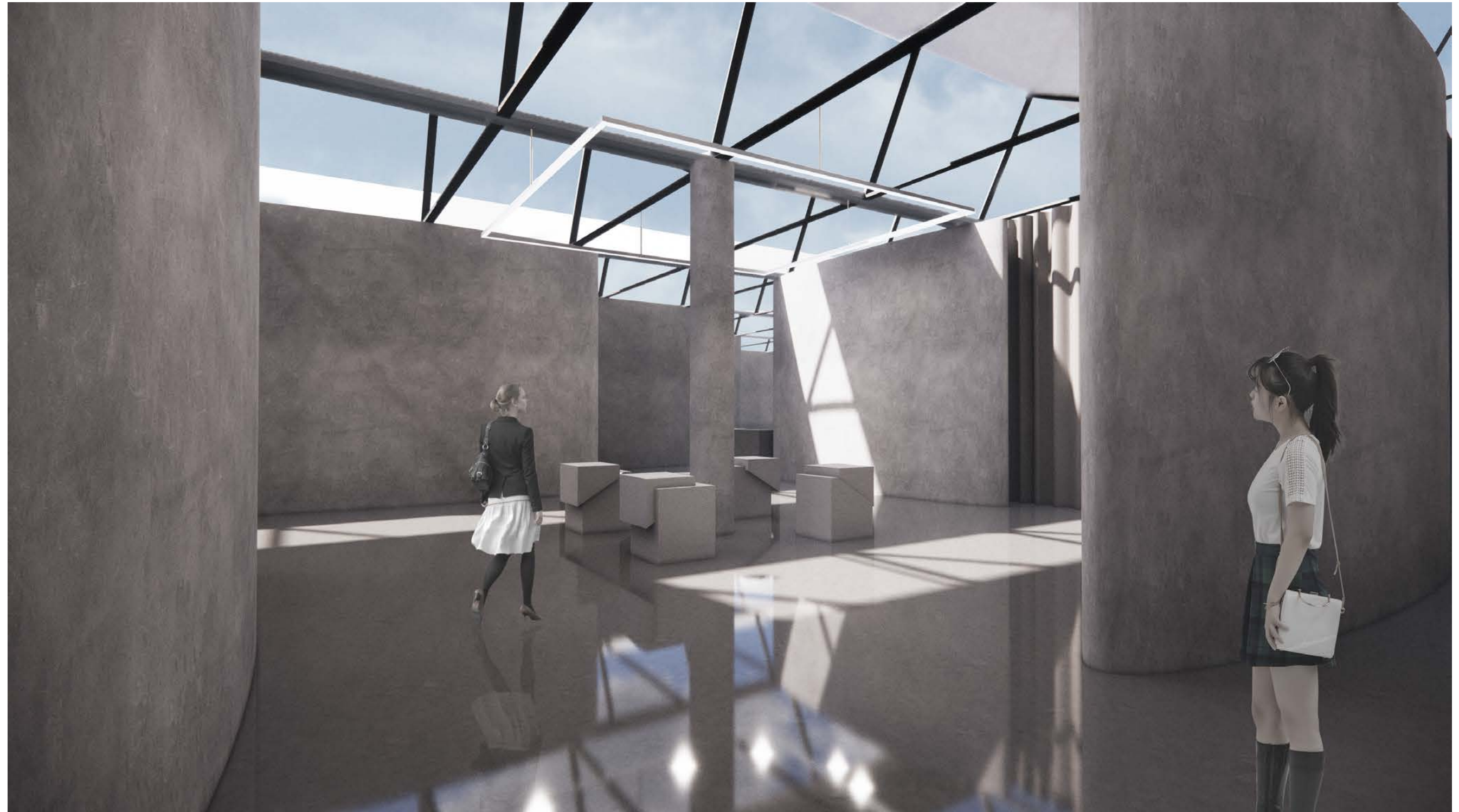
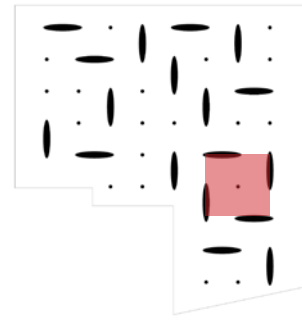

Temporary Exhibit Room

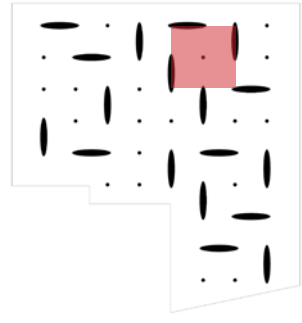

Library

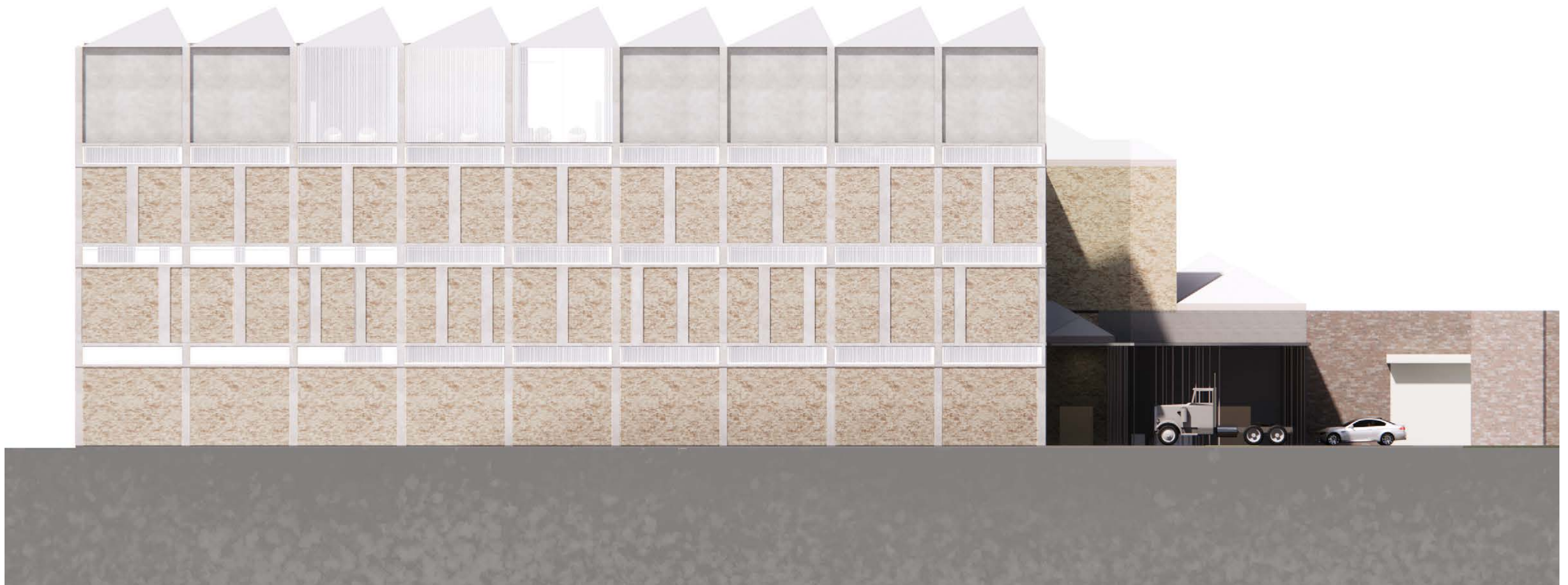

Elevation | Facade

Materiality | Lighting | Plinth

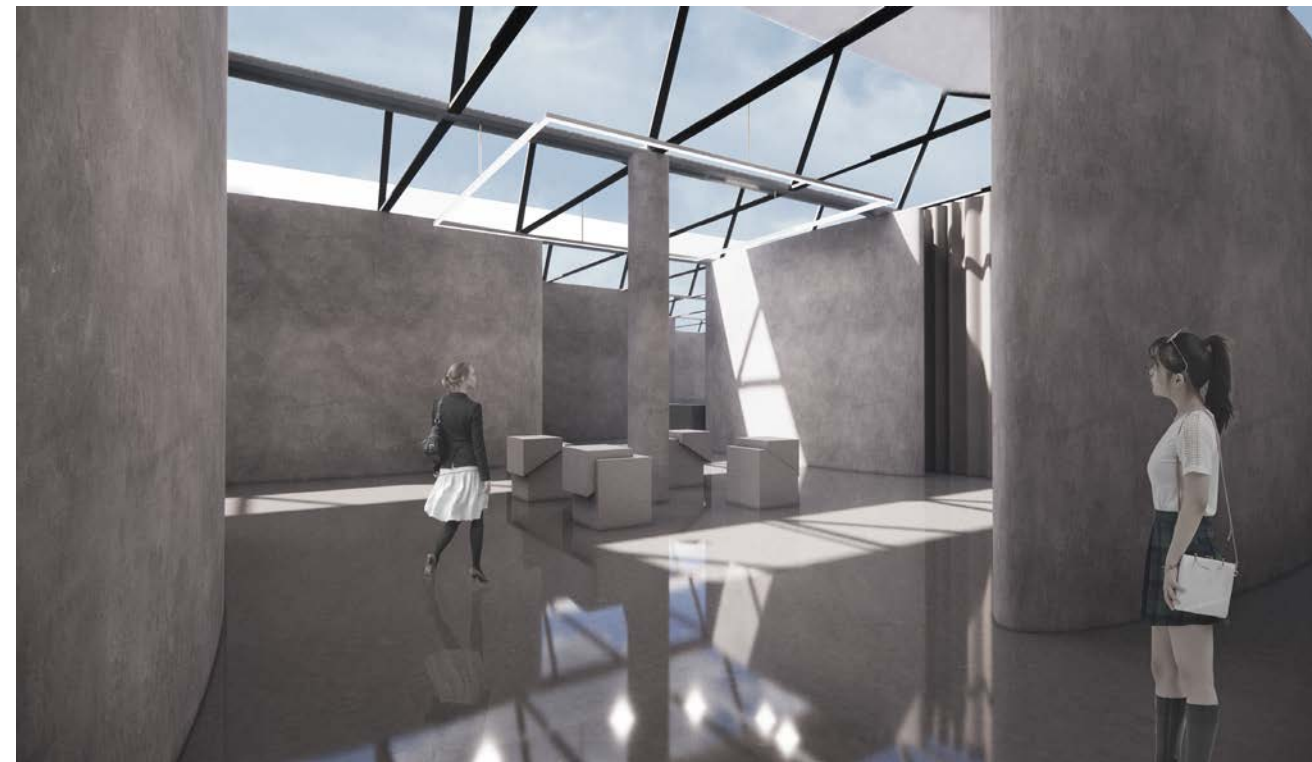

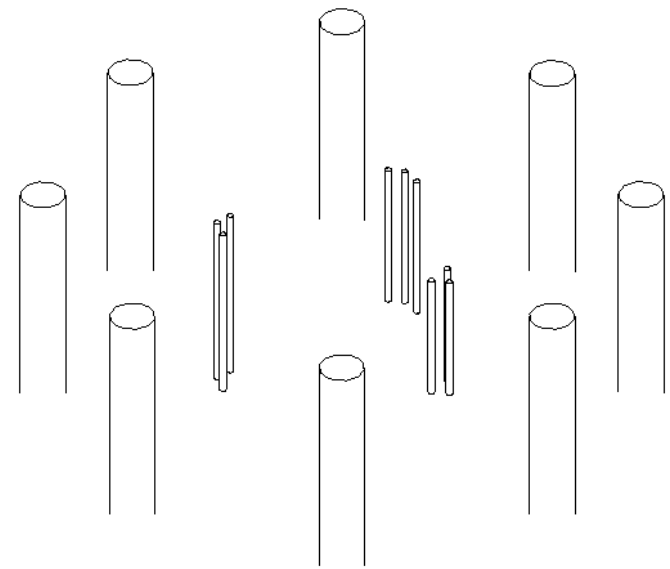
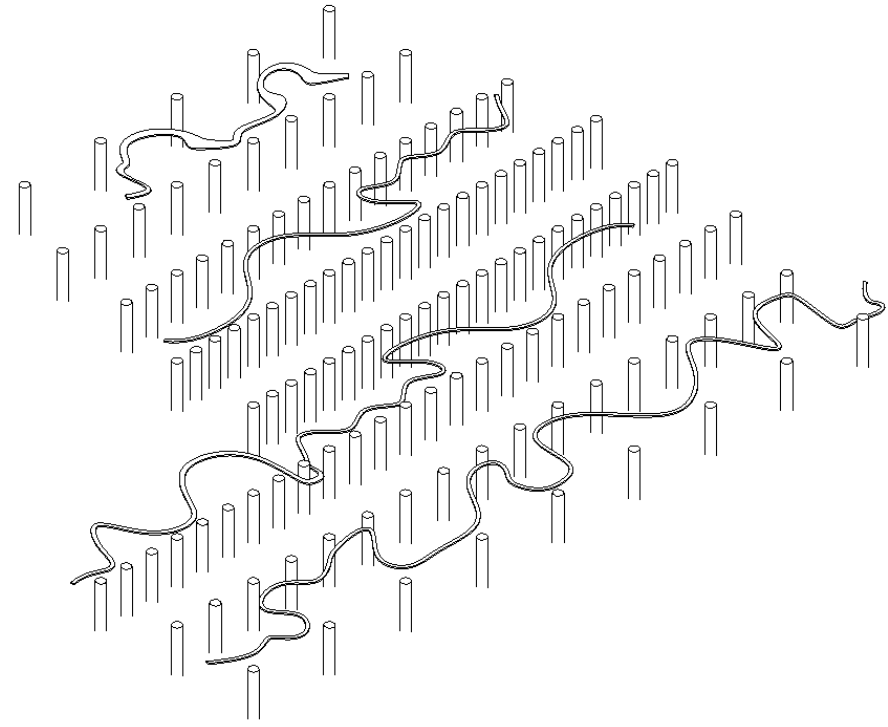

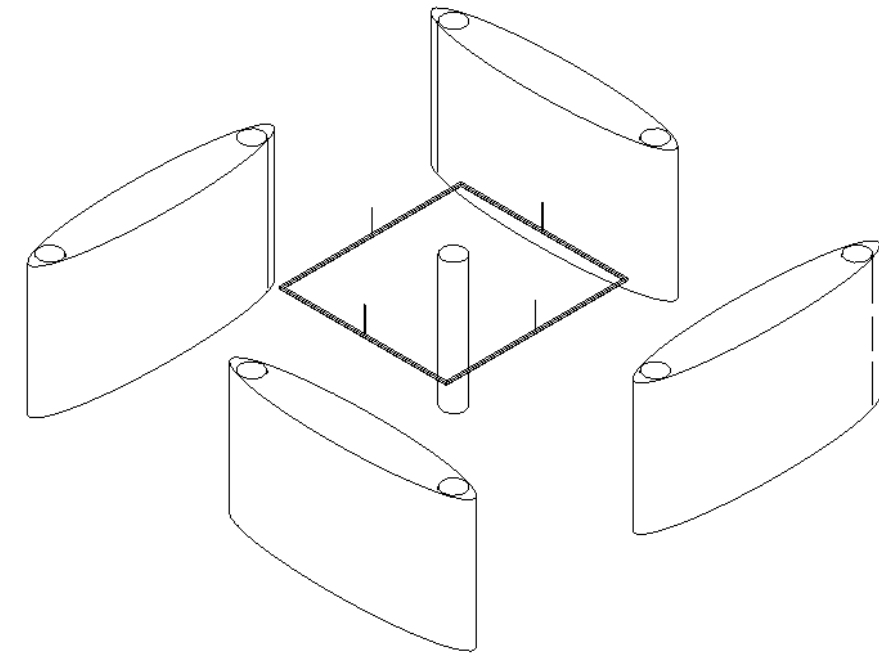
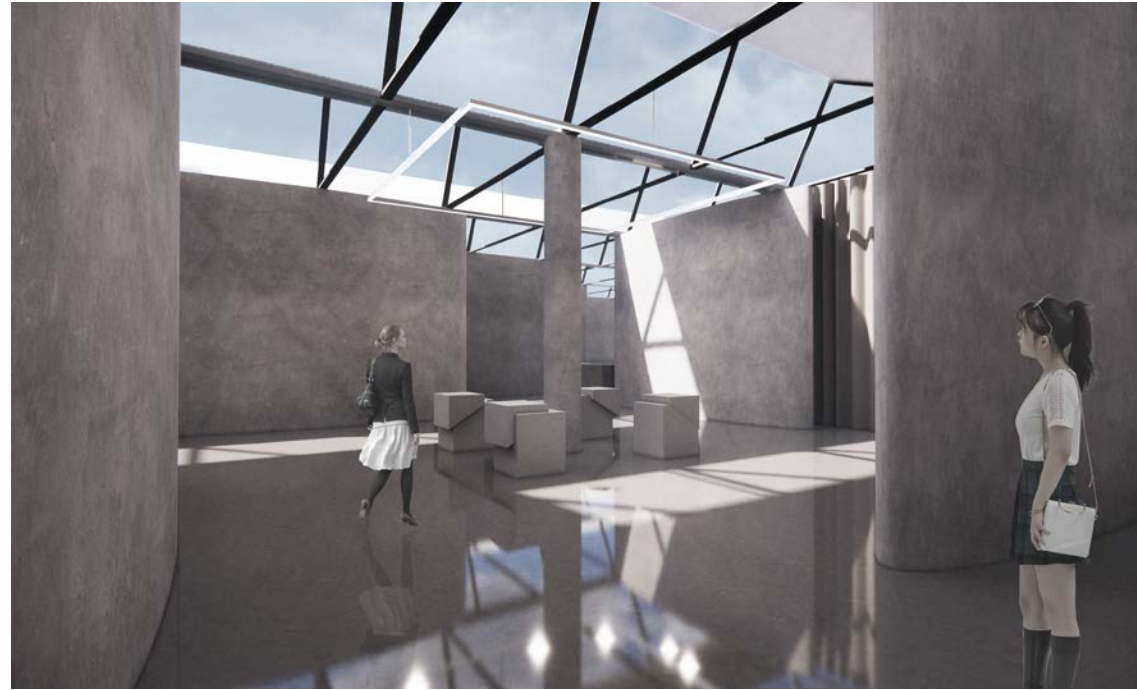
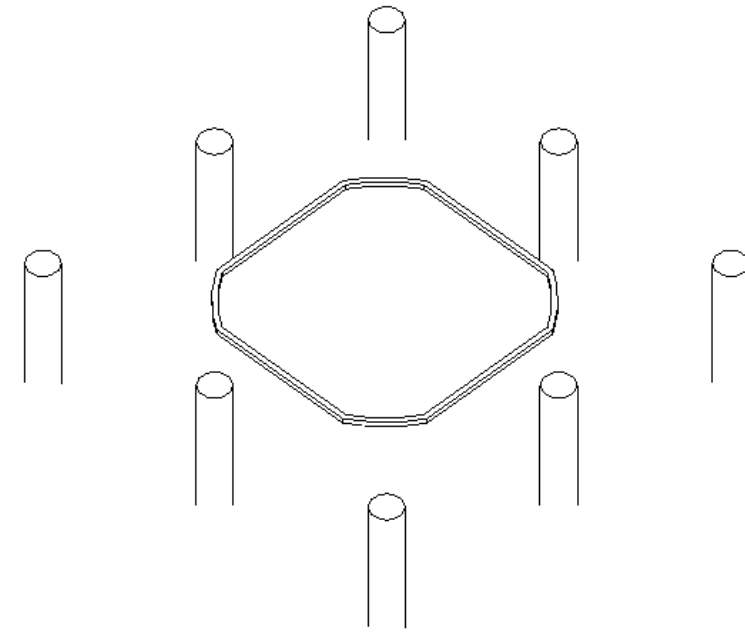

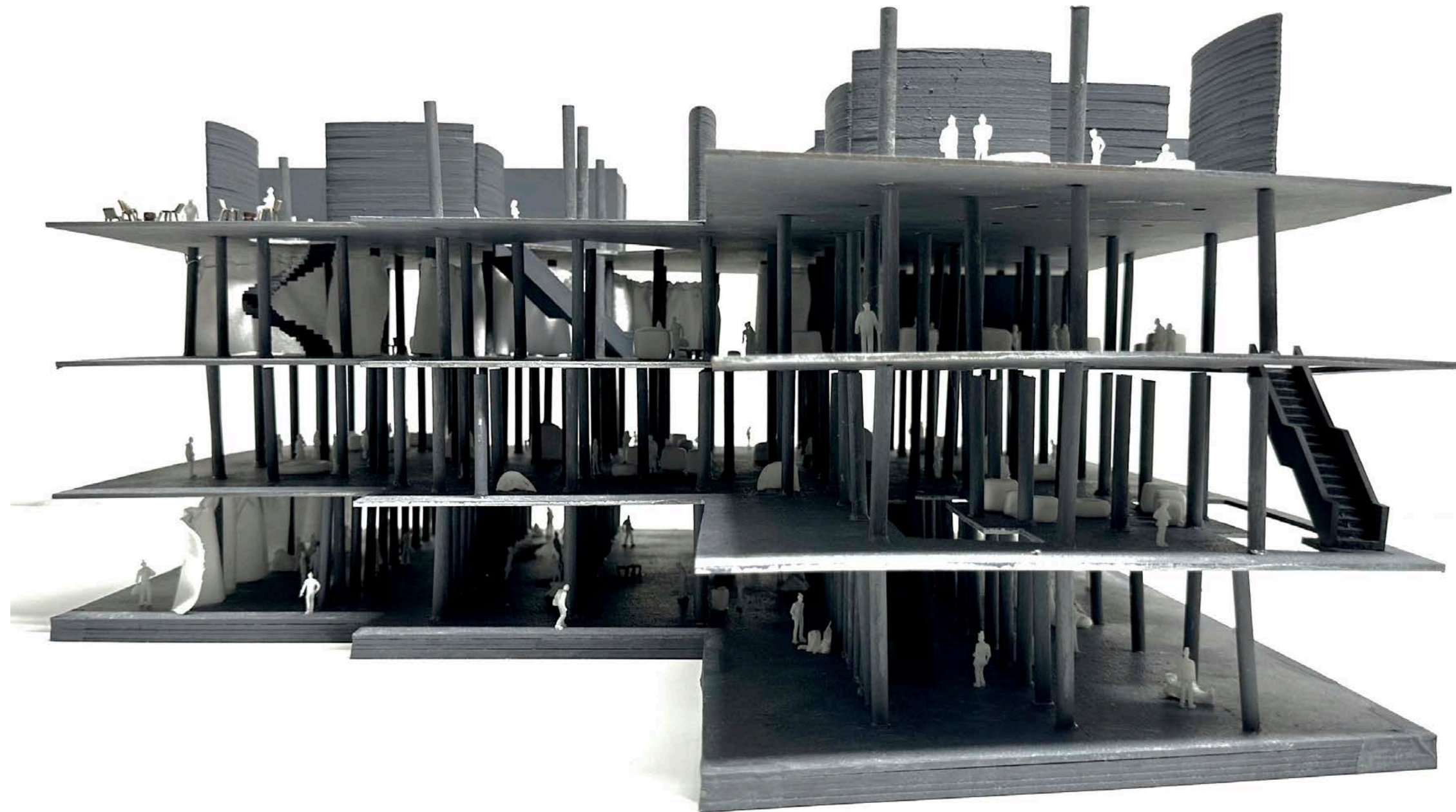

Final Model

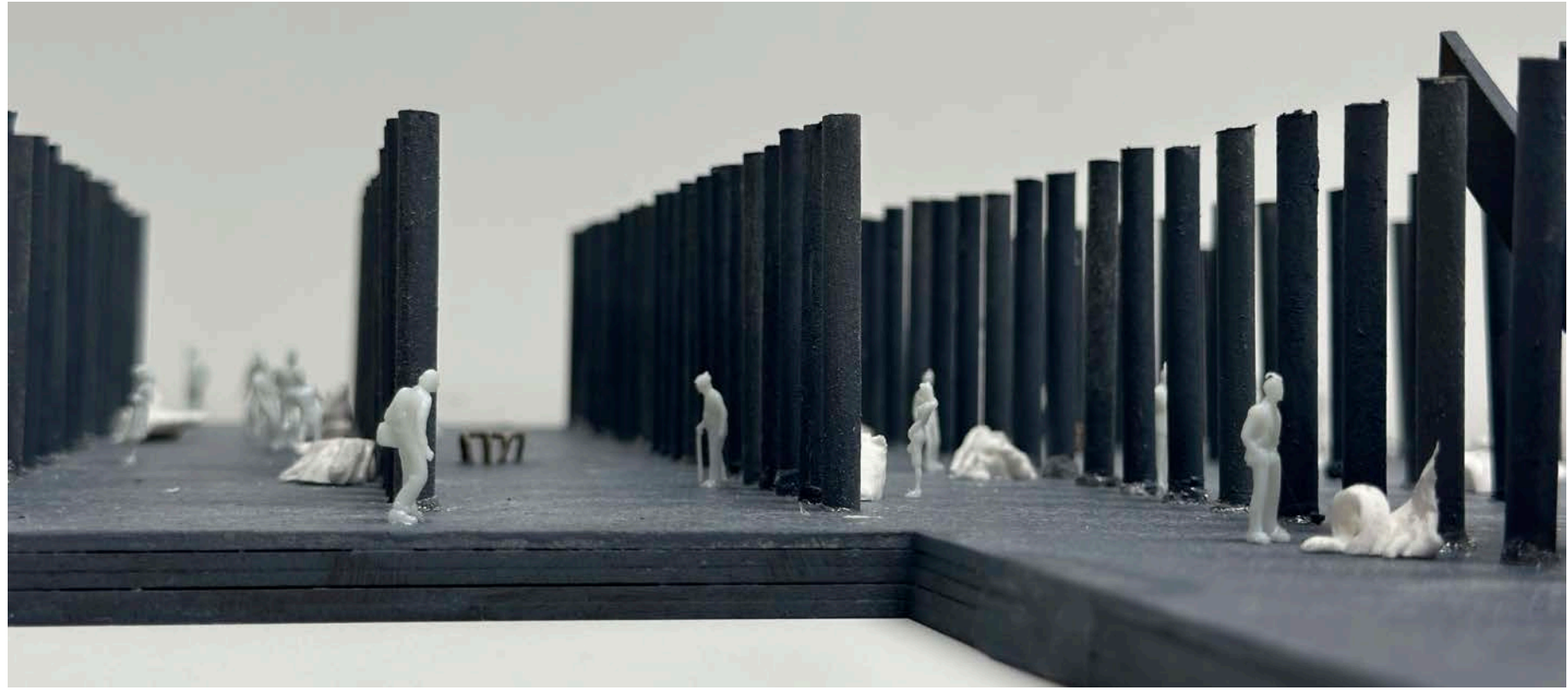

GF

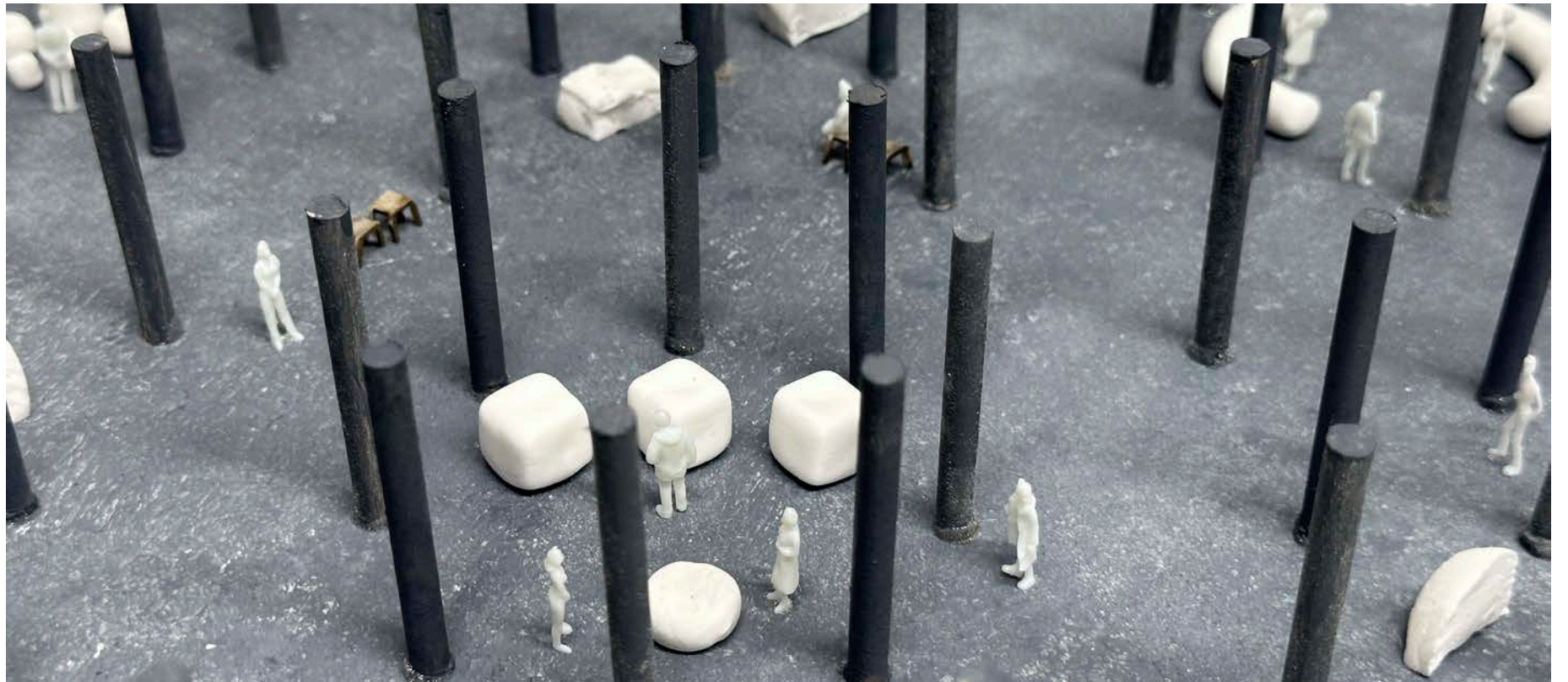

1F



2F

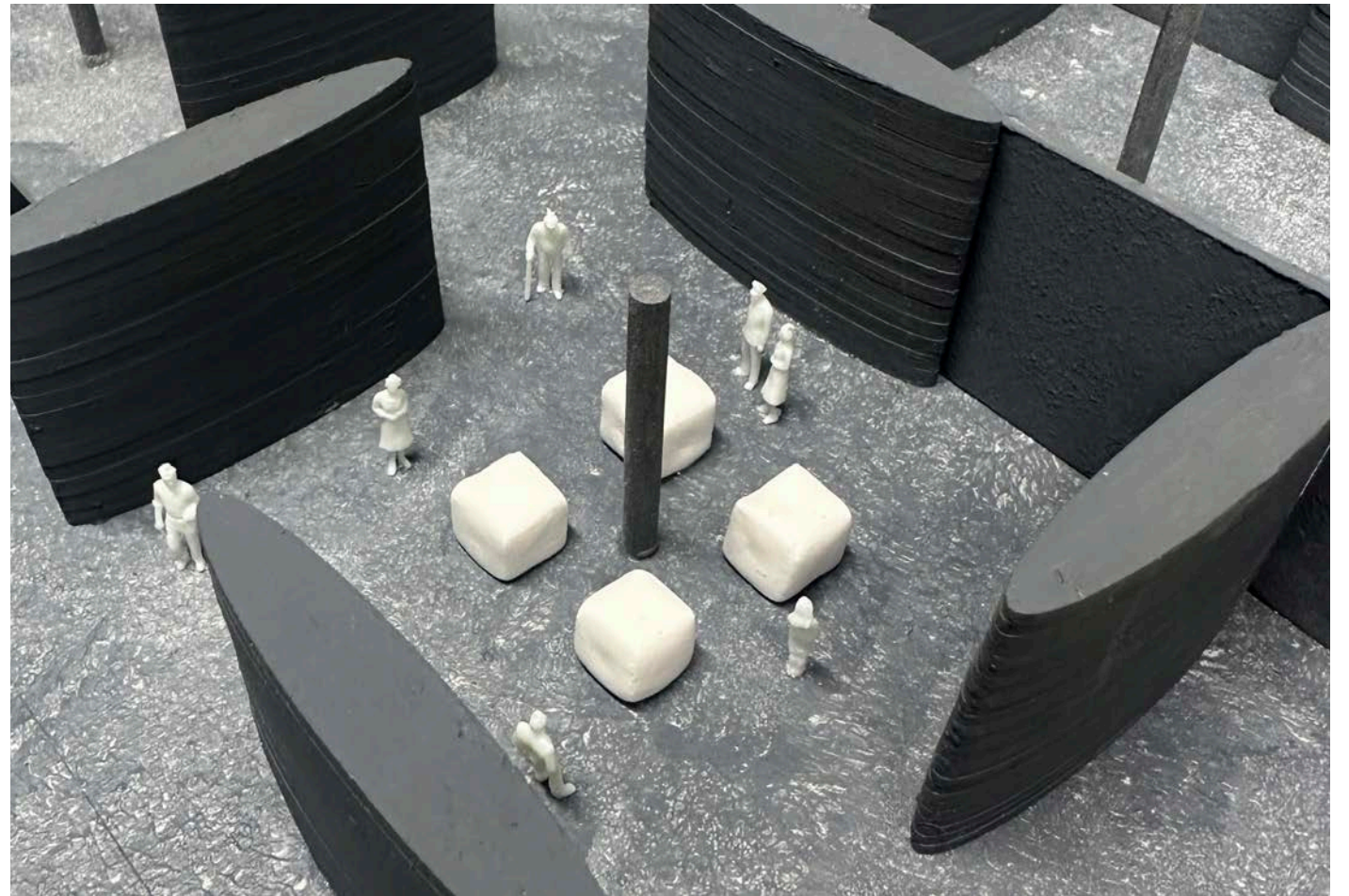

3F

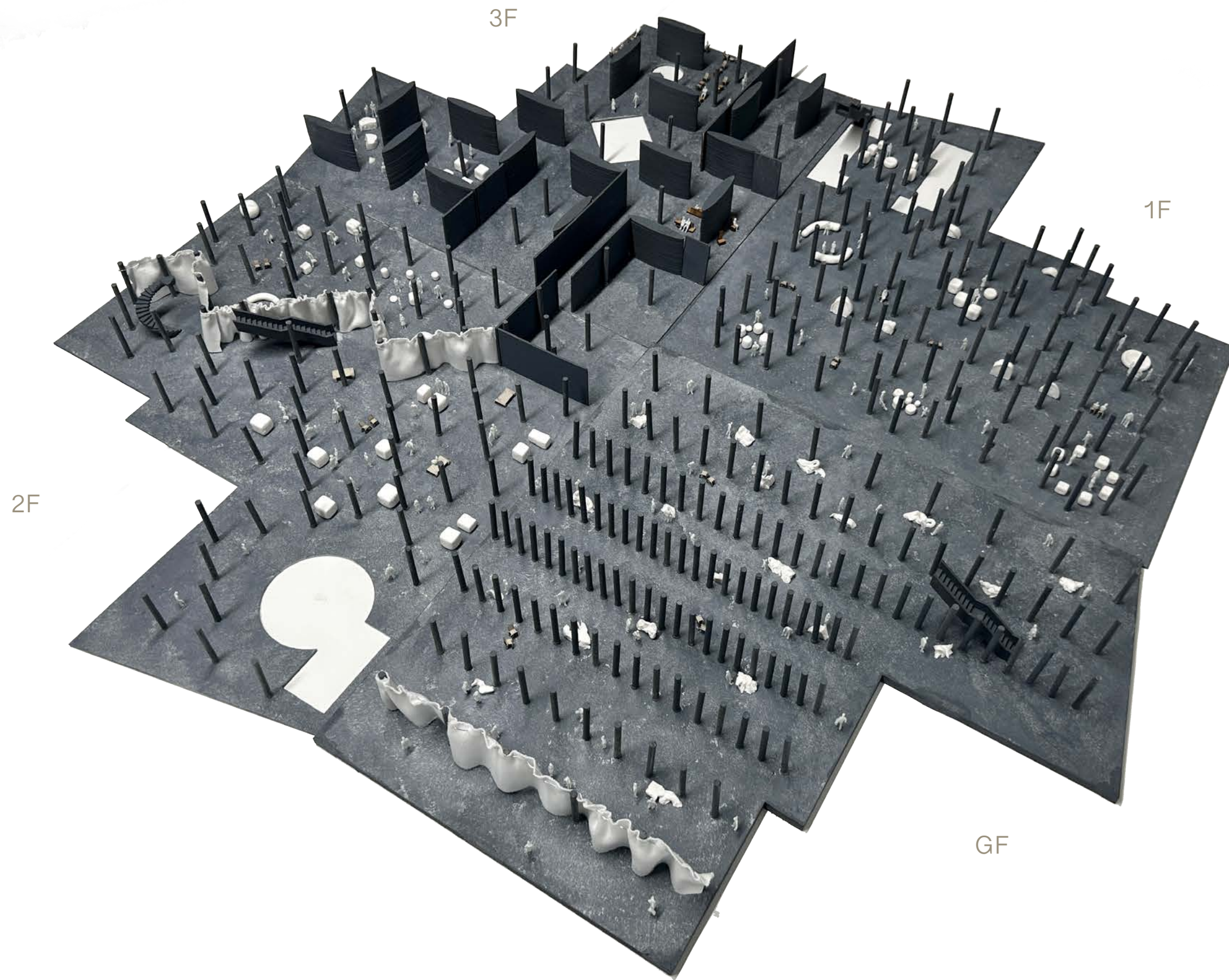

3F

1F

2F

GF

Model in Plan View

The image shows a close-up, grayscale view of a perforated metal surface. The surface is covered with a regular grid of small, circular holes. In the center of the image, there is a horizontal, light-colored rectangular box containing the word "END" in a serif font. The lighting creates a slight gradient from left to right, with the right side appearing slightly brighter and more reflective. The overall texture is metallic and industrial.

END