

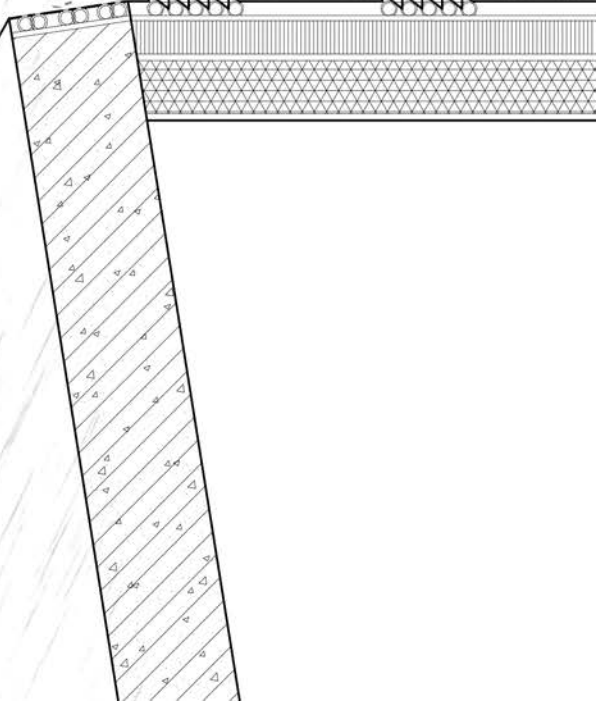

Listen, something... Singing?

MIGRATORY BIRD
XIAOYU CHEN



sound (n.)

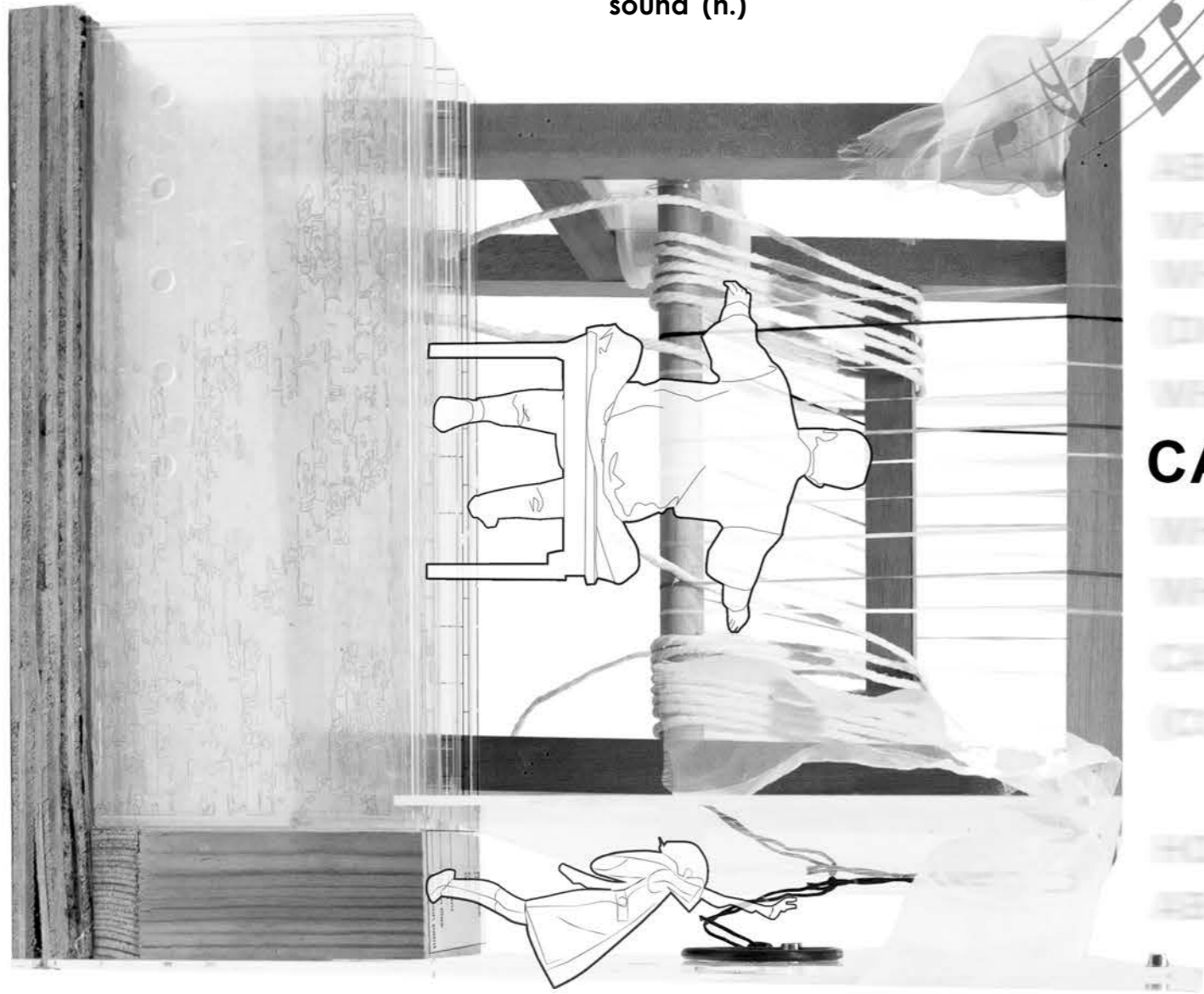

ABOUT INTERIOR

WHAT DO YOU BRING INTO THE INTERIOR FOR IT TO SING, OR
WHETHER THE INTERIOR ALREADY HAS THE SOUND?

(DIFFERENT INTERIOR HAVE DIFFERENT SOUNDS)

WHAT KIND OF INTERIOR?

CAN THE DESIGN MAKE AN INTERIOR SING?

WHO IS THIS SOUNDING CROWD?

WHAT SOUND IT WILL BE?

CAN TRANSLATE A PIECE OF SOUND?

(COME TO THE SITE RECORD SOUNDS, CODIFY IT)

HOW CAN YOU MAKE NOTES WITH ARCHITECTURAL ELEMENTS?

ABOUT SOUND



THE MIGRATORY BIRDS

AMPLIFY

THE LEFT SOUND

JOURNEY

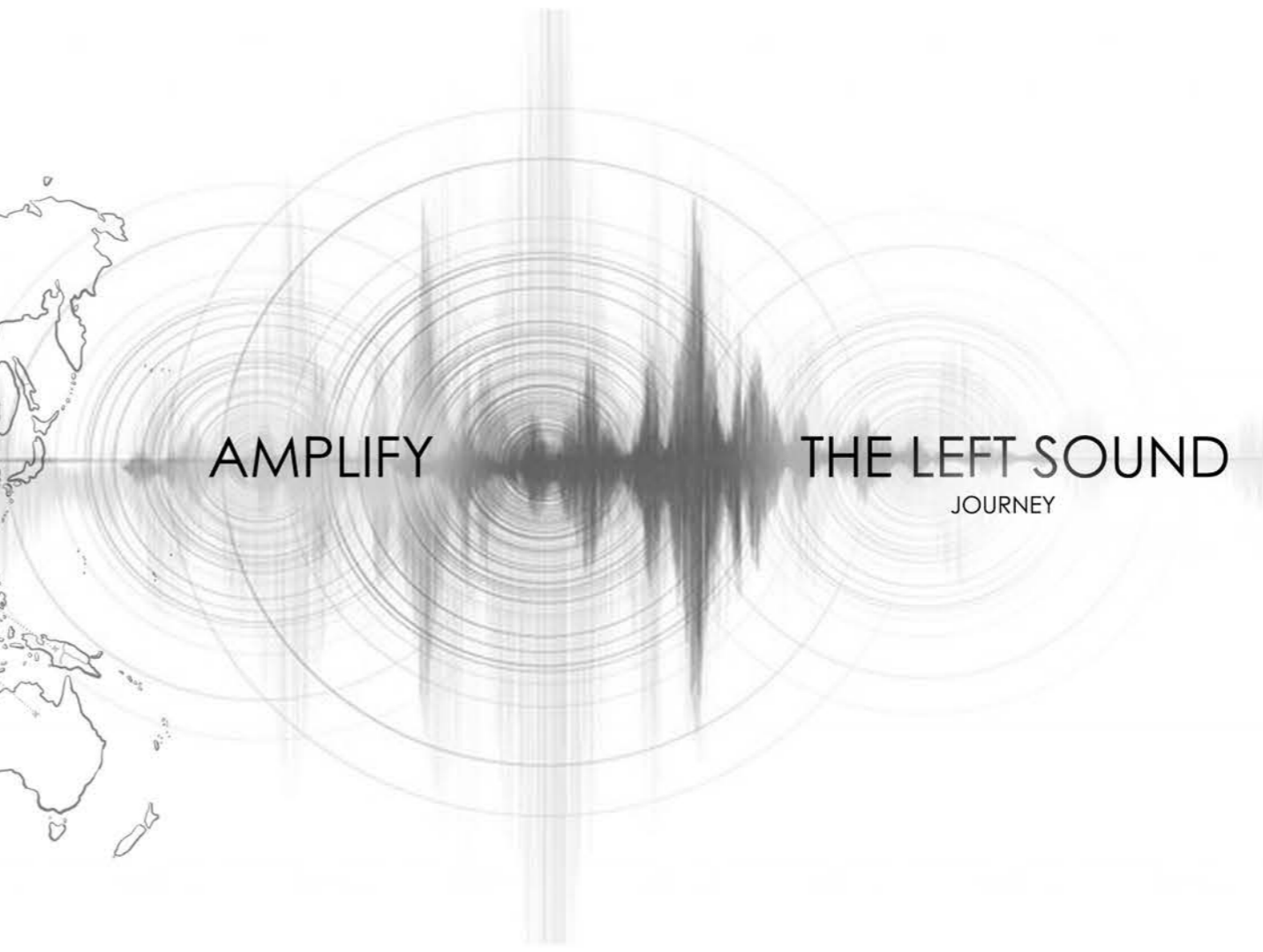

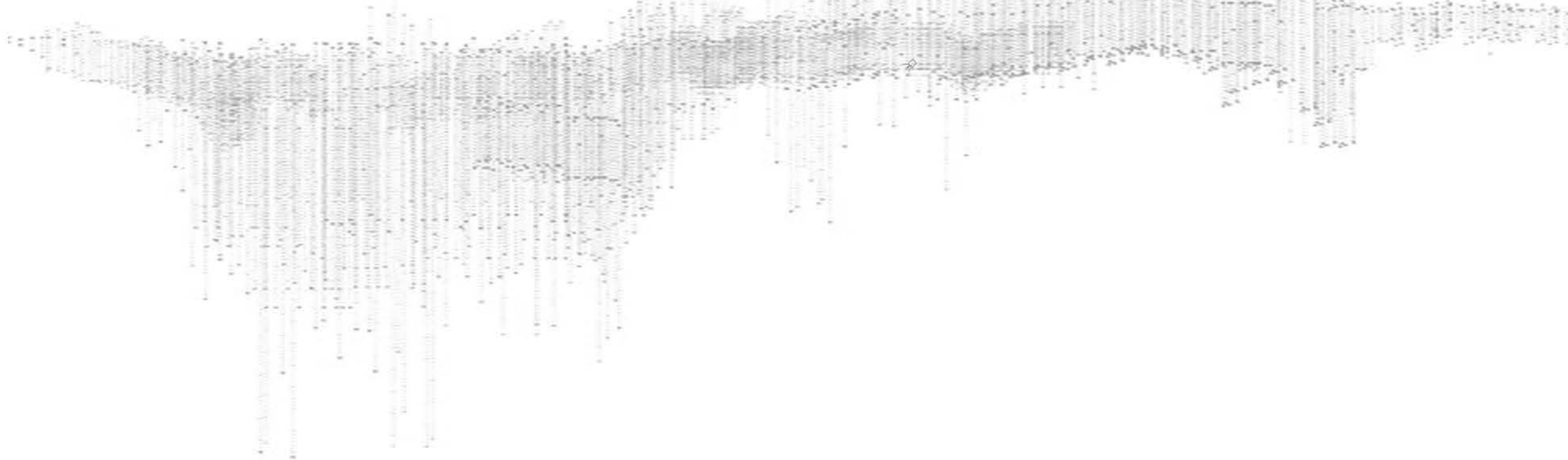
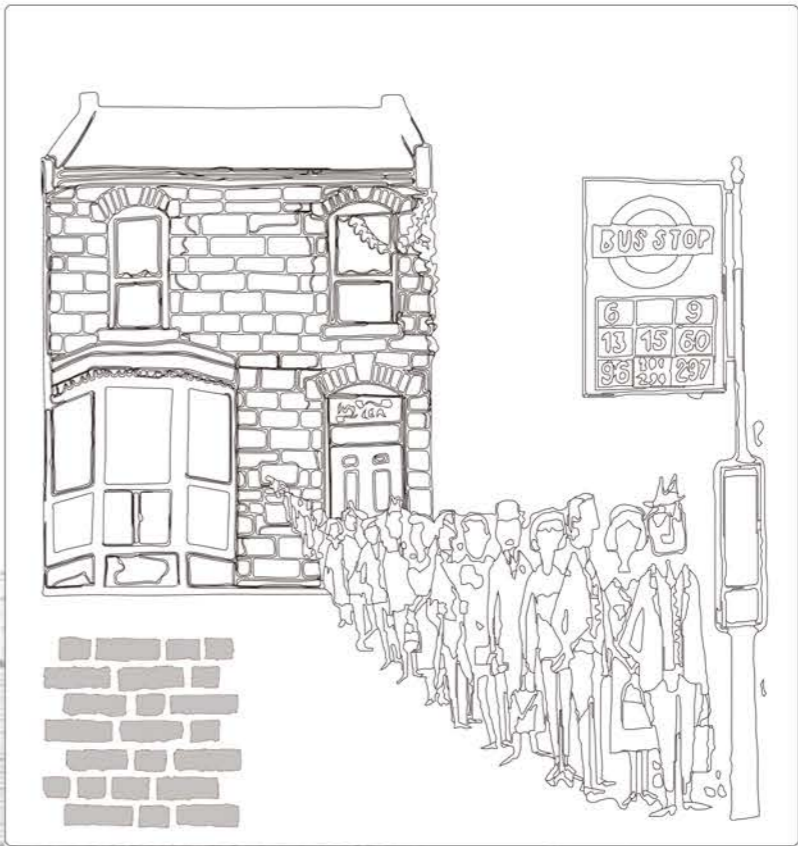
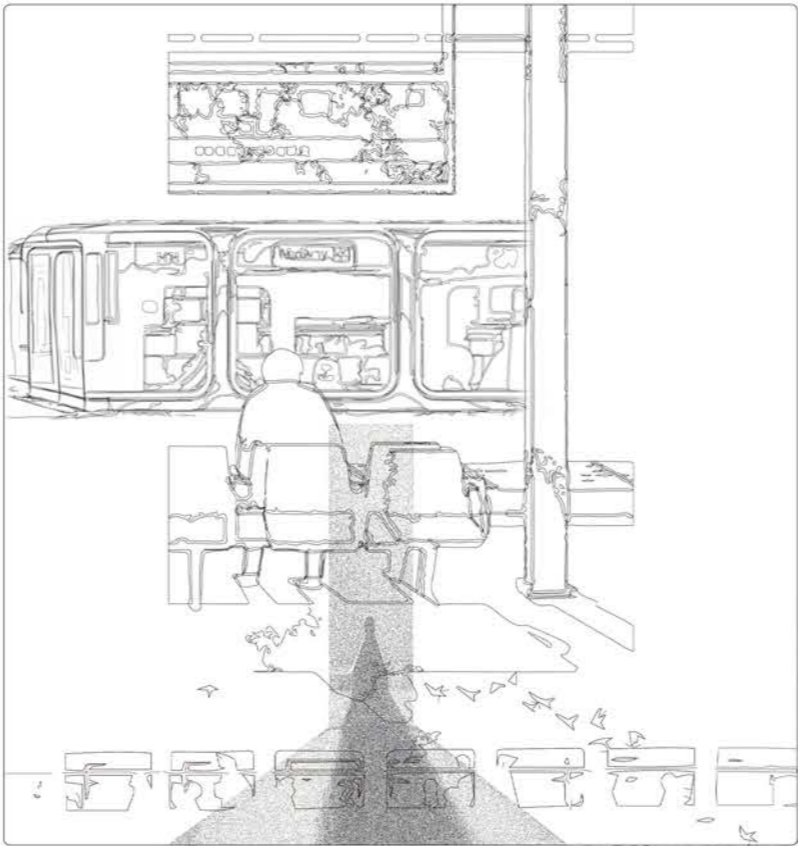
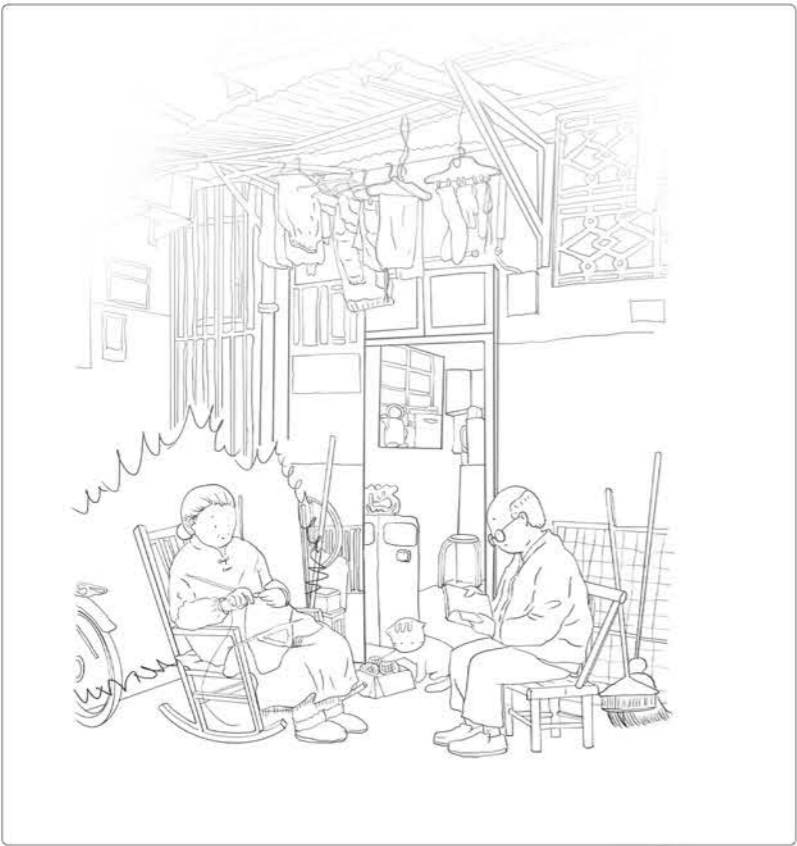

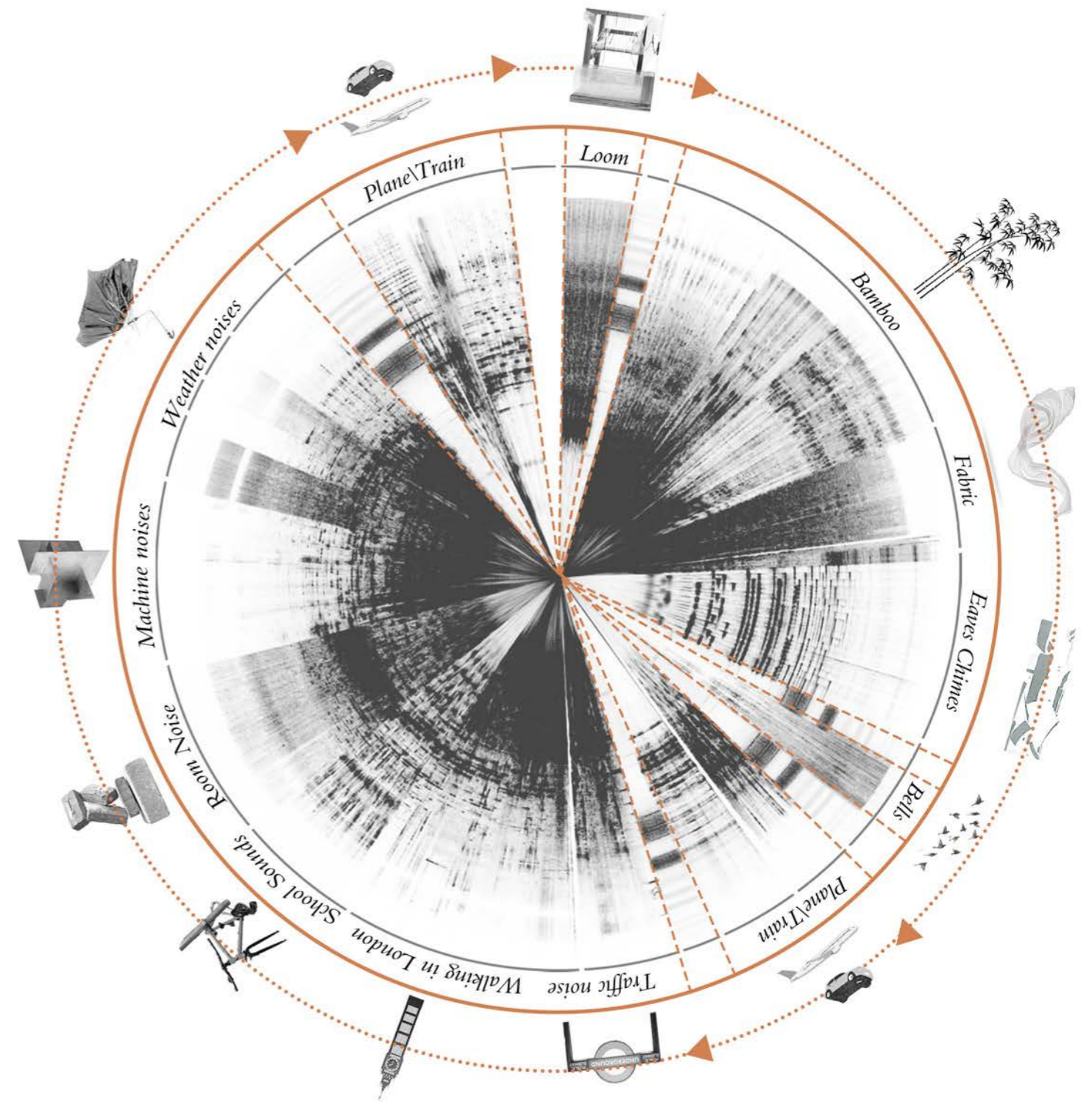

This is a story from China to The UK. I recorded many sounds I encountered during this year and translated them into sound wheels and sound waves, trying to find out how the abstract concept of sound can relate to space.

The **FIRST** connection is **MATERIAL**.

We can see everything from the sound of looms back home, to the sound of the wind blowing through the bamboo forest, to the sound of machines making silk, to the hum of transport, the hum of bricks in London and the sound of umbrellas being held up in the rain in London.

All of these materials are witnesses to this journey, **carriers of sound**

STORIES OF MIGRATORY YOUNG PEOPLE

IMMERSIVE SOUND THEATRE

ACT2

ON THE WAY

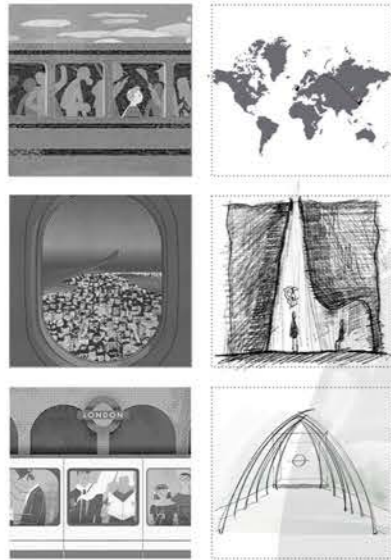

ACT3

STAY IN LONDON

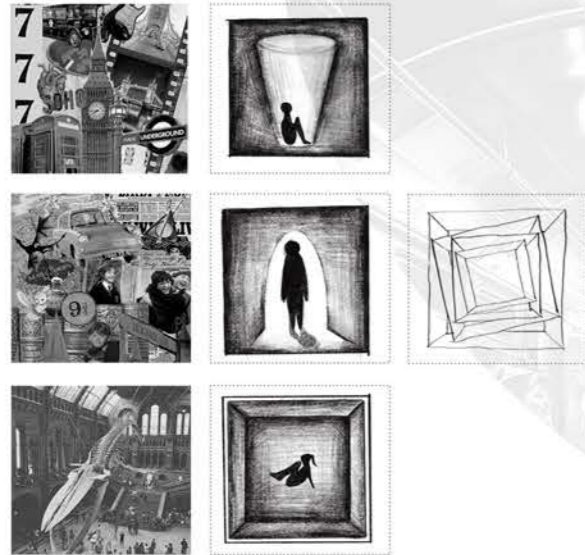

ACT1

HOME

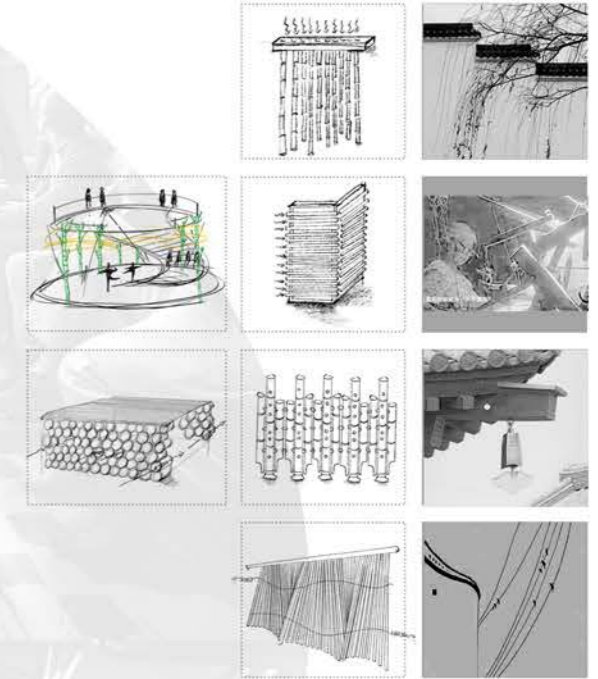

ACT4

COME BACK

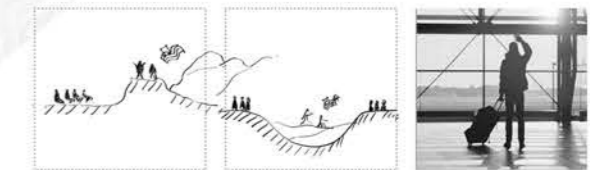

HOW

How to transfer recorded sound and script into architectural interiors



So I began to think, how does this translate this circular journey into the interior and realise the vision of making the space sing?

Now that I had my recorded voices, the plays, the materials and the site, **the first step was - to transform the architecture.**

AI

Rectangles
Sound wave
Triangular

Firstly, I used AI to deconstruct the **sound waves** and found that they are an **infinite offset of rectangles and triangles**. Based on this, I determined that the overall **design language** was a combination of **rectangles and triangles**.

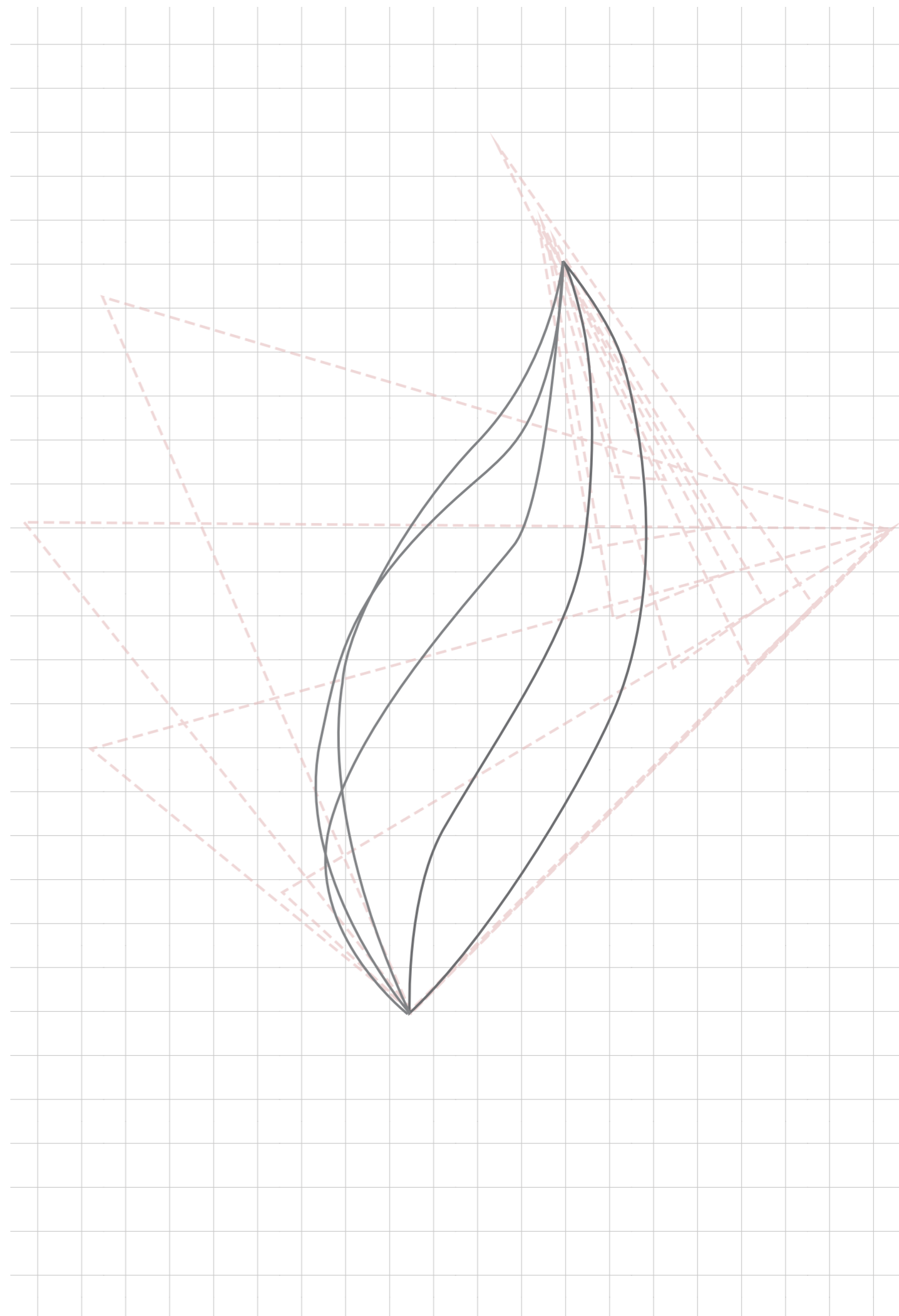

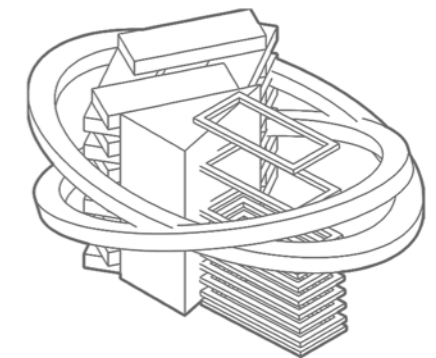
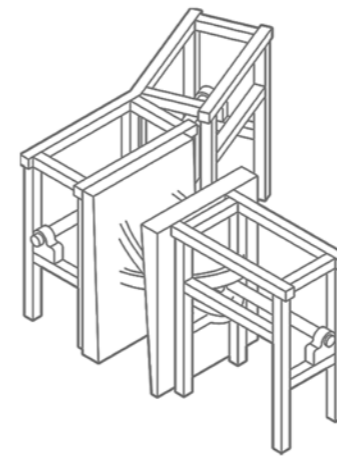
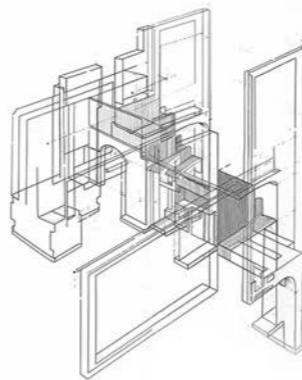
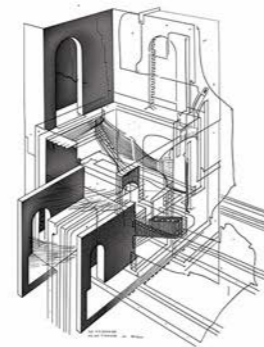
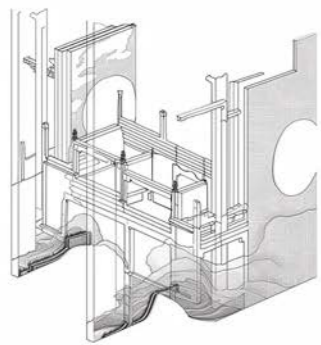
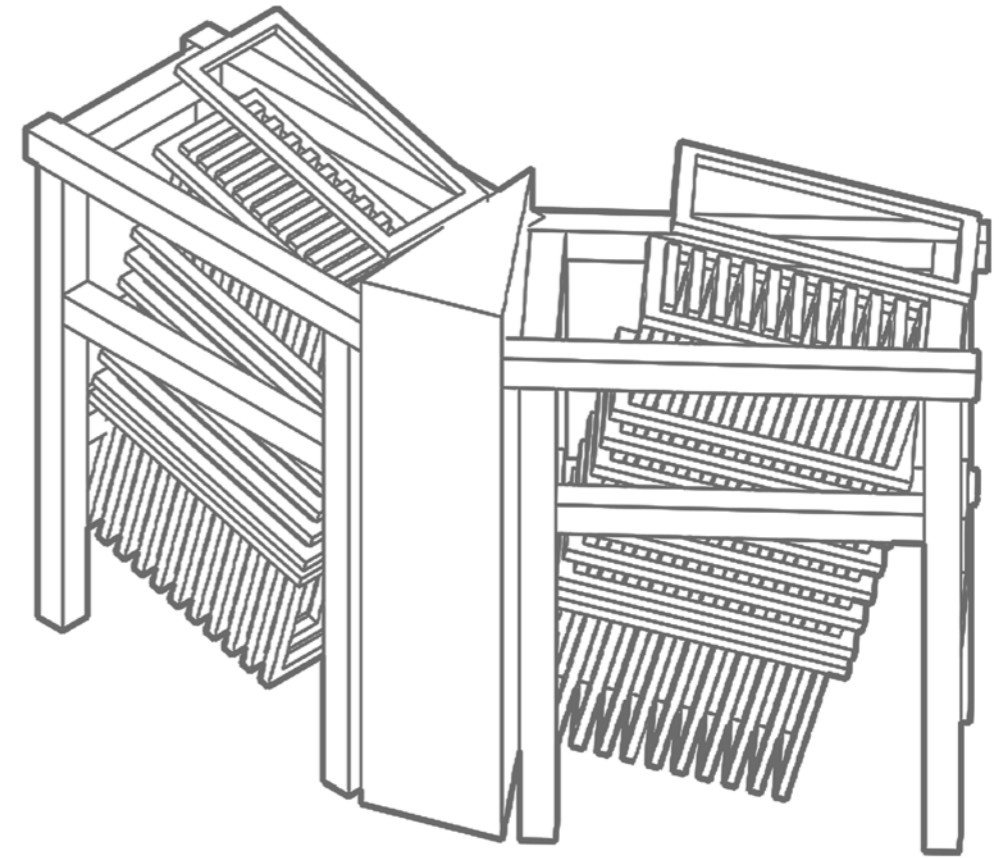
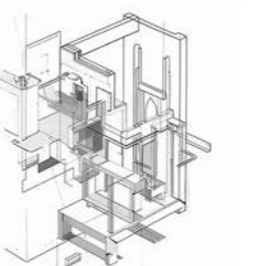
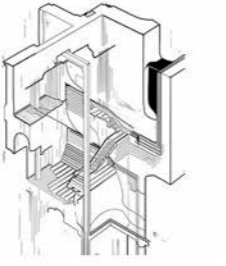
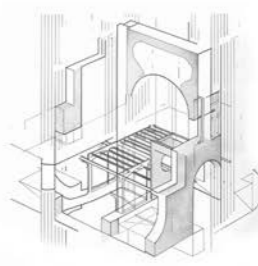
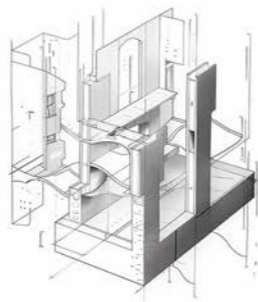
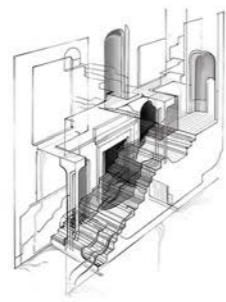
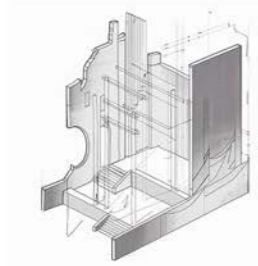

PROMPT: Loom Structures, Rotating Box, Circulation, Connection, Regular Geometric, Cyclic Journey

ACT 3

Daily Life in London

Transport in London

Pieces of London Memory

Studying in London

ACT 3 consists of four rows. Each row contains a soundscape visualization on the left, a right-pointing arrow, and an architectural diagram on the right. The diagrams show a person silhouette and concentric circles representing sound waves. The first diagram shows a person standing near a wall with sound waves emanating from it. The second shows a person in a room with sound waves. The third shows a person in a room with a large window and sound waves. The fourth shows a person in a room with a brick wall and sound waves.

ACT 4

Transport

Transport

ACT 4 consists of two rows. Each row contains a soundscape visualization on the left, a right-pointing arrow, and an architectural diagram on the right. The diagrams show a person silhouette and concentric circles representing sound waves. The first diagram shows a person standing in a room with sound waves. The second shows a person in a room with sound waves.

ACT 1

Loom

Bamboo forest

Qingping's home

School

woodland

ACT 1 consists of five rows. Each row contains a soundscape visualization on the left, a right-pointing arrow, and an architectural diagram on the right. The diagrams show a person silhouette and concentric circles representing sound waves. The first diagram shows a person standing in a room with sound waves. The second shows a person in a room with sound waves. The third shows a person in a room with sound waves. The fourth shows a person in a room with sound waves. The fifth shows a person in a room with sound waves.

ACT 2

Transport

ACT 2 consists of one row. It contains a soundscape visualization on the left, a right-pointing arrow, and an architectural diagram on the right. The diagram shows a person silhouette and concentric circles representing sound waves.

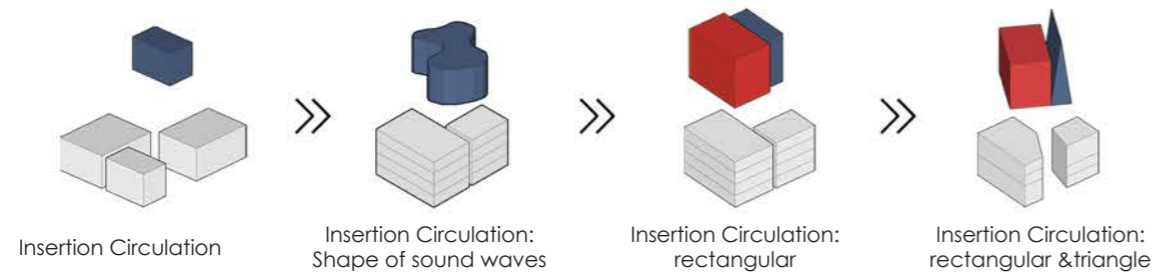
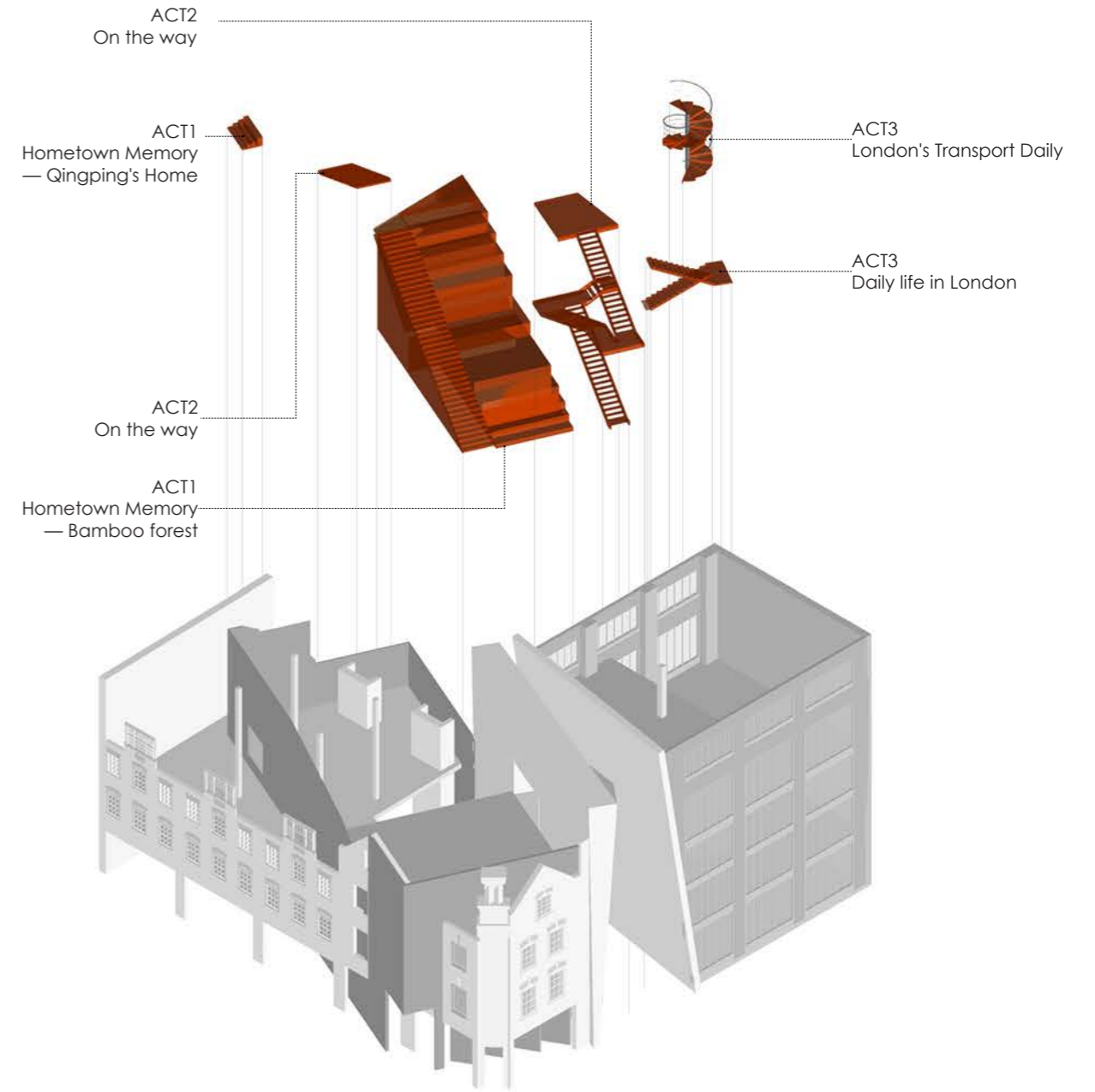
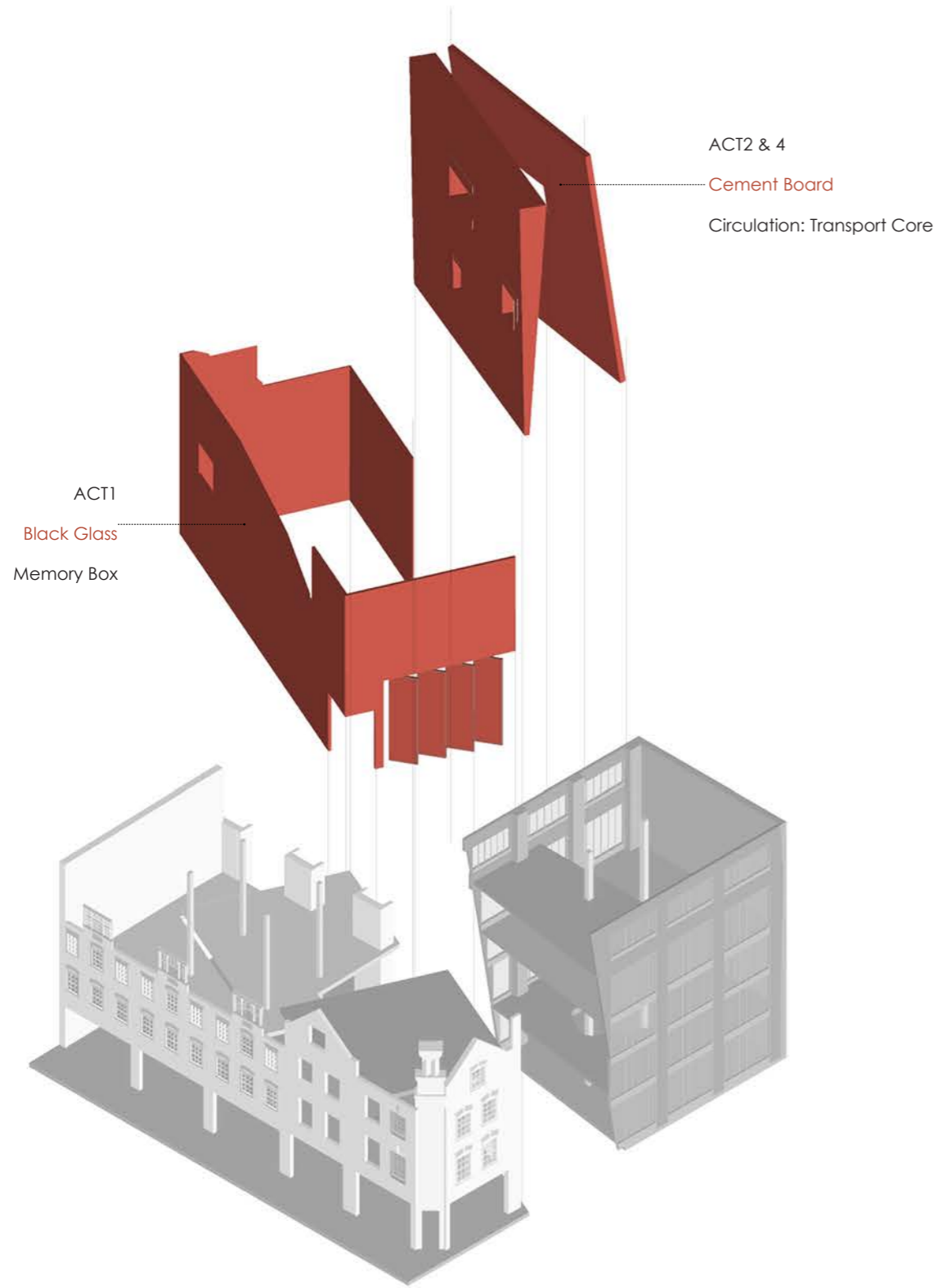

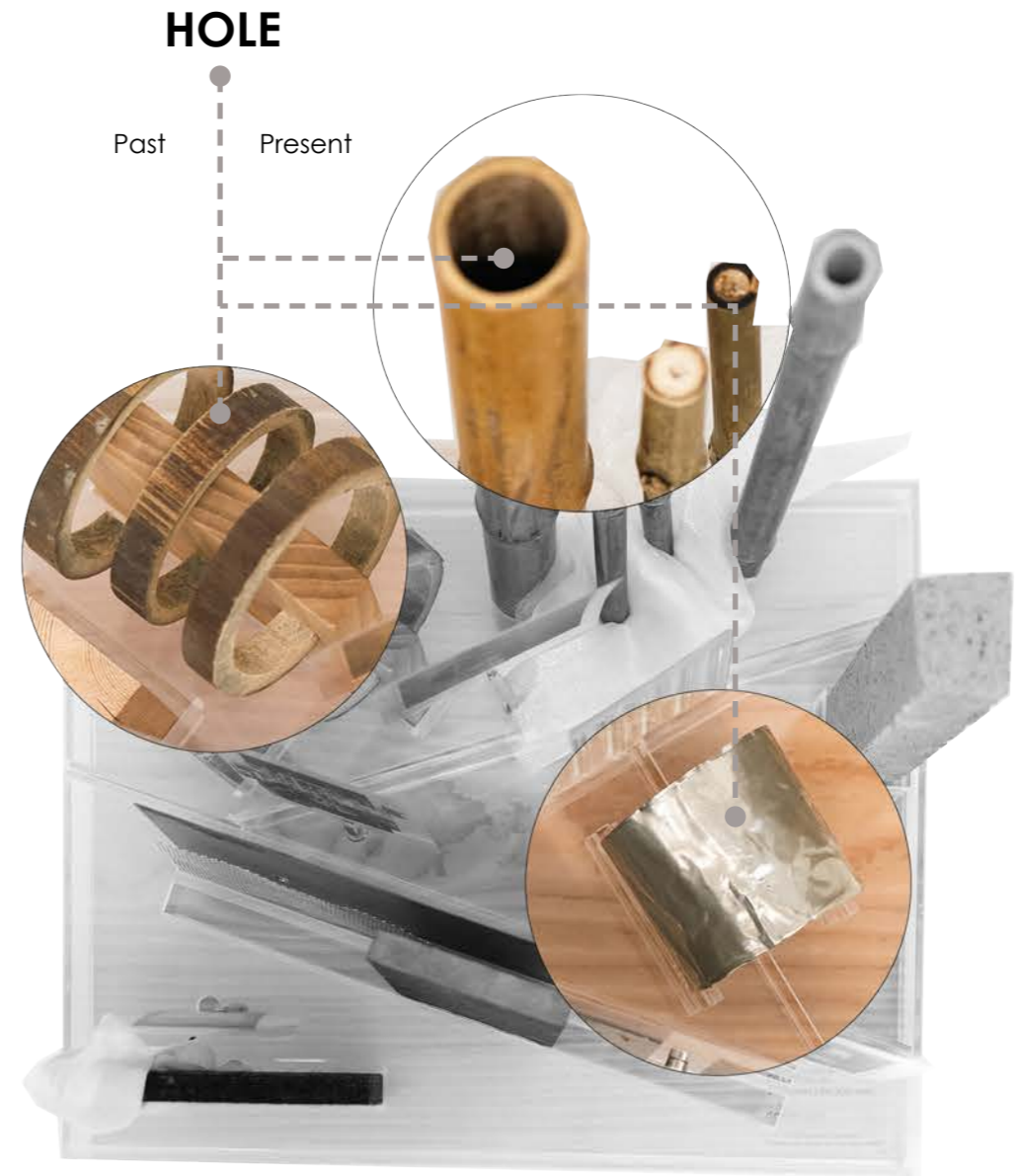
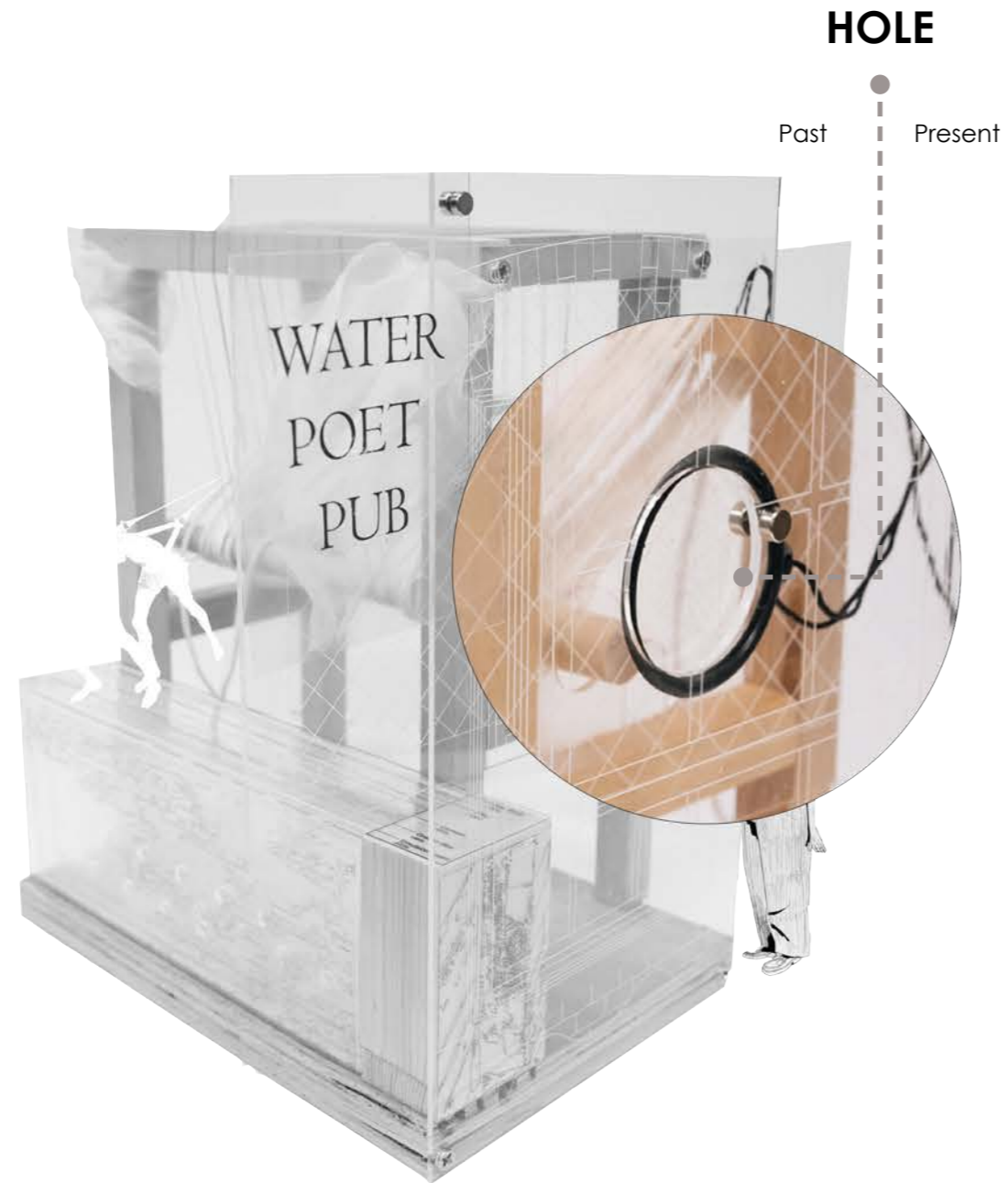





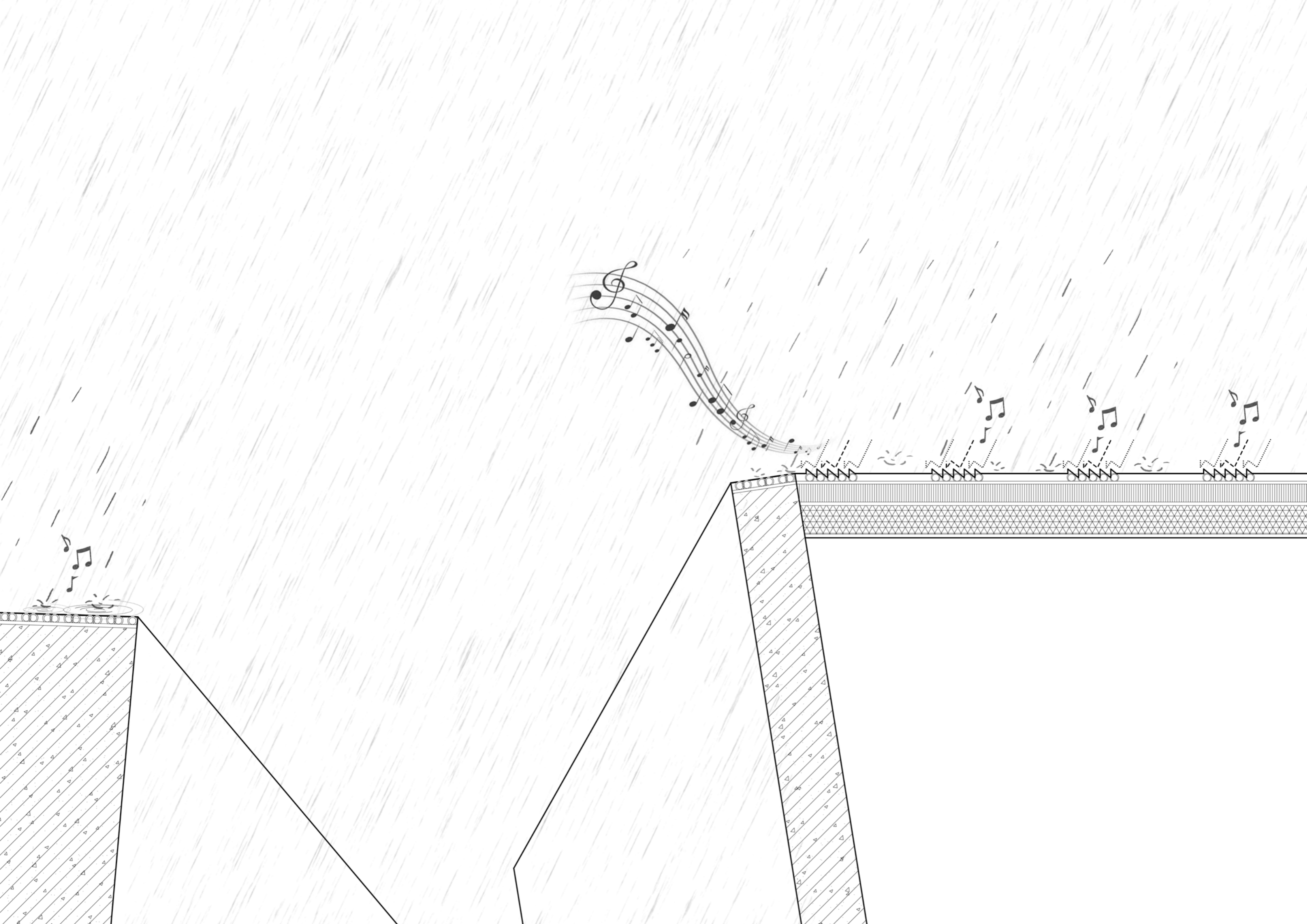

ACT 1

Home

Childhood Memories

MAIN MATERIAL

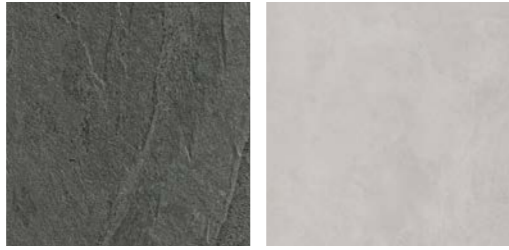

It is a theatre of sounds translated to carry the memories and journeys of migratory birds. It is a journey, a journey that originates in sound and makes the building sing.

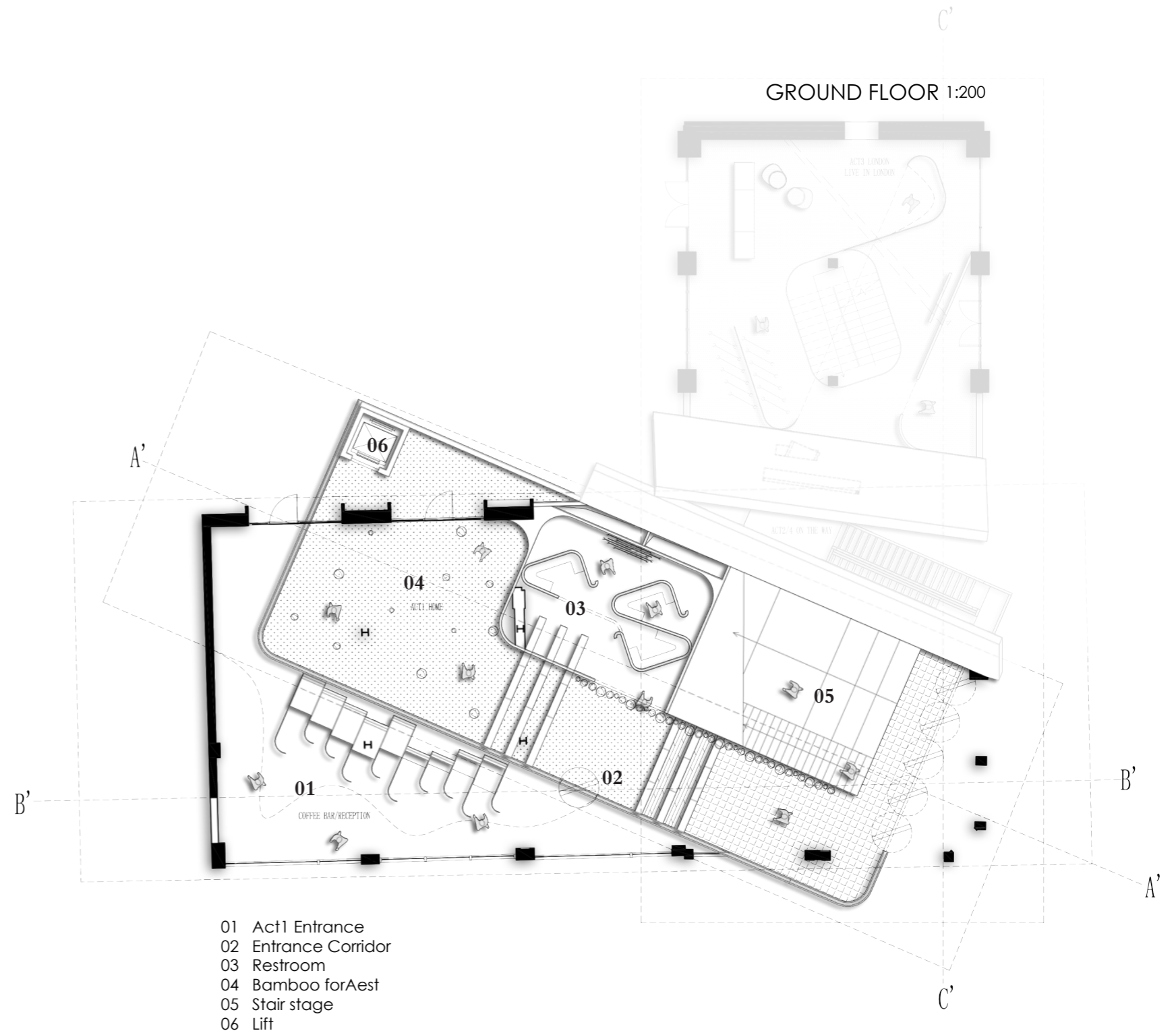

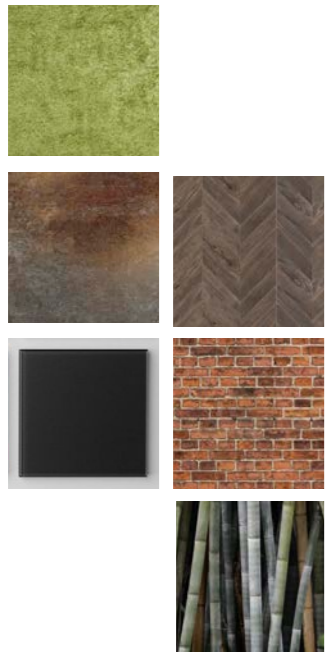

SECOND FLOOR 1:200

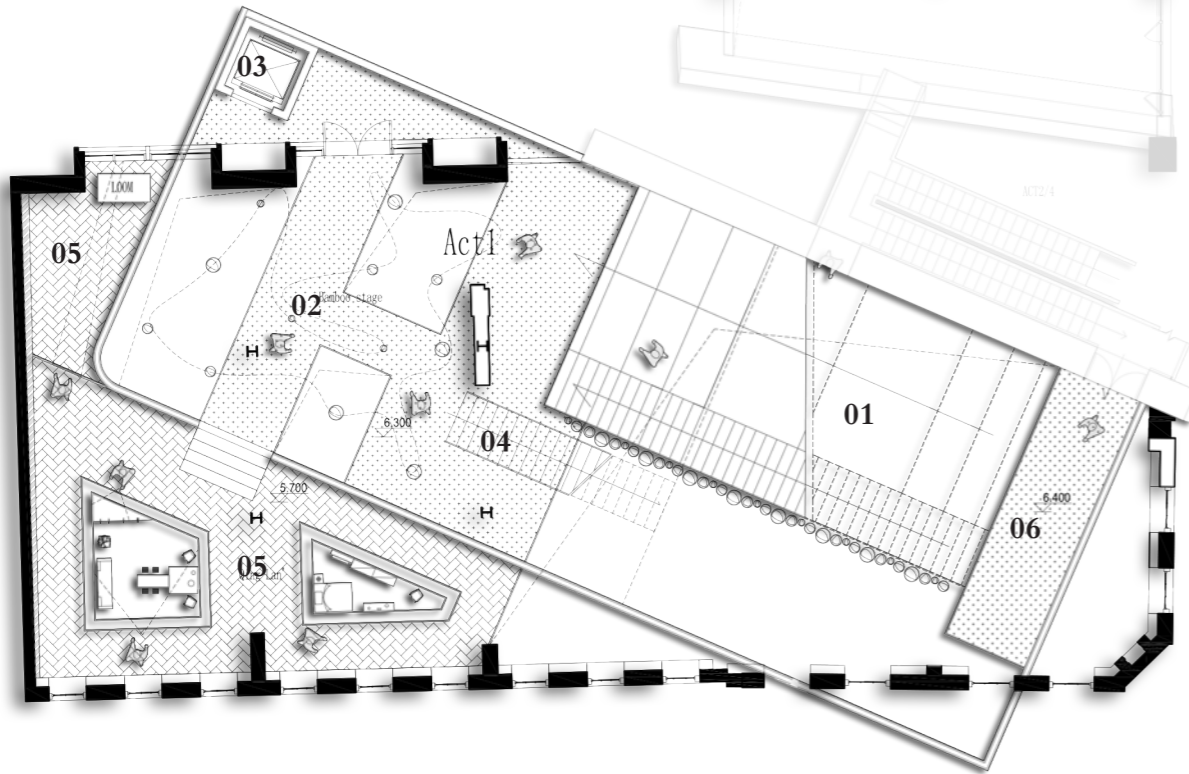
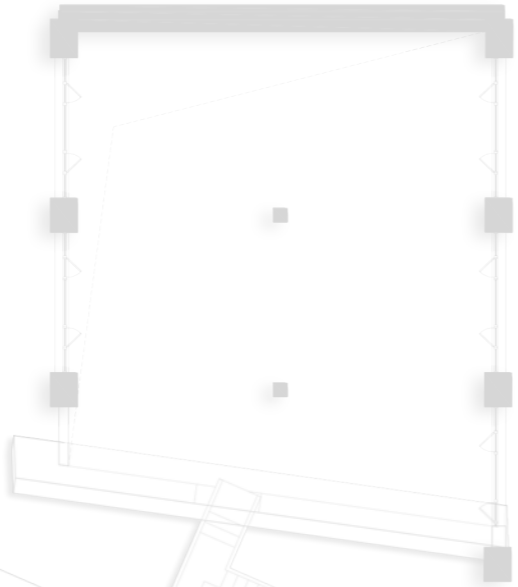

- 01 Stair Stage
- 02 Bamboo forest
- 03 Lift
- 04 Stairs To The Third Floor
- 05 Qinglan's Home
- 06 Viewing stage

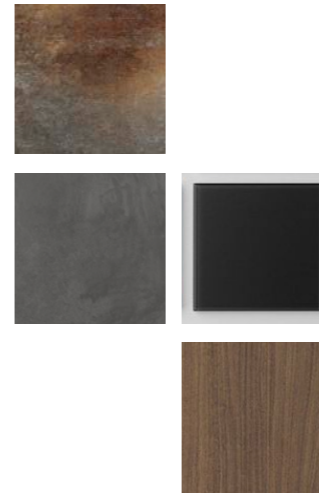

THIRD FLOOR 1:200

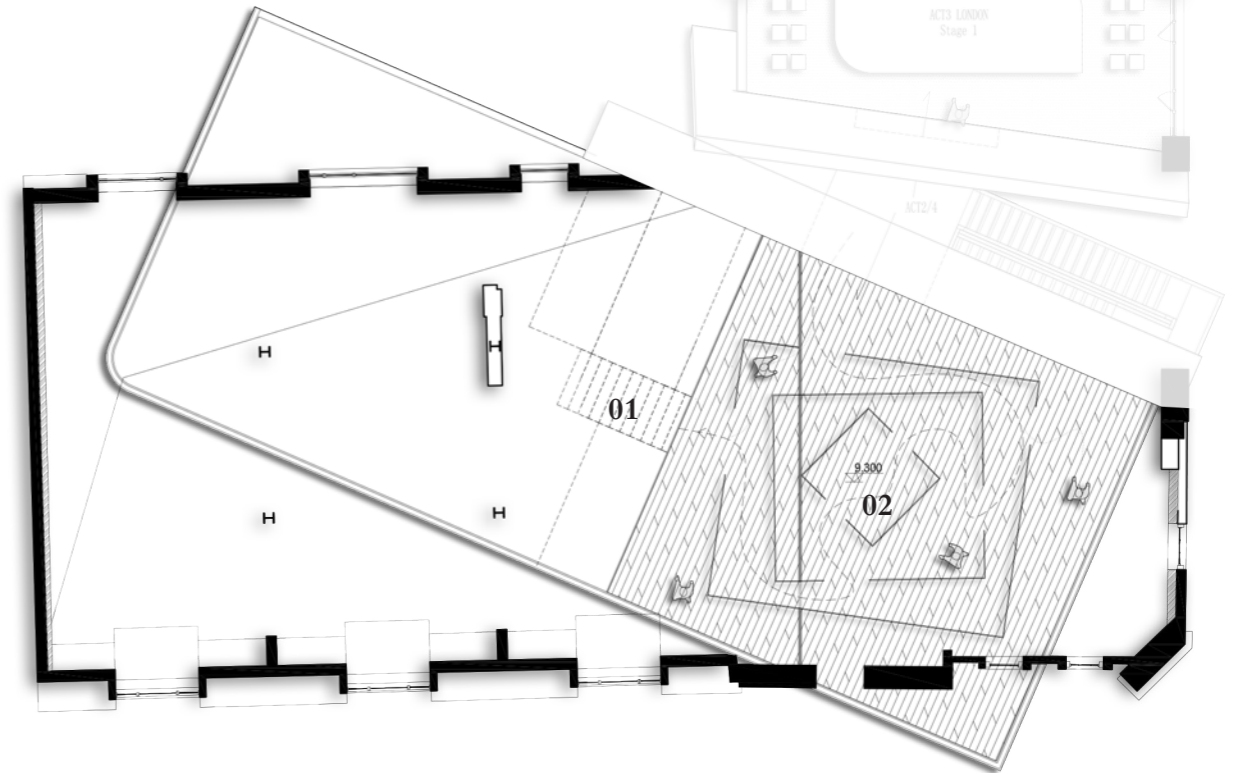
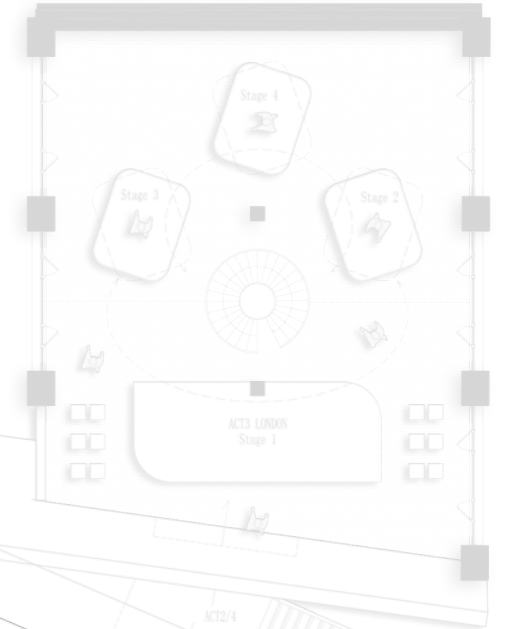

- 01 Stair
- 02 City maze





Vsist: Resonance - the hum of traffic



Vsist: Observation of Qinglan's home

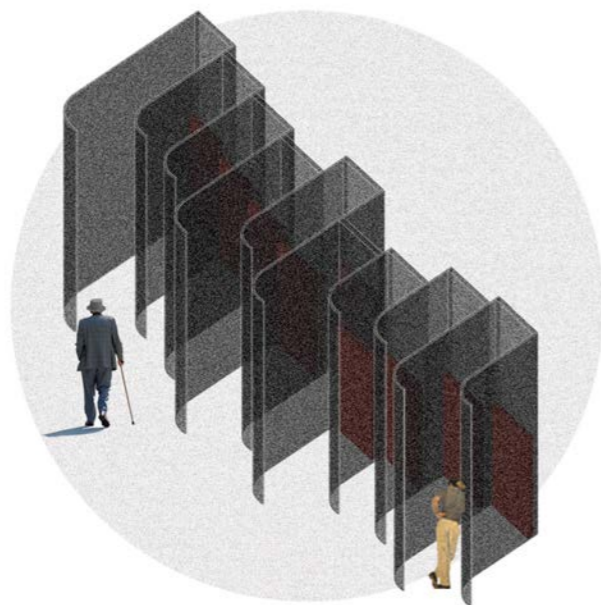

Vsist: Shape of the notes





Iteration With Material



Iteration With Material Individual

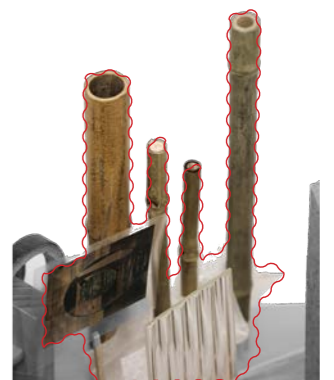



Iteration With Material



Iteration With Material Individual



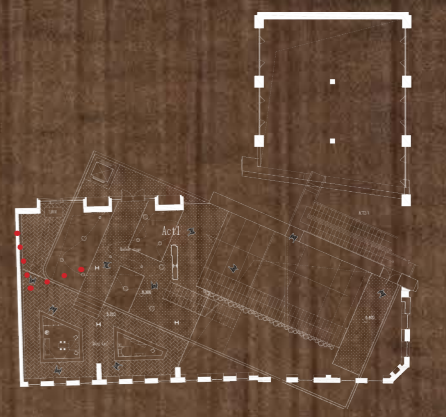

Iteration With Material



Iteration With Material Individual

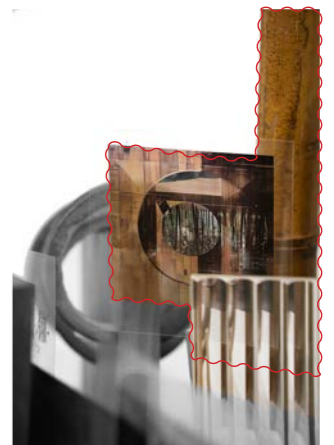

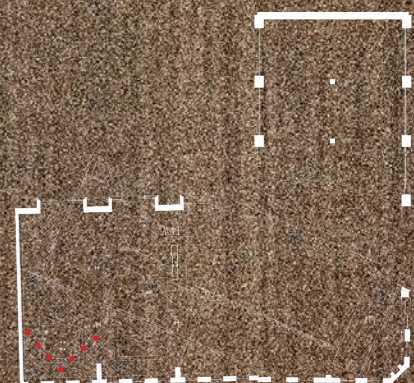

Iteration With Material



Iteration With Material Individual

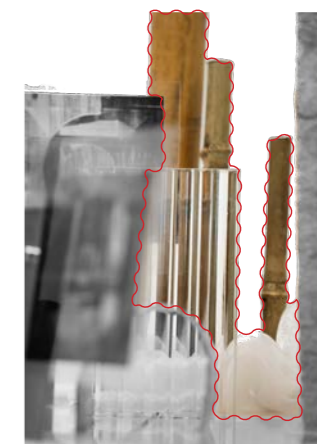

ACT 2&4

On the road

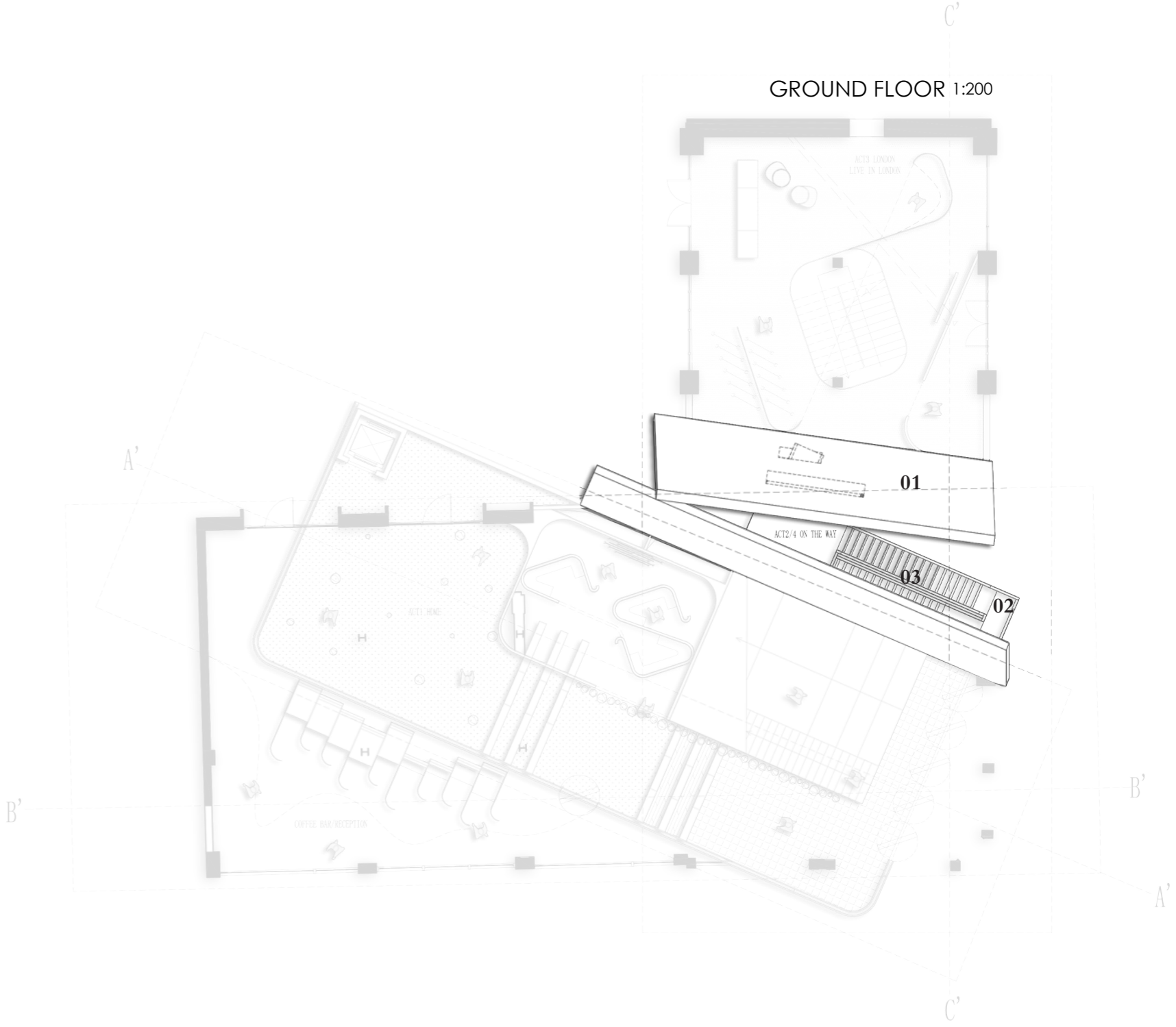

MAIN MATERIAL



It is a theatre of sounds translated to carry the memories and journeys of migratory birds. It is a journey, a journey that originates in sound and makes the building sing.

- 01 ACT3Wall
- 02 ACT1Wall
- 03 Stair



SECOND FLOOR 1:200

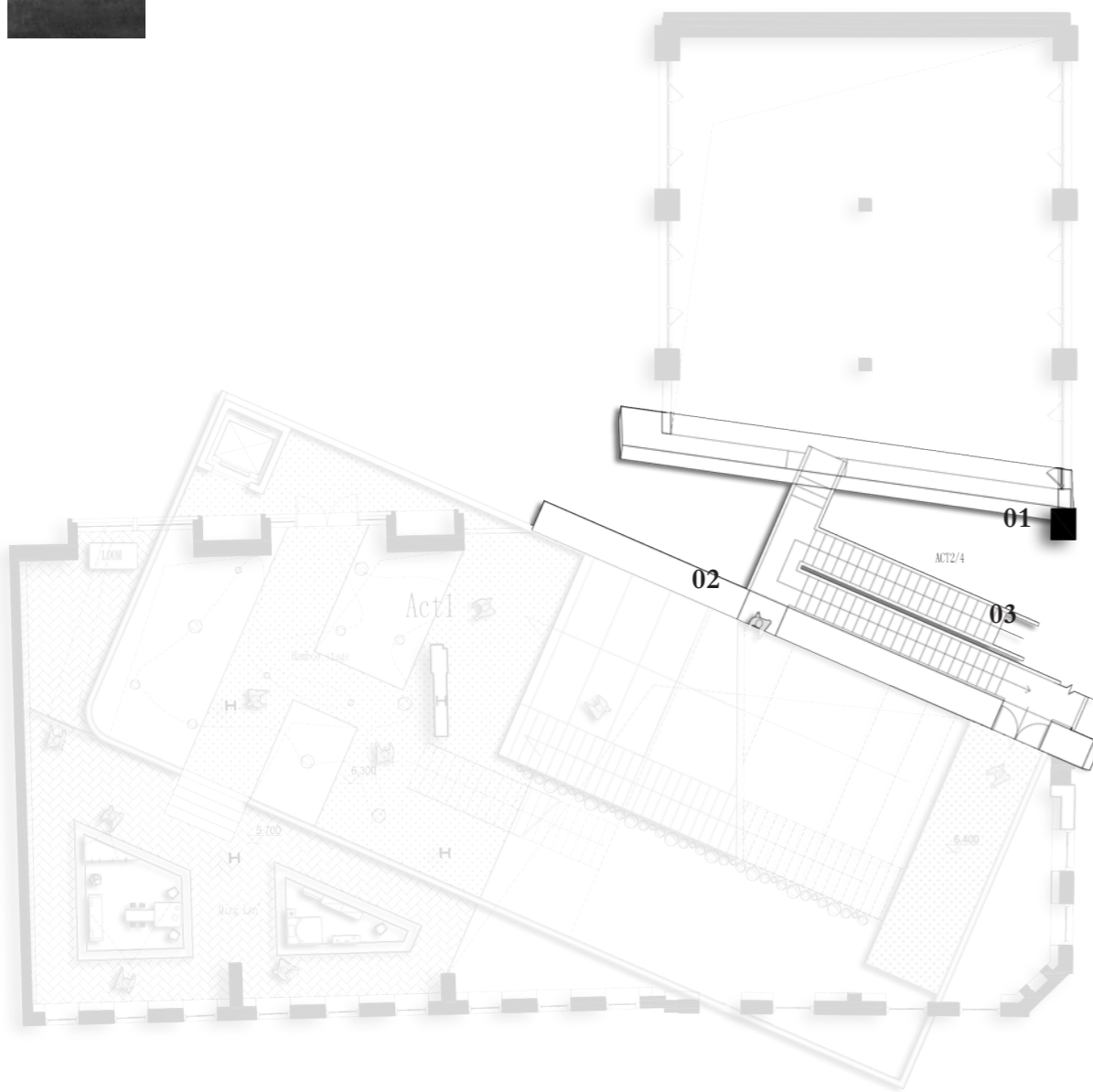

- 01 ACT3Wall
- 02 ACT1Wall
- 03 Stair



THIRD FLOOR 1:200

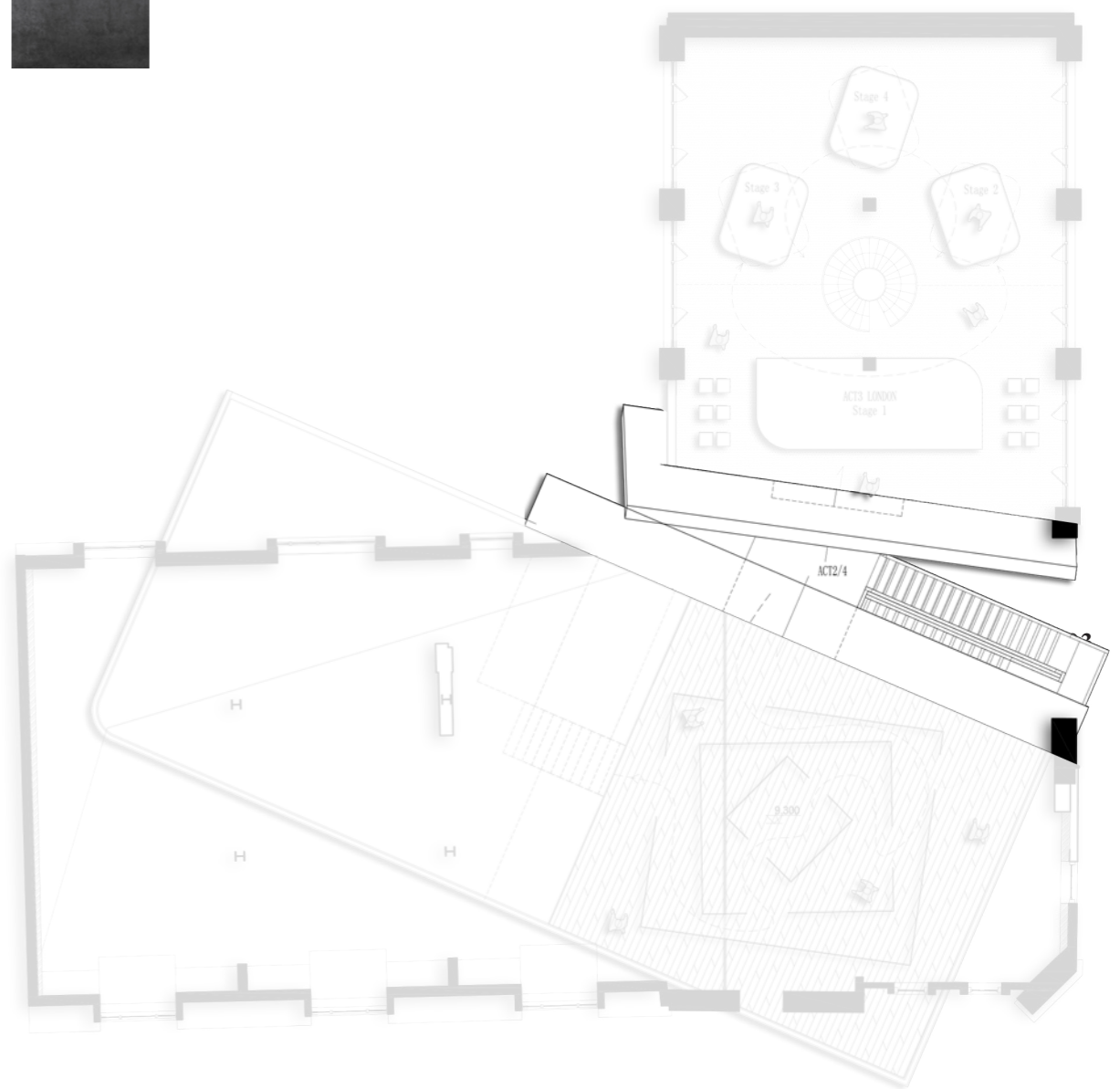

- 01 ACT3Wall
- 02 ACT1Wall
- 03 Stair

ACT 3

*United Kingdom
London Life*

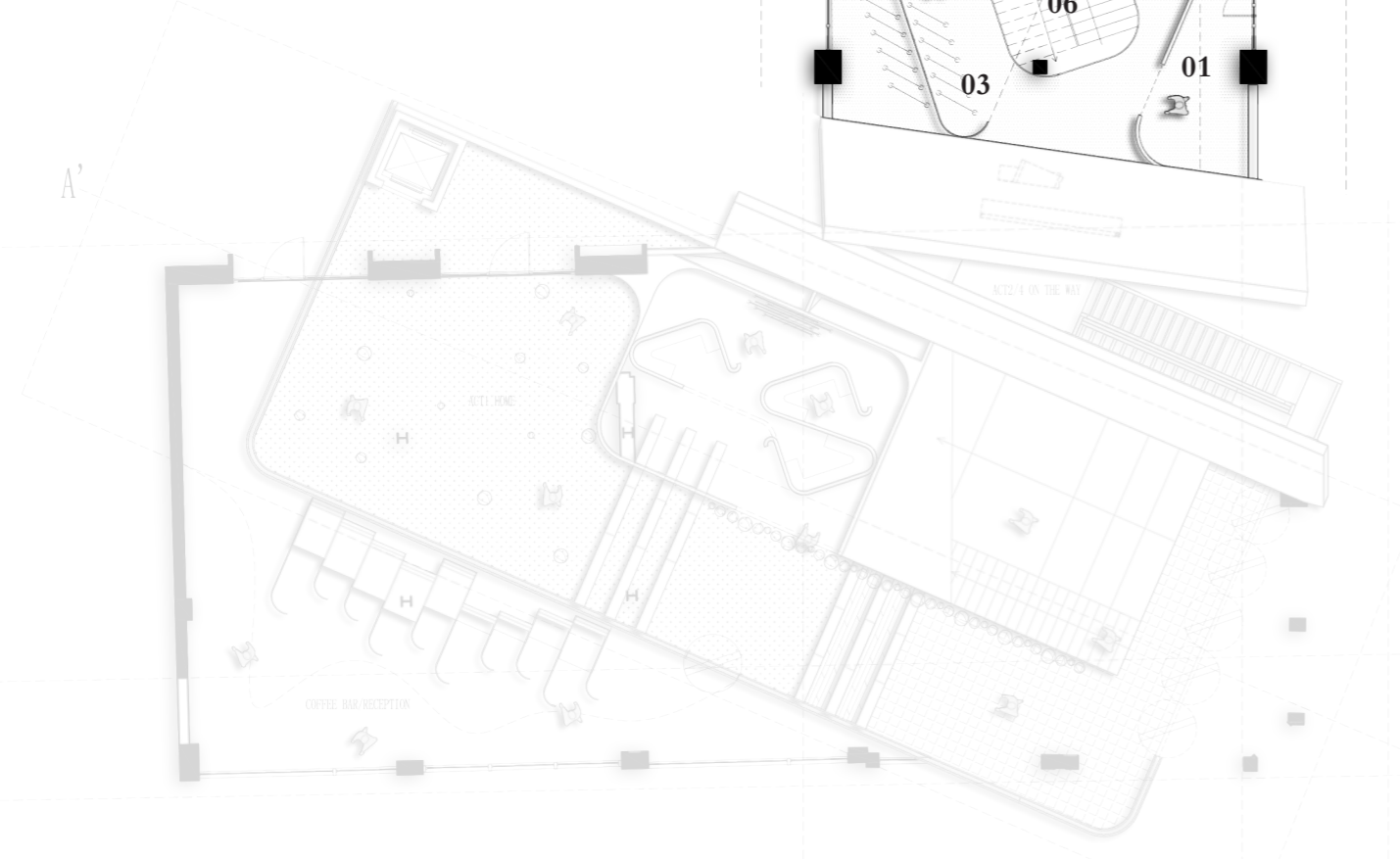
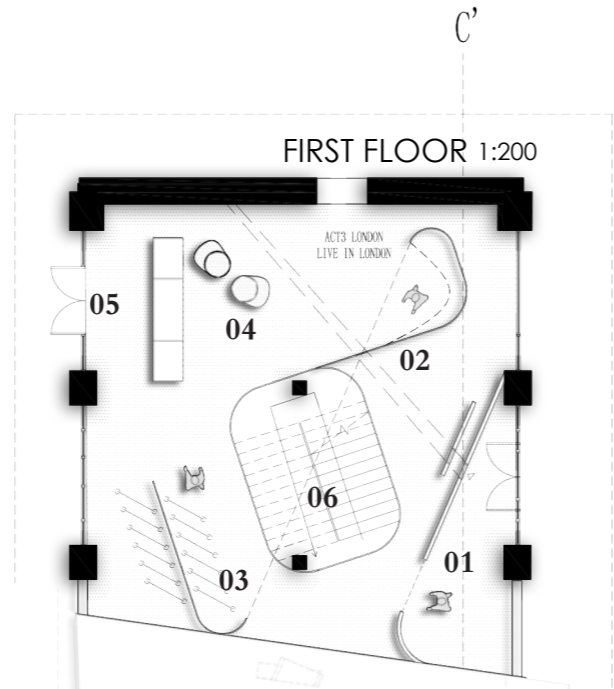
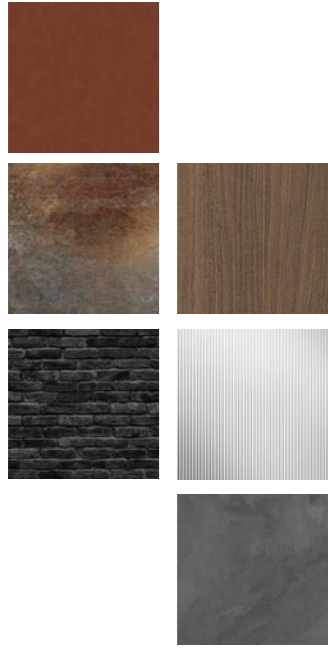

- 01 Act3 Life in London
- 02 Rainy Day Life
- 03 Stairs

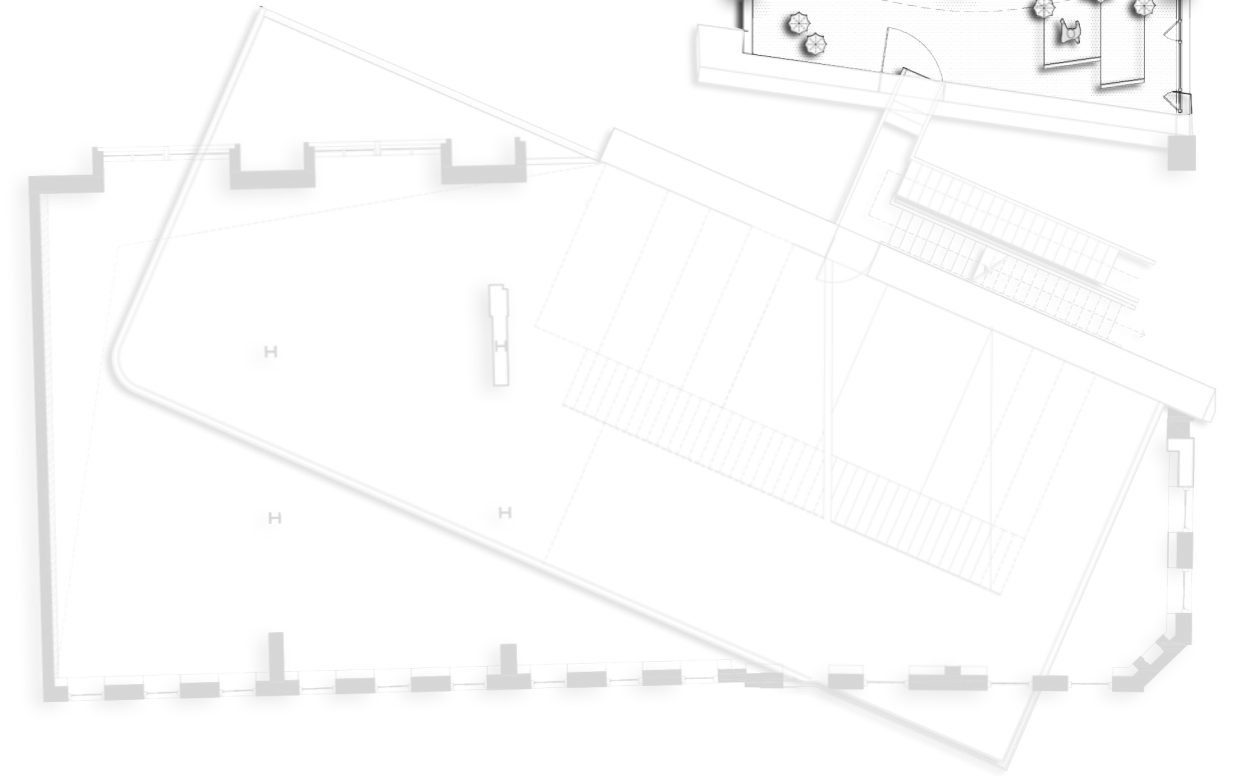
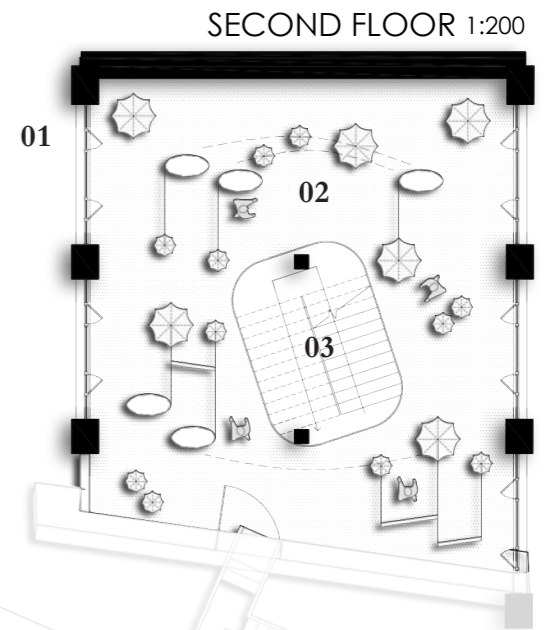
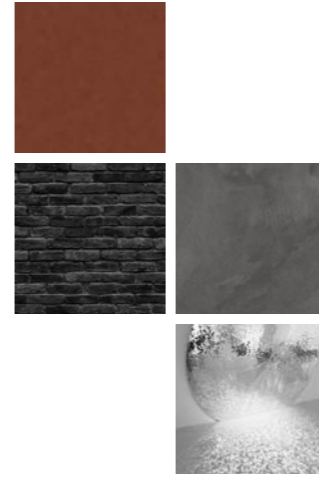

- 01 Act3 Life in London
- 02 Rainy Day Life
- 03 Stairs

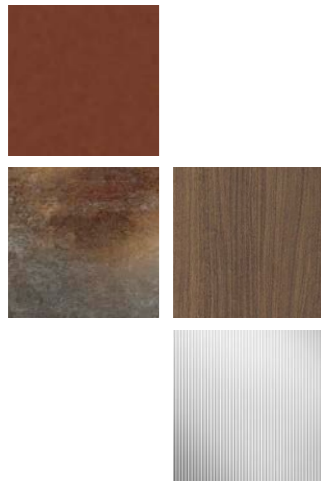

FIRST FLOOR 1:200

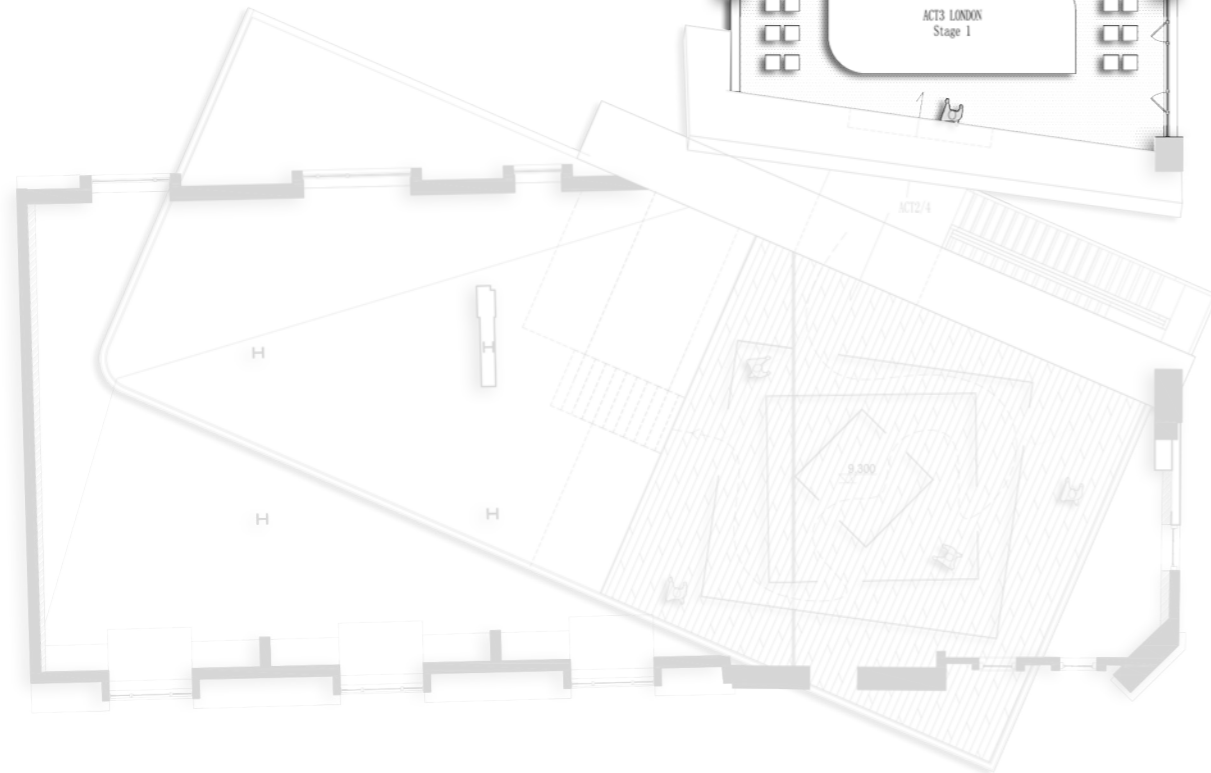
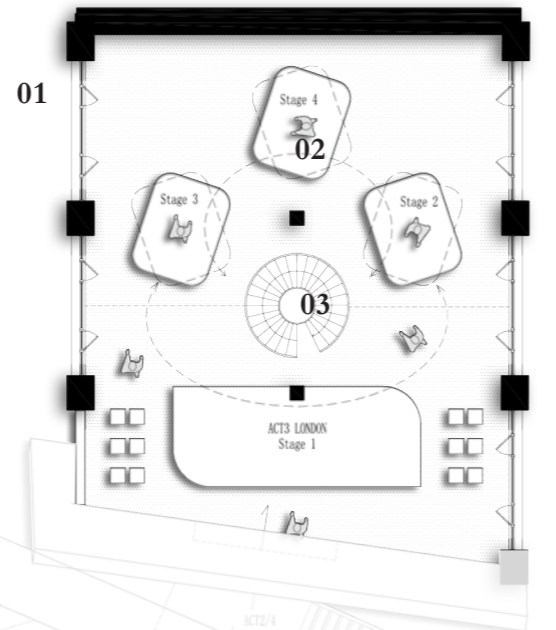

- 01 Act3 Life in London
- 02 Rainy Day Life
- 03 Stairs

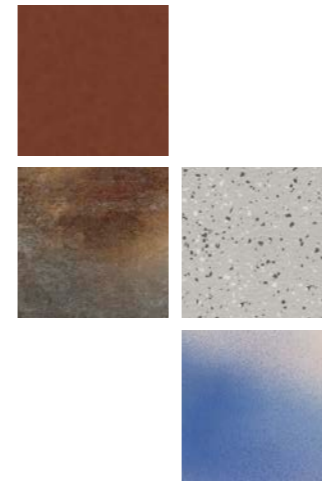

FIRST FLOOR 1:200

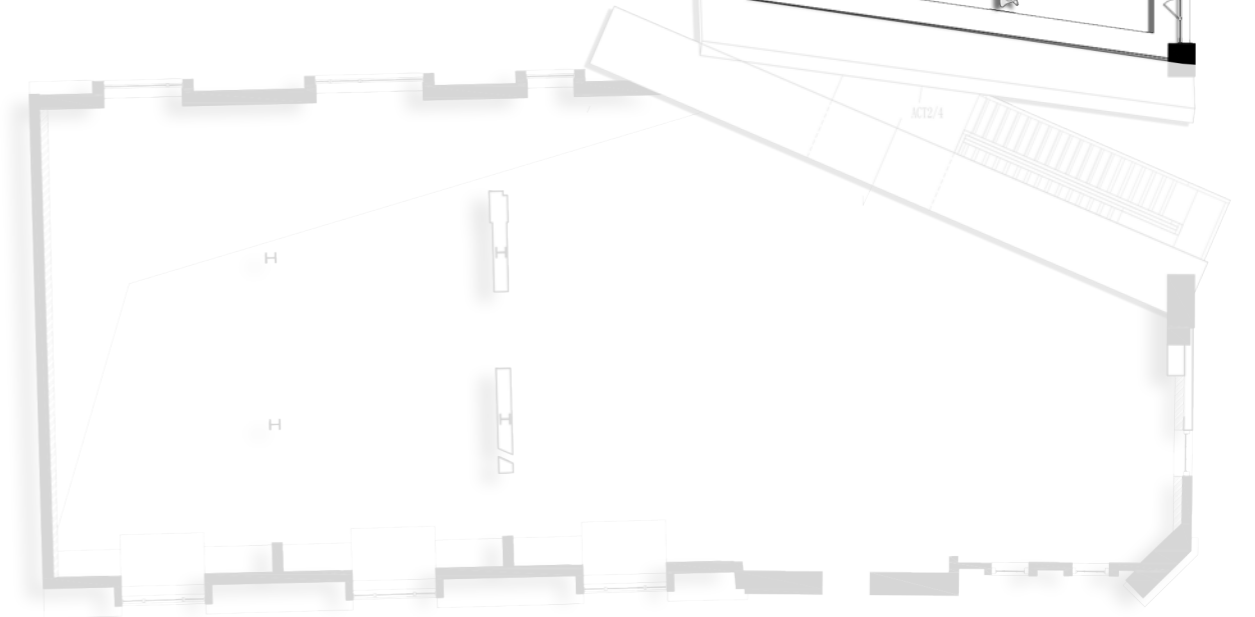
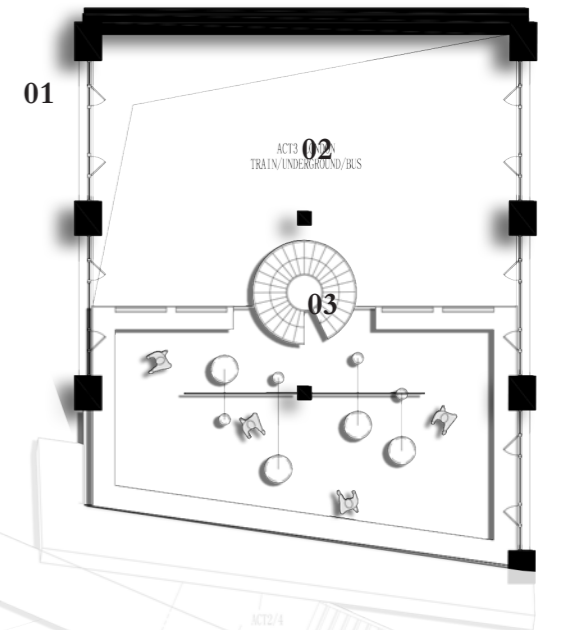

- 01 Act3 Life in London
- 02 Rainy Day Life
- 03 Stairs

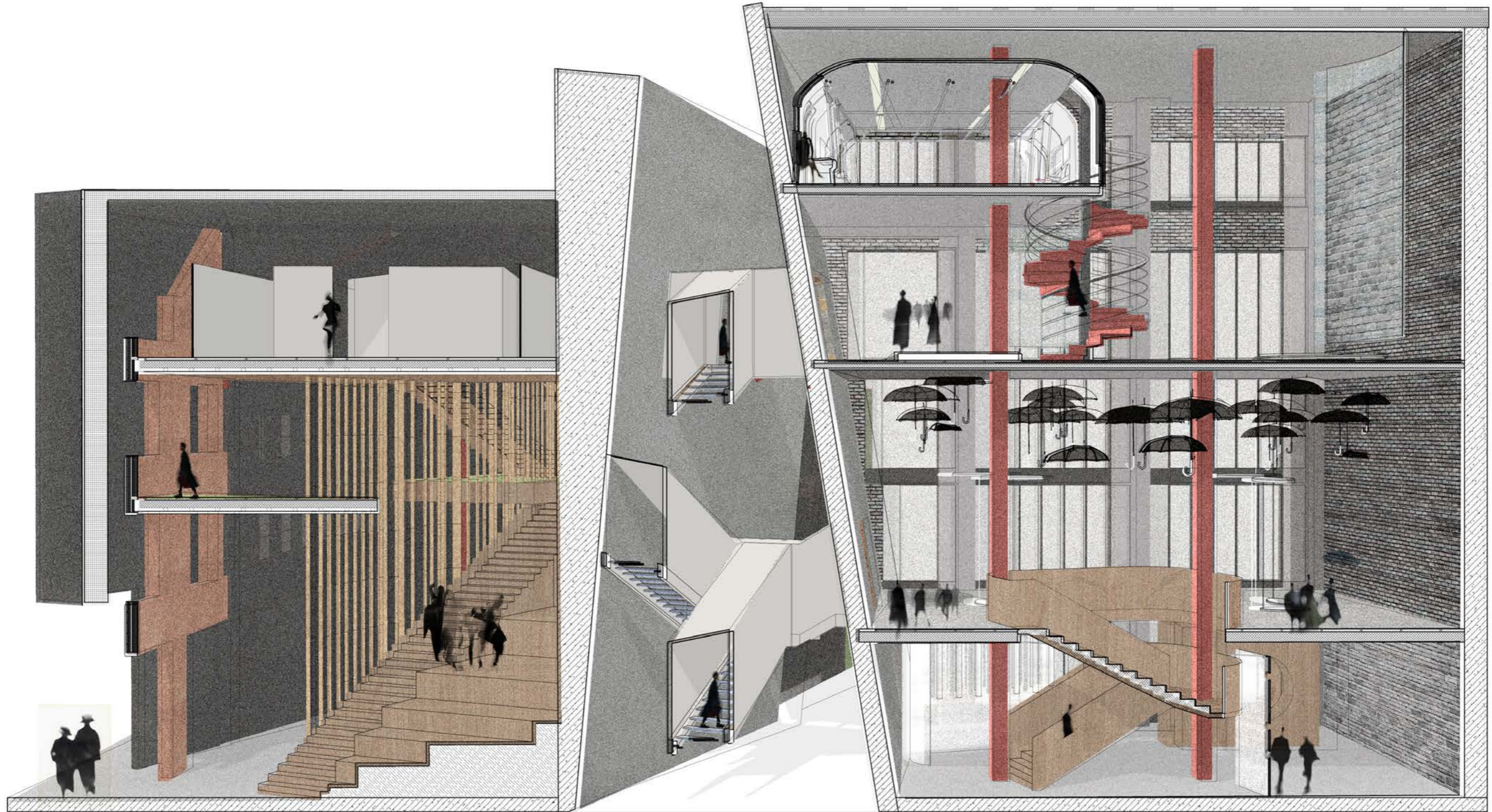



Vsit: Observe the shape of the notes

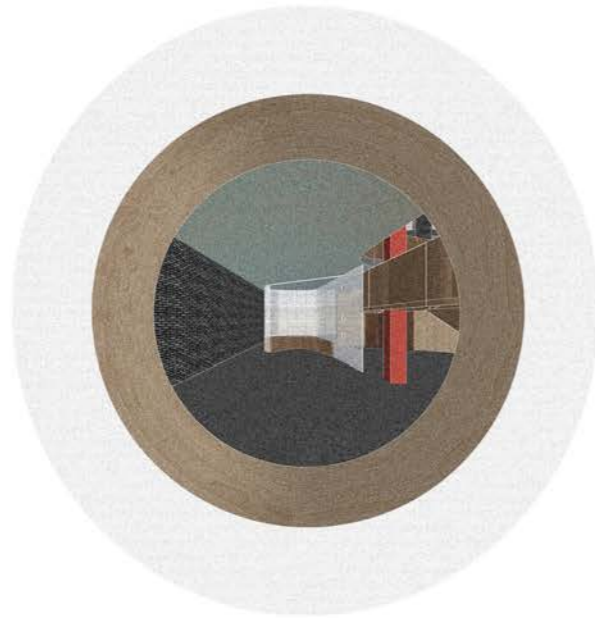

Vsit: Observe the shape of the notes

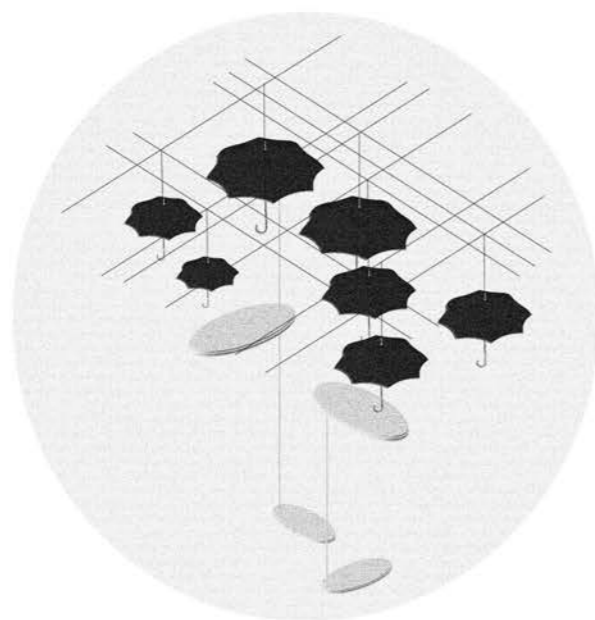

Vsit: The Sound of Rain

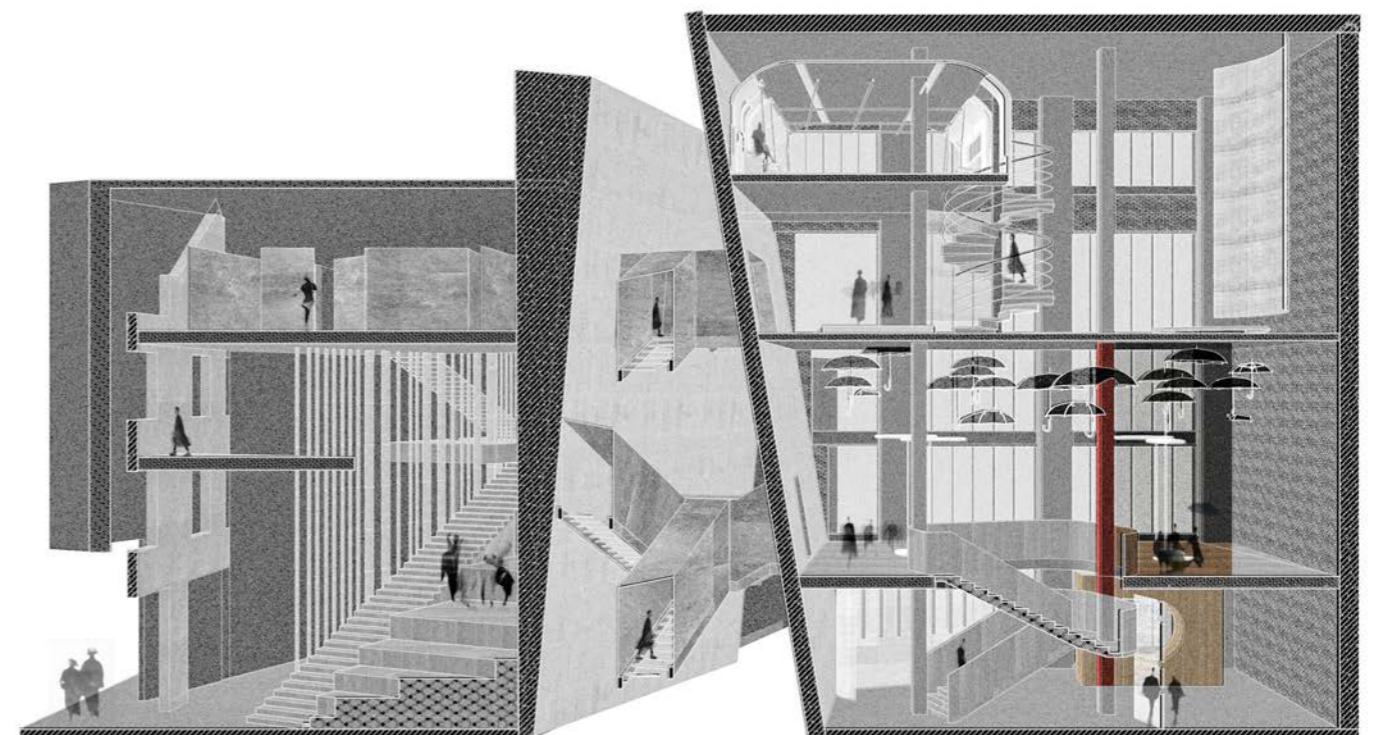

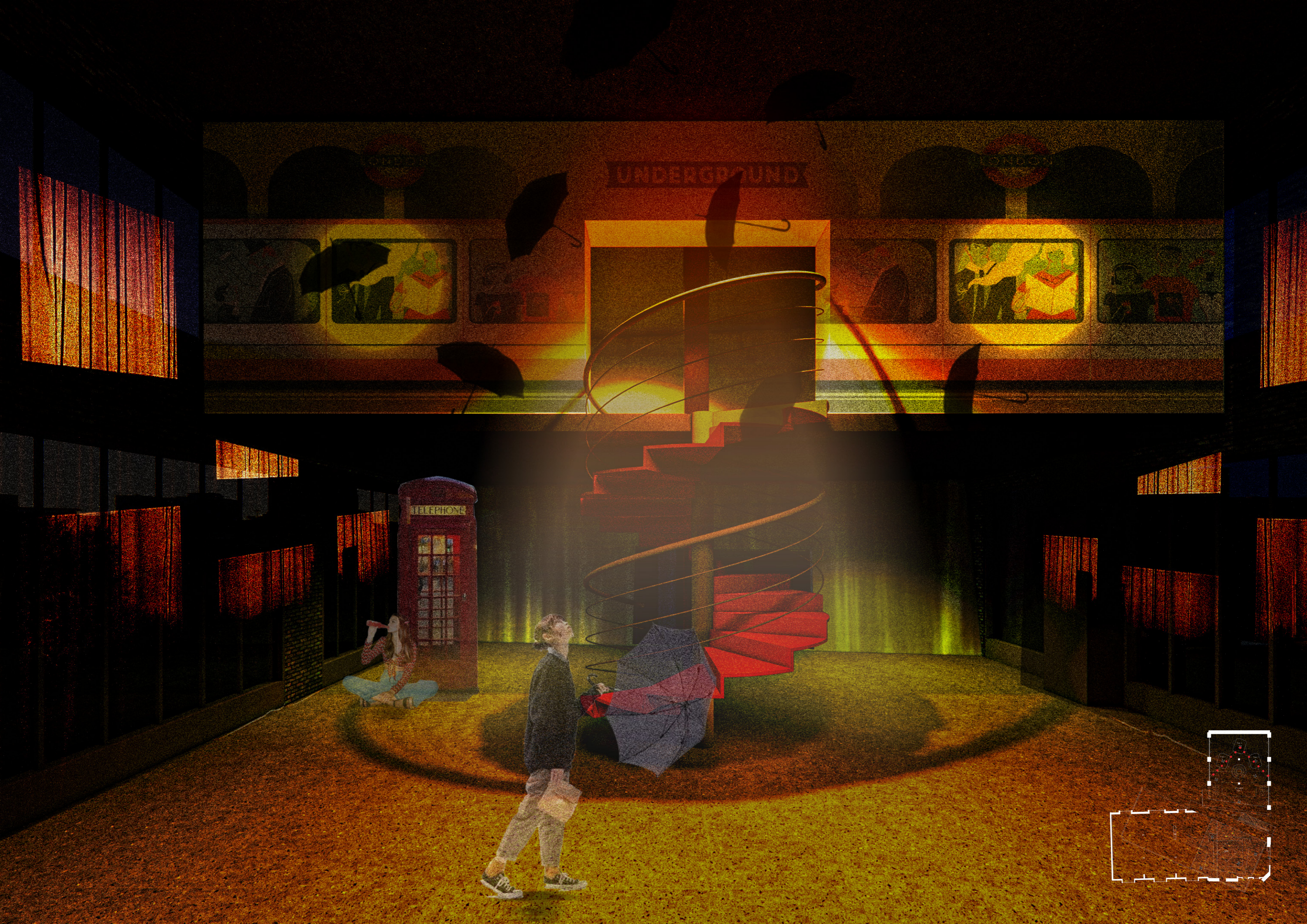

UNDERGROUND

TELEPHONE

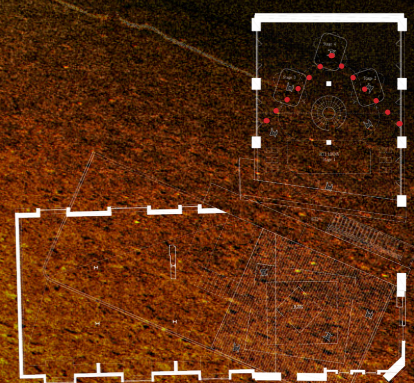

Iteration With Material

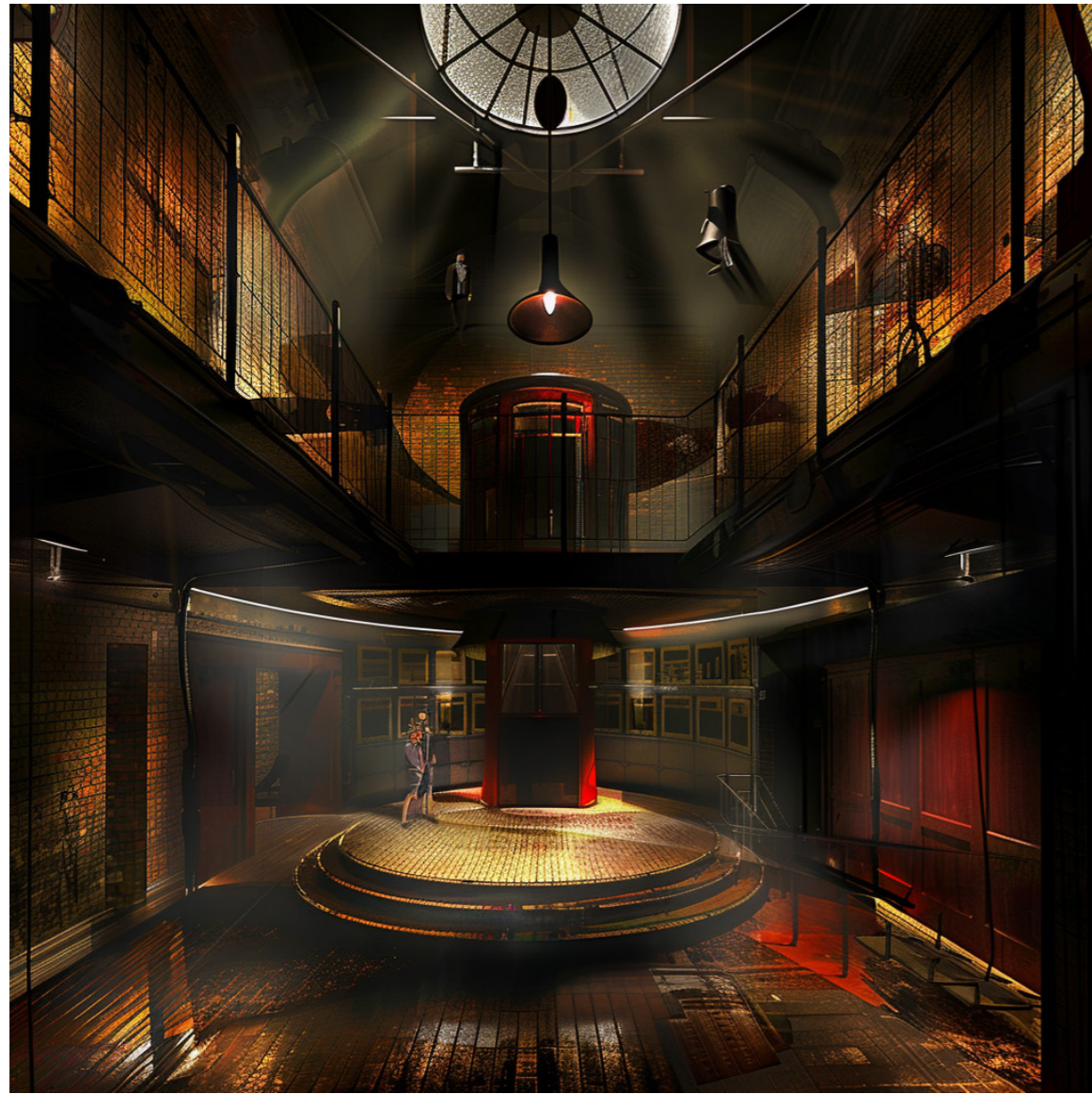

Iteration With Material Individual

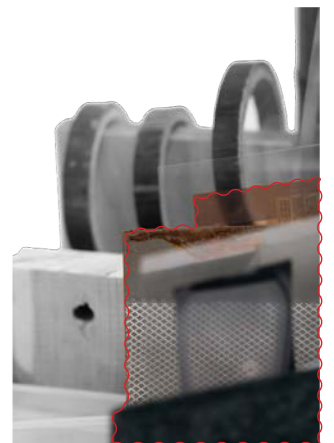



Iteration With Material



Iteration With Material Individual

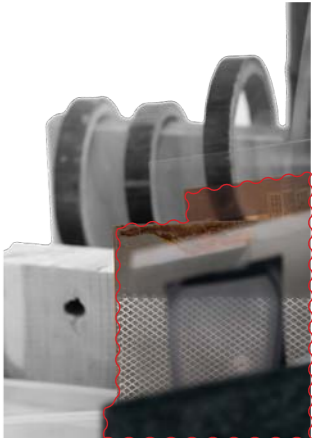



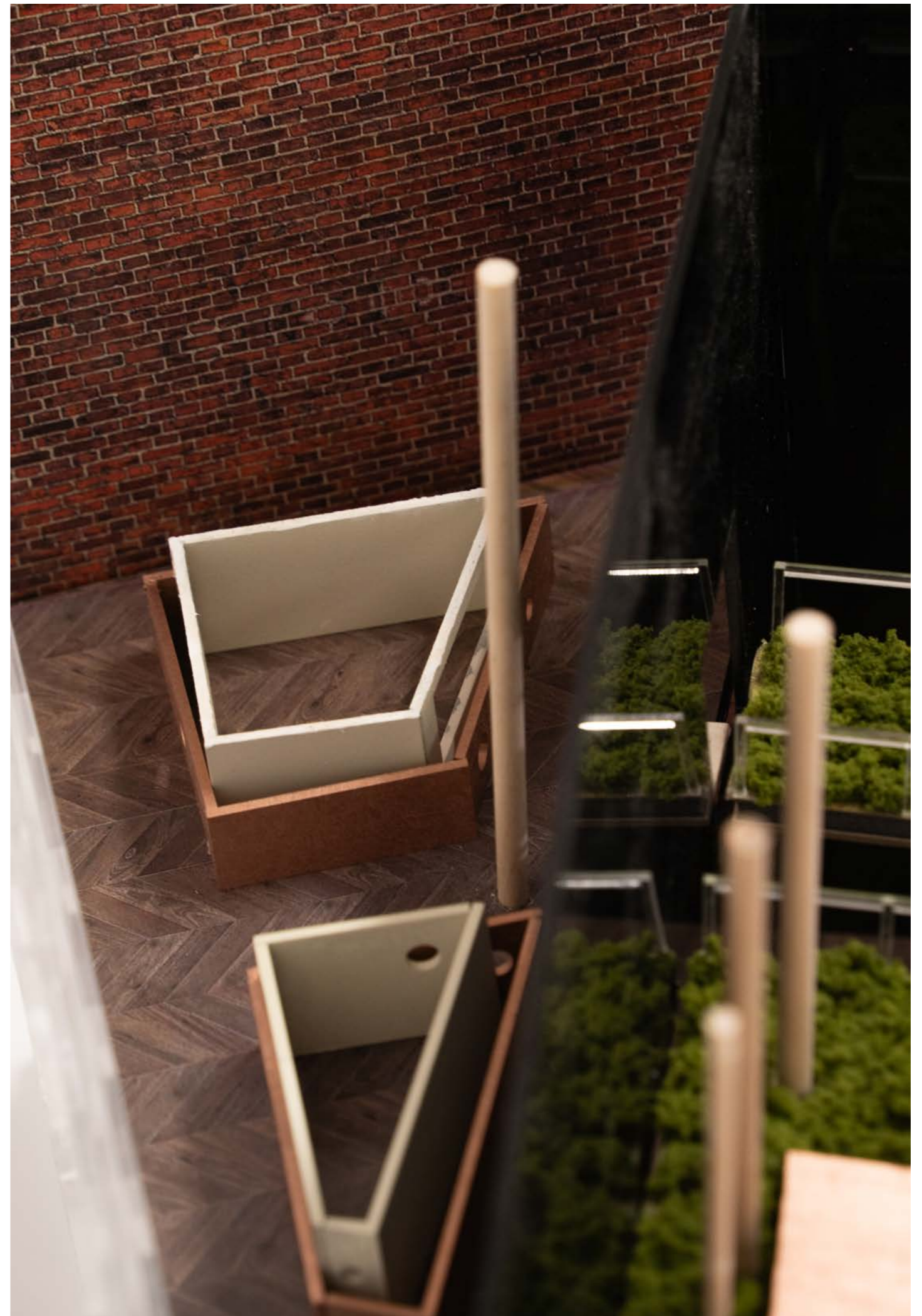





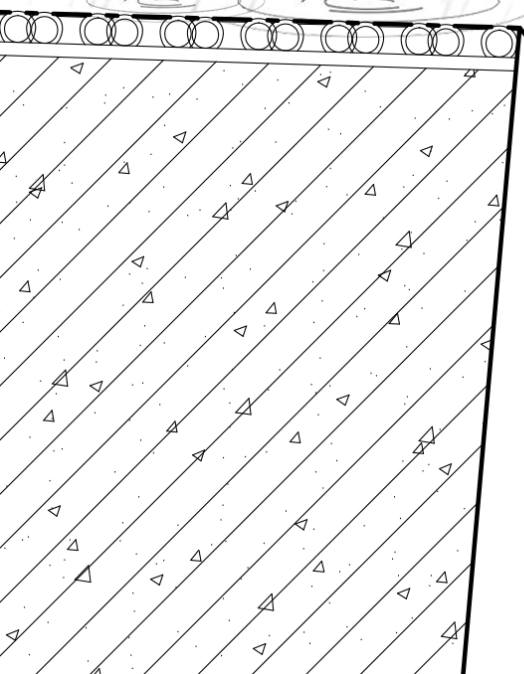
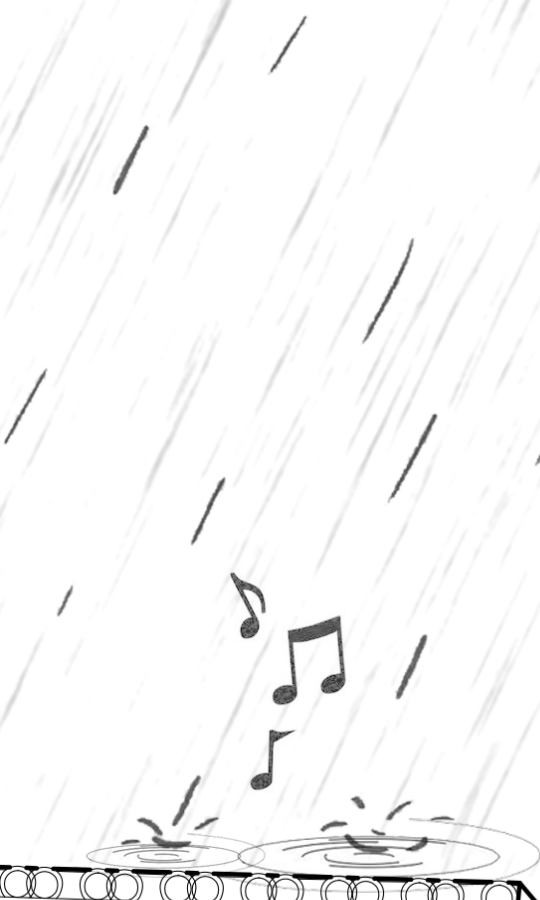
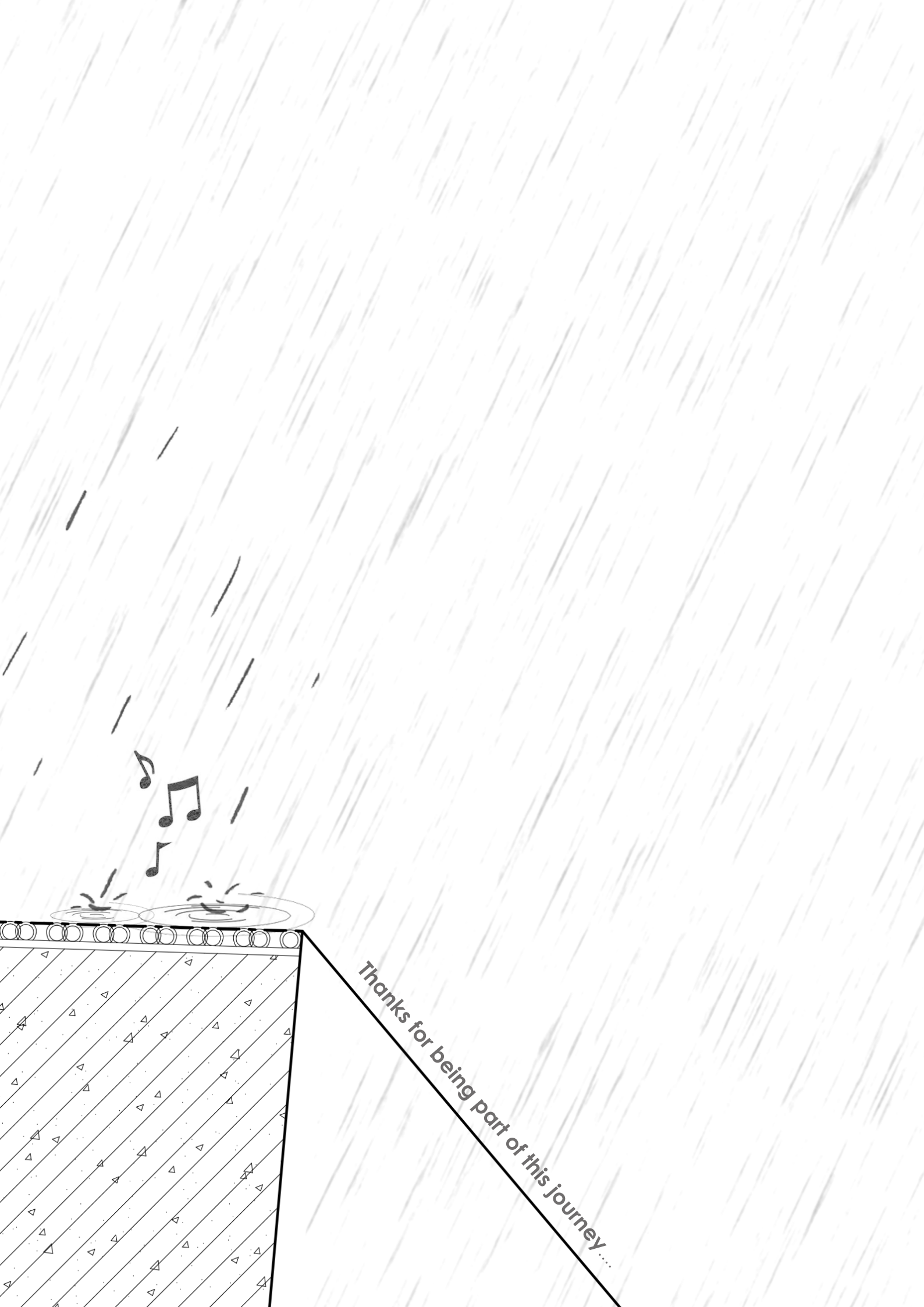

Thanks for being part of this journey....