

Design and architecture are dead.

Pretty variations of the same objects, colors, forms are not enough anymore.

The society needs are beyond aesthetics, function, and big words.

We need to shift from ego-centrism to life-centrism. Rebels of a new era, we fight for a more long-lasting, sustainable, and social-solutions-based future.

We must reuse, reintegrate, retrain, remarket the available resources. A universal and sustainable environment must be created for a healthier and longer life.

Infrastructures, objects and services, both virtual and physical, must be designed for the dreams of the next old and new generations.

# The United Generations

An ecosystem designed to regenerate a community into a citadel  
of conviviality, renewable resources, and shared experiences  
between old and new generations.

Ageing Population Phenomenon

The Perception of Old

Physical Health

Mental Health

Our Parents

Universal Design and Architecture

Isolation and technology

Co-housing

Age Friendly Era

# HOW TO TAKE CARE OF THE OLD

Architecture, design, and  
technology supporting an aging  
population.

In the publication "How to take care of the old" I started observing my relationship with my parents and investigating how my practice could contribute to their and other older people's quality of life. As the population gets older, 3 elements are remarkable: the importance of relationships and the necessity to be involved in the community, and physical and mental wellbeing.



It all begins taking in consideration the quality of life during a lifetime represented here in a virtual three-dimensionalization.

I focused my research on the socio-economical advantages of old and young interactions in a community and I chose to design the hard and soft infrastructure to bring future generations together.

**German centres bring lonely older people and children together**

The multigenerational houses offer an alternative for older people who feel lonely and young families who need support

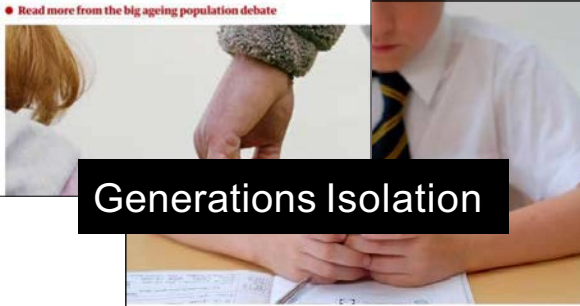

**Generations Isolation**

More than 80% of adolescents not active enough, warns WHO



**'It's like being reborn': inside the care home opening its doors to toddlers**



**Social Activities**

**Food trends**  
**Food is where the generation gap is wide**

Boomers cook one way, Generation another - and the best generation knows more about mince than anyone else on planet



**LIVE CLUBS**

**CNN health**

How a wood starting a r mental hea

**mosaic**

By Alex Riley, Mosaic

Updated 0920 GMT (1720 HKT) October 16, 2018



**Partnerships in practice**  
**Generation game: what can students and the elderly teach each other?**

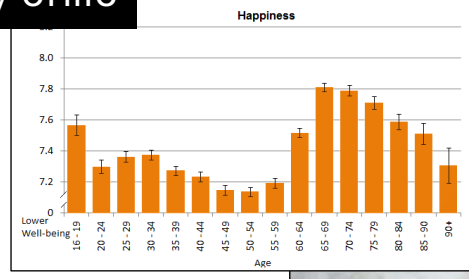
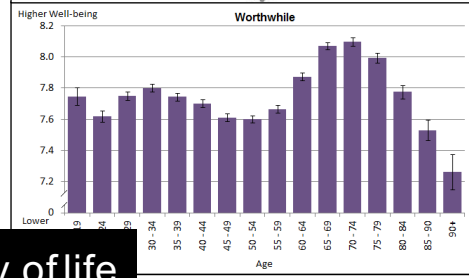
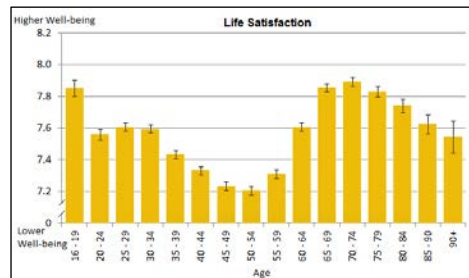

What is happiness?

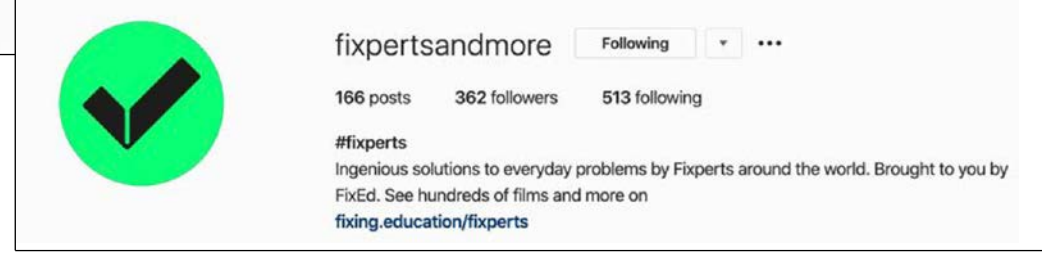
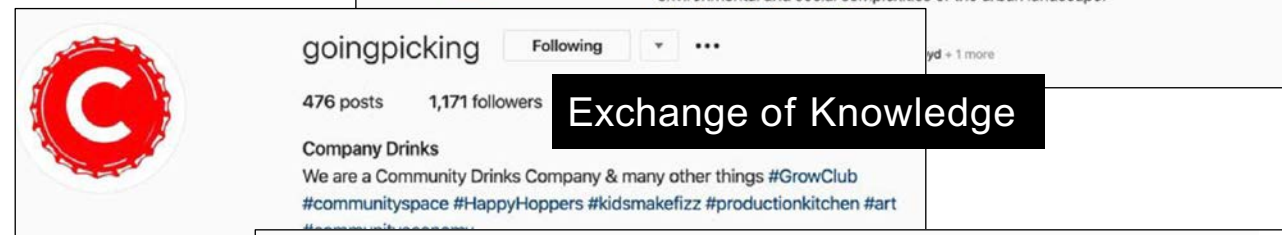

Kent community project bringing young and old together



**All under one roof: the rise and rise of multigenerational life**

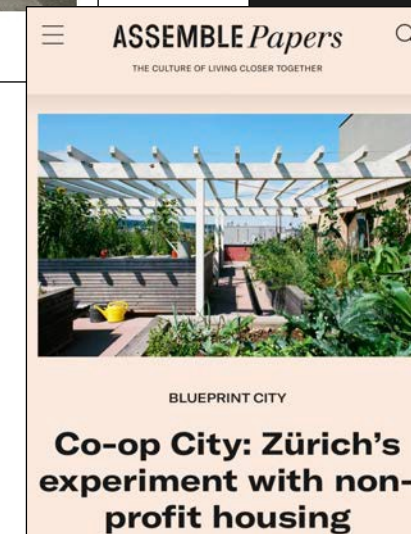

**Co-op City: Zürich's experiment with non-profit housing**



**Communities**



**WHY SOME DUTCH UNIVERSITY STUDENTS ARE LIVING IN NURSING HOMES**

What students can learn from time spent in care homes

14/10/2019  
Call Time: 11:15- 11:23

L. is doing alright, she doesn't feel much lonely for now. - She has a carer on Wednesdays who cleans and shops for her. - She does chair *exercise* in the mornings, she cooks, she reads, sews, knits watches TV and listens to the radio. - She had two daughters that call her on the phone (she doesn't have any digital device) - She calls classmates from the exercises and lunch club and Mery in the same building. - She is asking if there are people that can clean, fix the garden, she will try to call agecare.

22/11/2019  
Call Time: 10:15-10:20

M. is coping with living alone. - She has enough food for herself. - She is also exercising (when she feels like it) doing the same chair exercises at KLS. She is quite busy cooking, cleaning, and teaching (?). Call her a little later next week.

22/11/2019  
Call Time: 10:50 - 11:10

L. is doing well, sometimes in pain for her back pain but taking tablets and stretching, chair exercise. She cooks for herself, knits socks, reads *An Improbable Life: The Autobiography*. She knitted her cardigans but not anymore for arthritis. She did it for passion and learned it going to a class. Her daughters visit her sometimes but they don't come often now. She has 4 grandchildren who talk to her by phone only. The medicines are delivered every Saturday by the doctor. She goes to the garden in her estate. KLS delivered yesterday and today a meal. She asked where I was from and we talked about her home country, when she moved to the UK and when she went back to visit relatives in Jamaica. Hard to travel now because she is diabetic and etc. Sometimes she feels lonely but she keeps in touch with friends from the estate. They ring each other.

07/12/2019  
Call Time: 16:35 - 16:50

We introduced each other. He told me he has coronavirus but didn't go to the hospital yet because his health didn't worsen. He also has cancer and he has a stomach surgery recently. He is 65 years old and has a Filipino girlfriend aged 56 in the Philippines who is stuck at home (and she is worried that she won't come back to the UK). We talked about lockdown measures, travel restrictions there, and compared them to Italy and the UK. We talked about people that in this situation do good or bad for society. He seemed a bit down but positive for the future.

15/01/2020  
Call Time: 16:00 - 16:30

He is doing ok. He doesn't do much all day (he can't push his body too much because of his disease of the nervous system (he explains to me scientifically). He says he now understand more why he can't do many things "It is one piece of the whole puzzle". I need to take a long rest in between doing one thing and the other otherwise I faint or fall. He mostly fixes, cleans, and organizes the thing. He lives with daughter (Carehomes be professional, she has to switch on and off due to the tragic conditions) and husband which help when they are home and they do groceries. He has the garden and 2 dog staffies to take care of. He brings them around the block. He has a carer that make sure he has proper meals and drinks. He also goes to the supermarket even though the queues are a nightmare so he goes to smaller shops. I asked him if he had access to technology but he said he finds it hard to approach because of his dementia. Not really tech-savvy, it is hard for him even to write emails (because he keeps going back forgetting what he wrote). He finds hard to even read newspaper sometimes. He talks about his condition pretty freely since he had it for a long time. He is drawing a lot in watercolors: dogs, landscapes, buildings, grounds, an aircraft Queen carrier. But he prefers to draw architectural perspectives: straight lines, angles. He kept repeating that hopefully, everything will go back to normal soon and back to the center.

13/02/2020  
Call Time: 17:35 - 18:10

Exercise, painting (crayons and paper). Volunteers just brought some dinner: minced beef, pasta, pieces of cake, bananas. Reading this book about Trevor from Trinidad. Banana, lam (fruit), pineapple, mango. Learning Jamaican and know much about each other because we don't visit the other parishes. They used to have trains after war (after its independence). Only taxis. More than 60 year in the UK, in Leeds nursing 1969. I bring my kids to Jamaica to introduce them to the family. Very poor country.

09/03/2020  
Call Time: 10:50 - 11:10

Car speeding and social distancing are similar things: people don't think at the risk they are creating. Talking about my thesis project, he said he sounds like KLS but at a bigger scale. Girlfriend in the Philippines is worrieand boy at the police, daughter in Saudi working as a nurse but now a dentist. They can't be together anymore. Lockdown should be more strict. Generations of me me me egocentrism. Painting by numbers not arrived. Sending money through the company. Remembering the bank holiday end of the war. Nice to have somebody to getting things out of my chest. It is nice you give me the opportunity of talking together.

12/04/2020  
Call Time: 16:55 - 17:09

He is very active (85). He seems very uplifted and full of energy. He told me he is fully independent. He does everything in the house and his hobbie is crosswords. He is a cruciverbalist, he does the most difficult ones. He told me he usually go to bed at 7PM and wake up at 3AM but now he sleeps till 5AM. He told me a proverb: "Early to bed and early to rise, makes a man healthy, wealthy, and wise". I found he very funny and strong in character.

30/04/2020  
Call Time: 17:25 - 17:30

Chronic back problem and use a cane. Mobility is limited. Attending pain killers. No operation because no any good. Bus anywhere every day. Aged almost 86. Walk wimbledon,

I started volunteering weekly in a community center which helped me understand the needs, challenges and dreams of older people. To learn form them. To talk to them. To be patient. To be respectful. To observe how a community center works, what kind of activities are offered, when, and why.

21/05/2020  
Call Time: 17:00 -17:20

fill out forms for pensions. Carer come in the morning to bathe, dress, cream, massage feet and legs, hot bag for back pain and lunch for cooking hot meals and drinks. She psends even more time to check on him. She makes sure he is doing for well. She buys meals for him as well. She doesn't want any extra money. She gives extra care. She is like a little angel. Most come and do what they need to do. The carer would like to go everyday. She does He fell down the stairs, just bruises on the arms and knees. 30 tables/day. Still in pain but it is getting back to normal. Take a long time to get down and he felt the shoulder get out. Fine to pick up a bag but not scrubbing the nose.

09/06/2020  
Call Time: 16:30 - 16:55

KSL food delivery: cooked and groceries, he was very grateful. Didn't change much of last week. Pretty weak as always but didn't get worse. He also received paint by numbers and starting to paint a tree. We talked about my thesis project and about stress reminding that here are people that are dead that would like to be a bite stressed. He liked the Italian president say "all we need is pray". He is happy that KLS staff tell him "We are all worried about you". He feels taken cared of. He asked when we staff talk again to sayhi.

Creating

Teaching

Living

Working

Playing

Praying

Talking

Learning

Naturalizing

Cooking

Exercizing

Performing

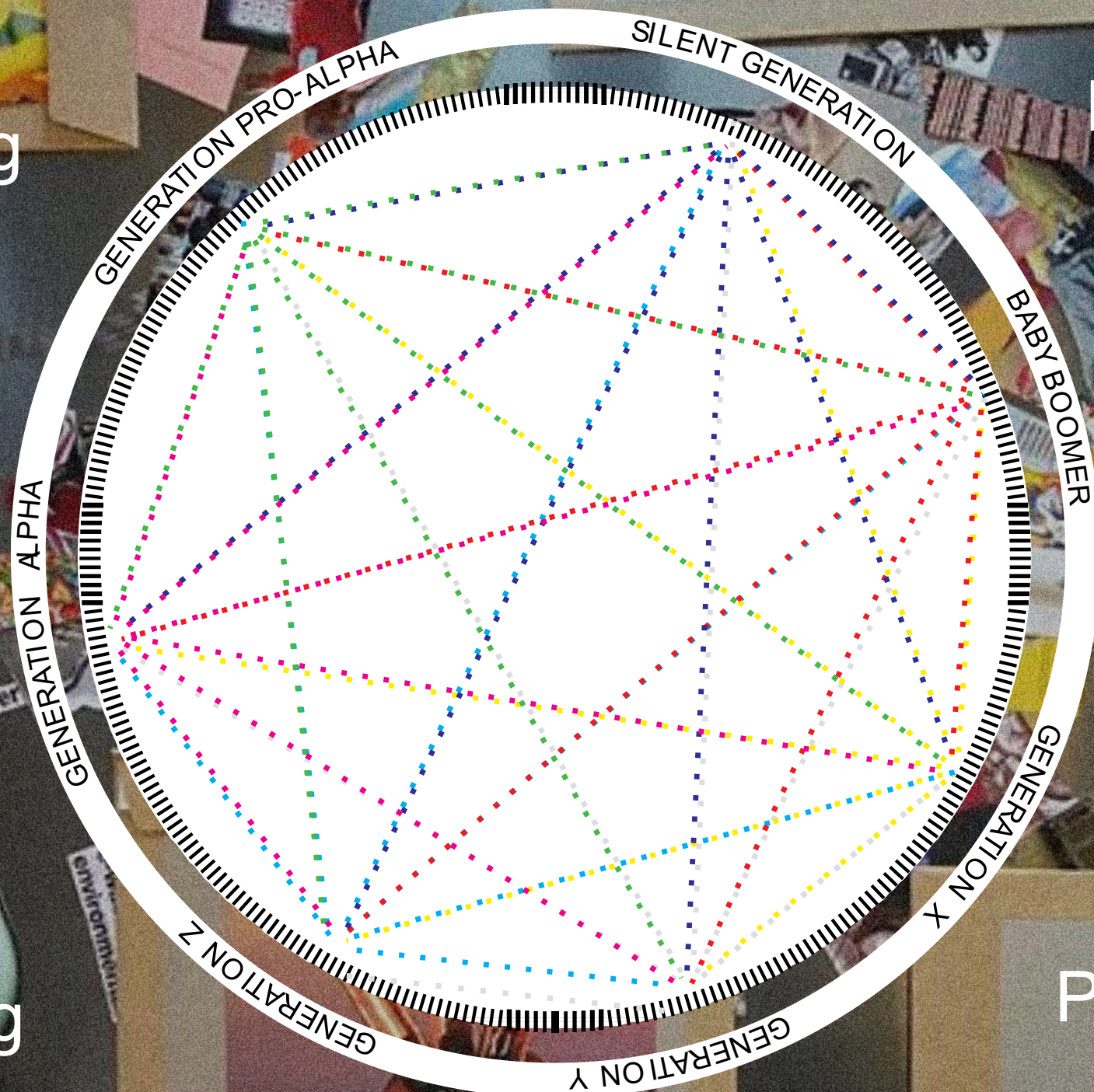

Research, interviews, and workshops have lead to these common activities among generations.

Each activity (soft infrastructures) can happen in one or many spaces (hard infrastructures).

### Gardening

Vegetable Flower Horticulturing

### Farming

Chicken/Duck Farming, Robot-Pets Caring

### Cooking/Eating

Fermenting, Nano-food Culturing, Decorating

### Teaching

Reading, Suitcase Gaming, Benching

### Playing

Cards, Ipad Gaming, Brain Games

### Praying

### Creating

Decoration, Knitting, Carpentry, Ceramics

### Shopping

Groceries, Antique Market

### Writing

(poetry, books)

### Performing

Singing, Dancing, Acting, Playing instruments

### Naturalizing

Walking, Nature Collecting, Recycling

### Exercising

Chair Exercising, Sport Games, Stretching

### Digitalizing

Technology Workshop, Social Networking

- Park
- Garden
- Greenhouse
- Farm
- Warehouse
- Factory
- Laboratory
- Kitchen
- Restaurant
- Food Truck
- Home
- Theater/Auditorium
- Public Square
- School
- Church
- Office
- Community Center
- Library
- Bar/Pub
- Gym/Sport Center
- Pool/Spa
- Art Center
- Museum/Gallery
- Workshop
- Shop
- Market
- Club/Disco
- Carpark
- Street
- Clubhouse
- Playground

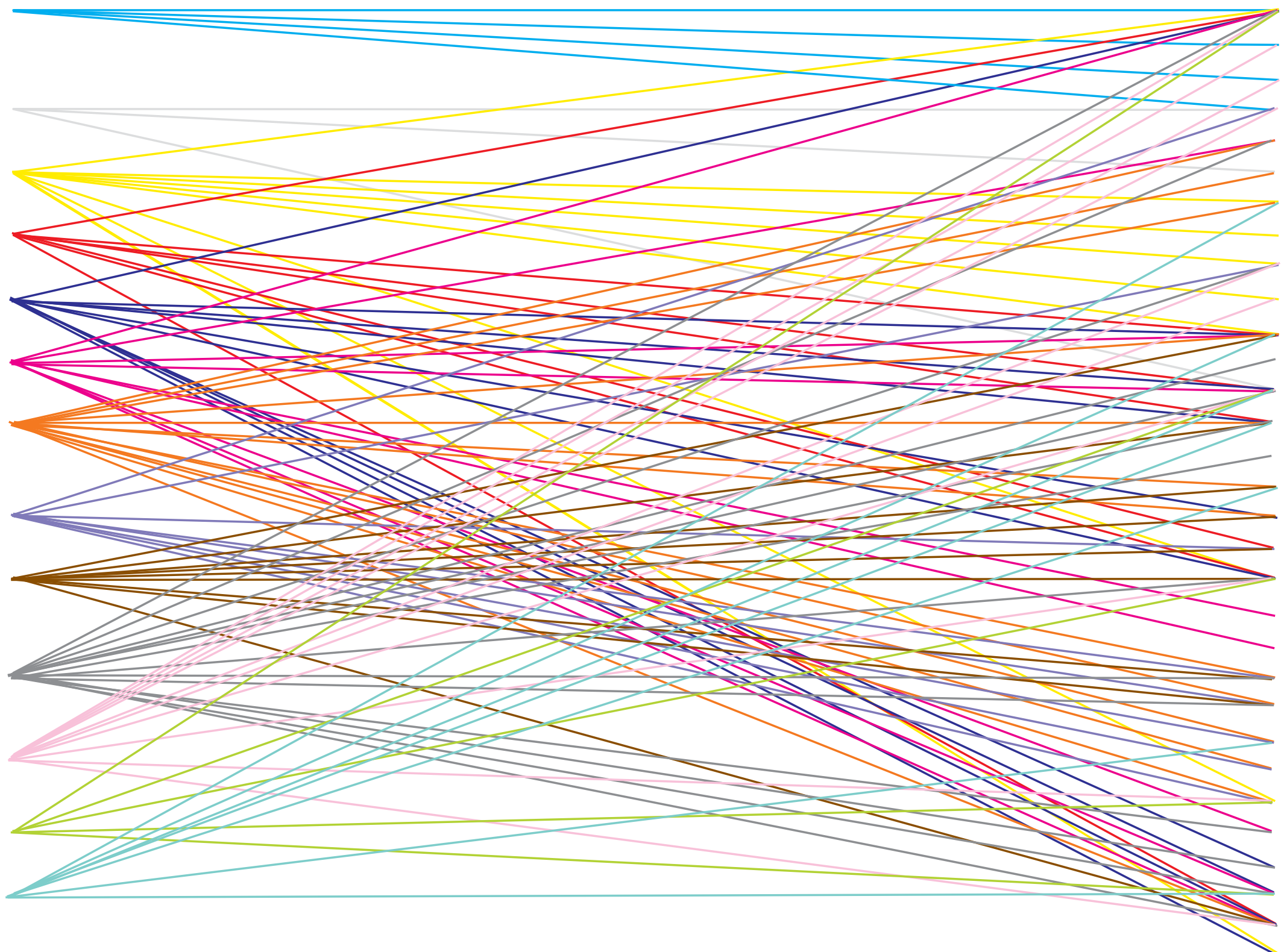

In a time when the older population needs to be reconnected more than ever with the younger one, I propose to go back to the Arcadian archetype where community, sustainability, and simplicity are the assets for a prosperous living.

Simplicity

Sustainability

Community



Arcadia is a vision of pastoralism and harmony with nature. A poetic space associated with generous natural splendour and harmony. Arcadia is a Garden often inhabited by shepherds. The inhabitants of this region live close to nature, uncorrupted by civilization, and virtuous.

Arcadia is a vision of pastoralism and harmony with nature. A poetic space associated with generous natural splendour and harmony. Arcadia is a Garden often inhabited by shepherds. The inhabitants of this region live close to nature, uncorrupted by civilization, and virtuous.



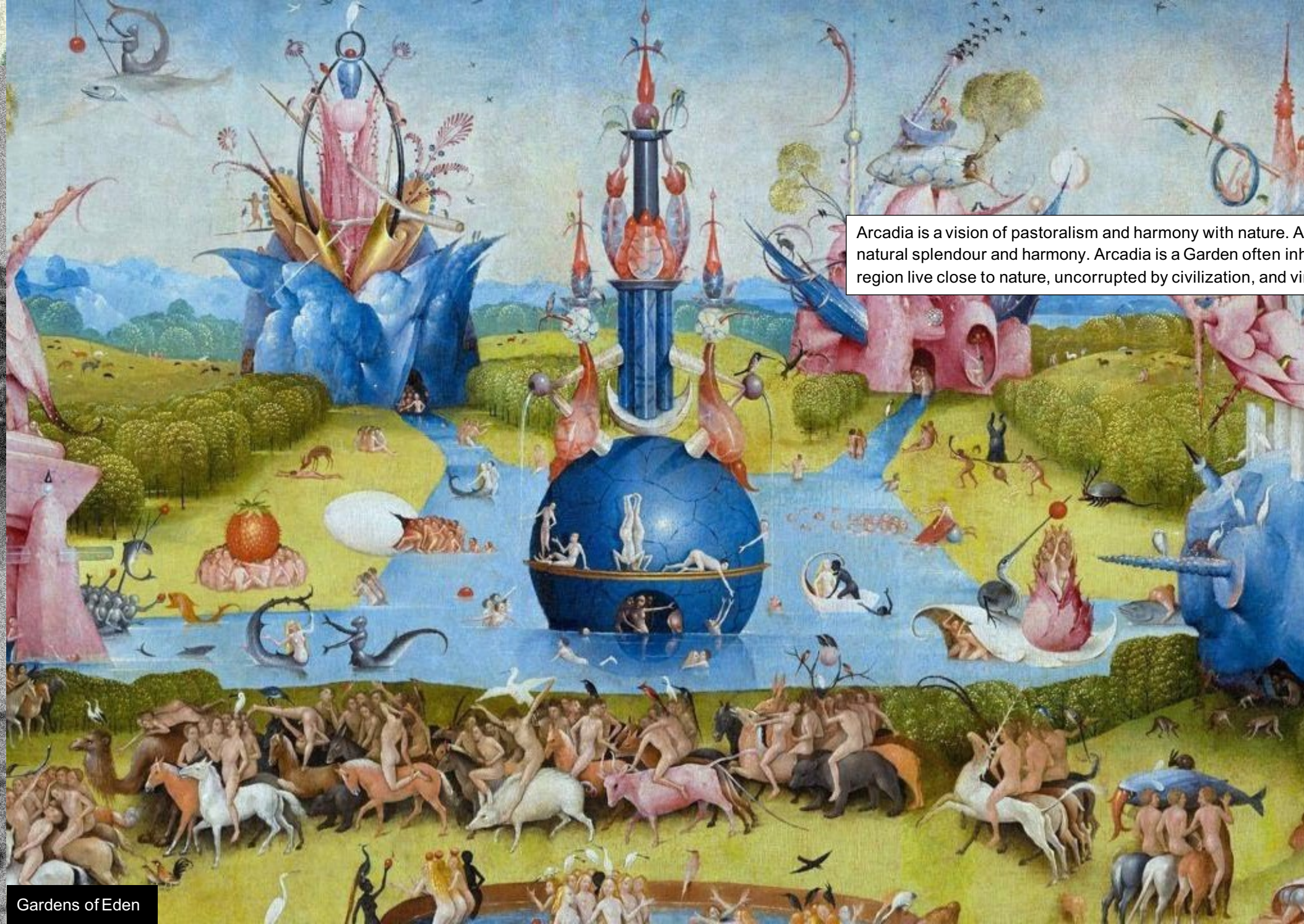

Arcadia is a vision of pastoralism and harmony with nature. A poetic space associated with generous natural splendour and harmony. Arcadia is a Garden often inhabited by shepherds. The inhabitants of this region live close to nature, uncorrupted by civilization, and virtuous.

Gardens of Eden



Arcadia is a vision of pastoralism and harmony with nature. A poetic space associated with generous natural splendour and harmony. Arcadia is a Garden often inhabited by shepherds. The inhabitants of this region live close to nature, uncorrupted by civilization, and virtuous.



Gardens of Eden

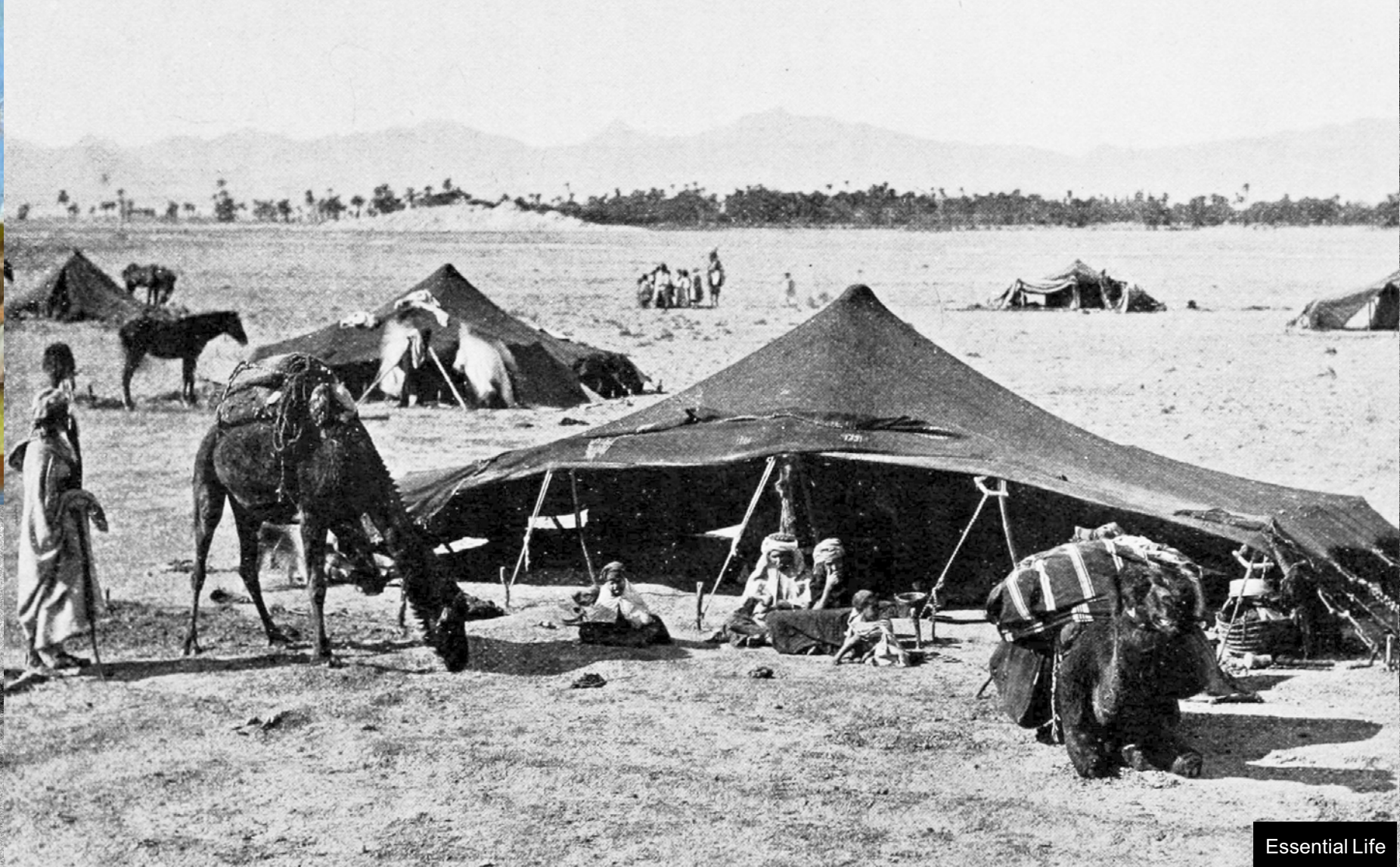

Essential Life

The CourtLife



Gardens of Eden



Celebration of nature

Arcadia is a vision of pastoralism and harmony with nature. A poetic space associated with generous natural splendour and harmony. Arcadia is a Garden often inhabited by shepherds. The inhabitants of this region live close to nature, uncorrupted by civilization, and virtuous.



Essential Life

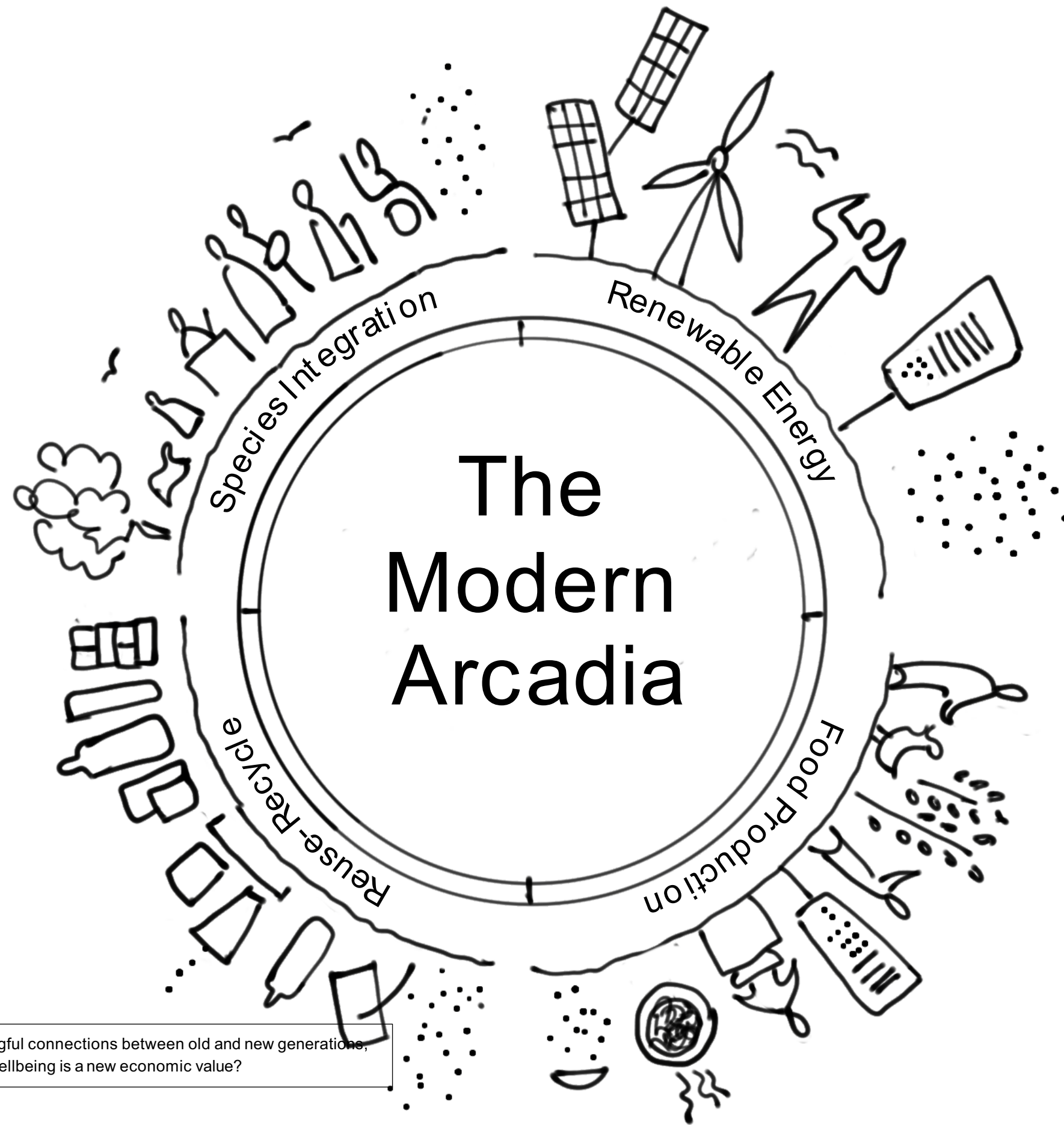

Could Arcadia be a contemporary living model to create meaningful connections between old and new generations, based on a sustainable, integrated and caring economy where wellbeing is a new economic value?



This is the Golden Lane Estate, the city in the city. A urban microcosm designed by Chamberlin, Powell and Bon to promote the modernist principles of wellbeing and social living. An example of 1960 utopian architecture. The perfect site to test the flourishing of a more intergenerational community.

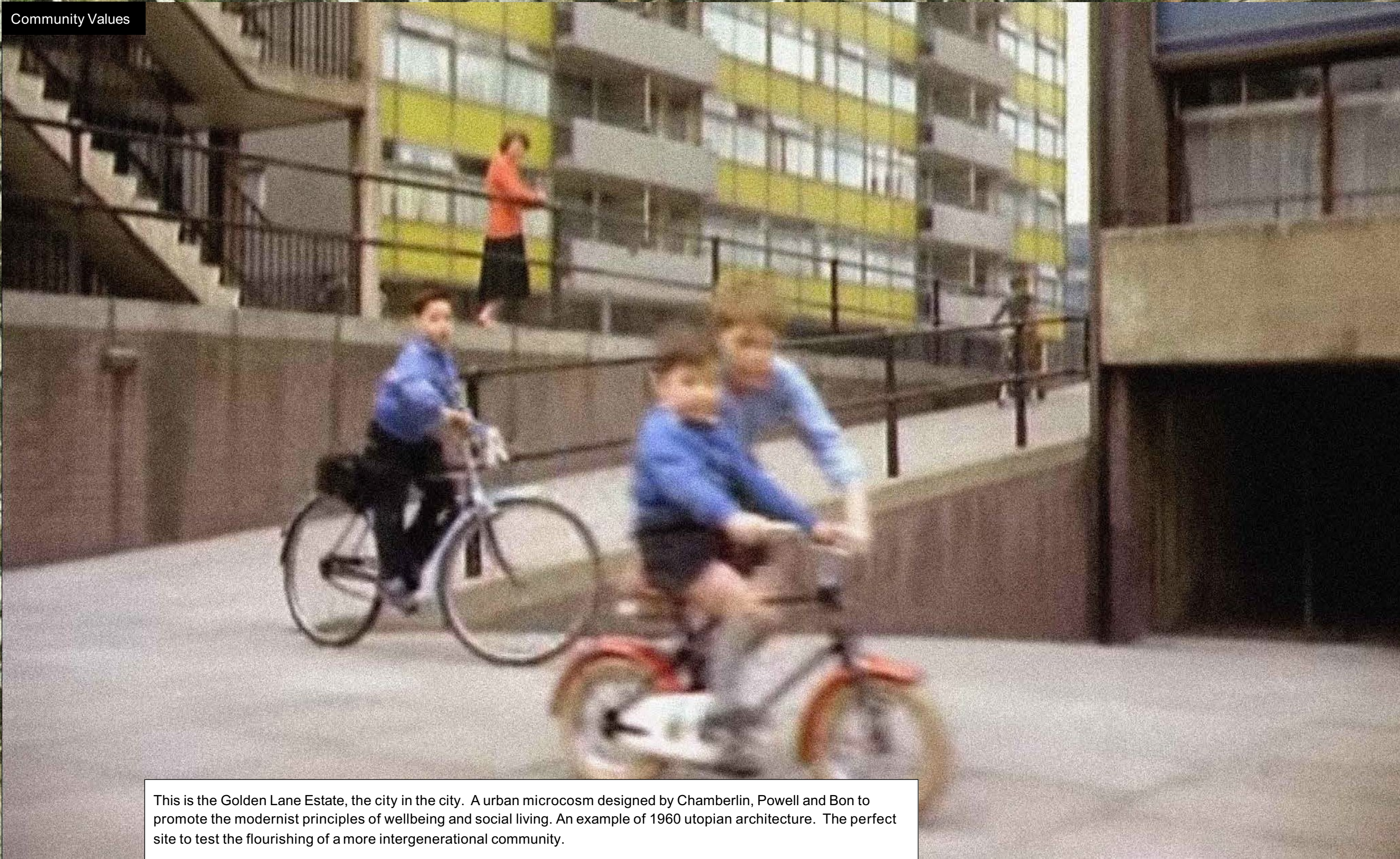

This is the Golden Lane Estate, the city in the city. A urban microcosm designed by Chamberlin, Powell and Bon to promote the modernist principles of wellbeing and social living. An example of 1960 utopian architecture. The perfect site to test the flourishing of a more intergenerational community.



Community Values



This is the Golden Lane Estate, the city in the city. A urban microcosm designed by Chamberlin, Powell and Bon to promote the modernist principles of wellbeing and social living. An example of 1960 utopian architecture. The perfect site to test the flourishing of a more intergenerational community.

Large Public Spaces

Community Values



This is the Golden Lane Estate, the city in the city. A urban microcosm designed by Chamberlin, Powell and Bon to promote the modernist principles of wellbeing and social living. An example of 1960 utopian architecture. The perfect site to test the flourishing of a more intergenerational community.



Wellness Center

Large Public Spaces

Community Values



Community Center



This is the Golden Lane Estate, the city in the city. A urban microcosm designed by Chamberlin, Powell and Bon to promote the modernist principles of wellbeing and social living. An example of 1960 utopian architecture. The perfect site to test the flourishing of a more intergenerational community.

Wellness Center

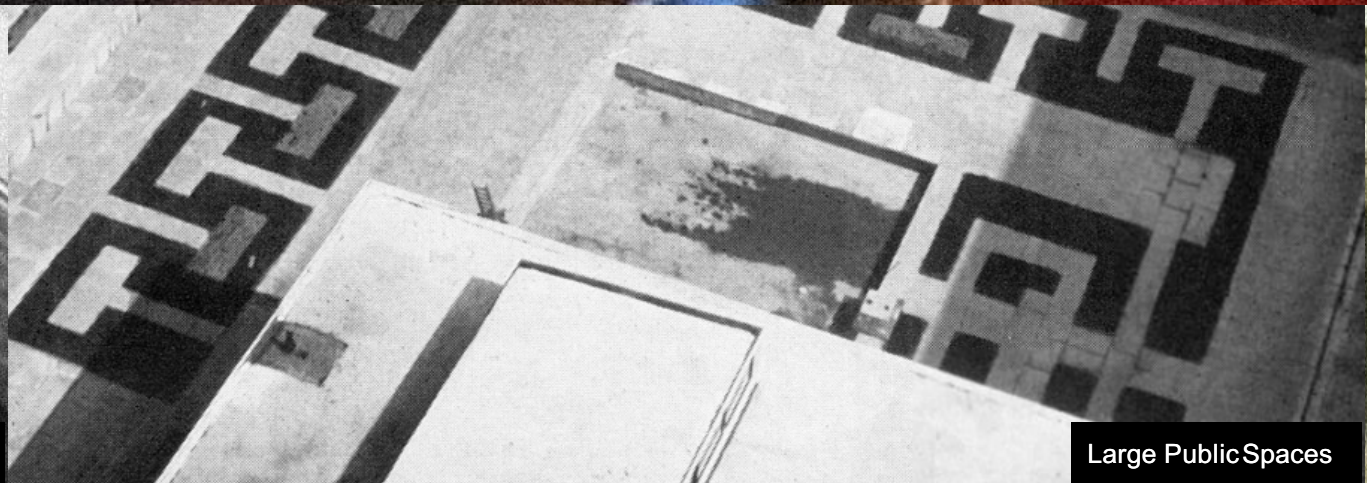

Large Public Spaces

Community Values

Rooftop Terraces

Community Center

This is the Golden Lane Estate, the city in the city. A urban microcosm designed by Chamberlin, Powell and Bon to promote the modernist principles of wellbeing and social living. An example of 1960 utopian architecture. The perfect site to test the flourishing of a more intergenerational community.

Wellness Center

Large Public Spaces



Community Values



Rooftop Terraces



Community Center



Timeless Interiors



This is the Golden Lane Estate, the city in the city. A urban microcosm designed by Chamberlin, Powell and Bon to promote the modernist principles of wellbeing and social living. An example of 1960 utopian architecture. The perfect site to test the flourishing of a more intergenerational community.

Wellness Center

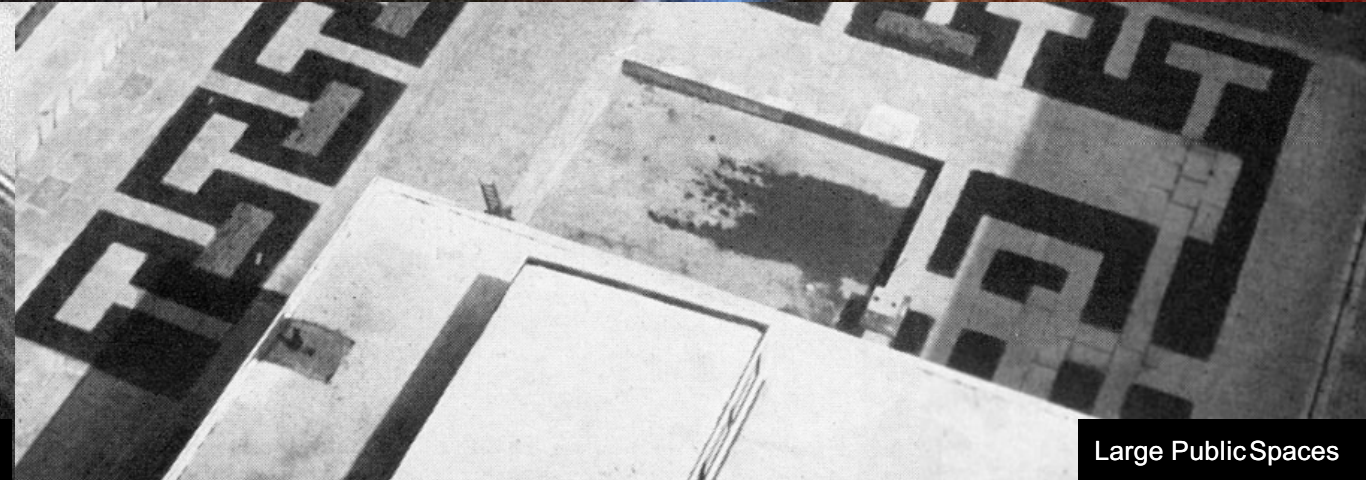

Large Public Spaces





Community Values



Rooftop Terraces



Timeless Interiors



Community Center



Timeless Interiors

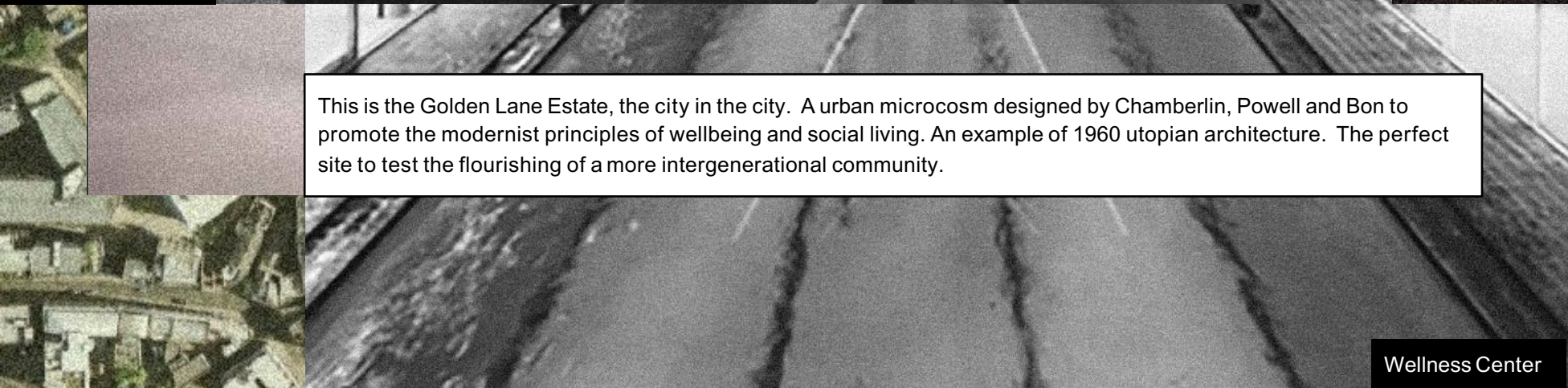

This is the Golden Lane Estate, the city in the city. A urban microcosm designed by Chamberlin, Powell and Bon to promote the modernist principles of wellbeing and social living. An example of 1960 utopian architecture. The perfect site to test the flourishing of a more intergenerational community.

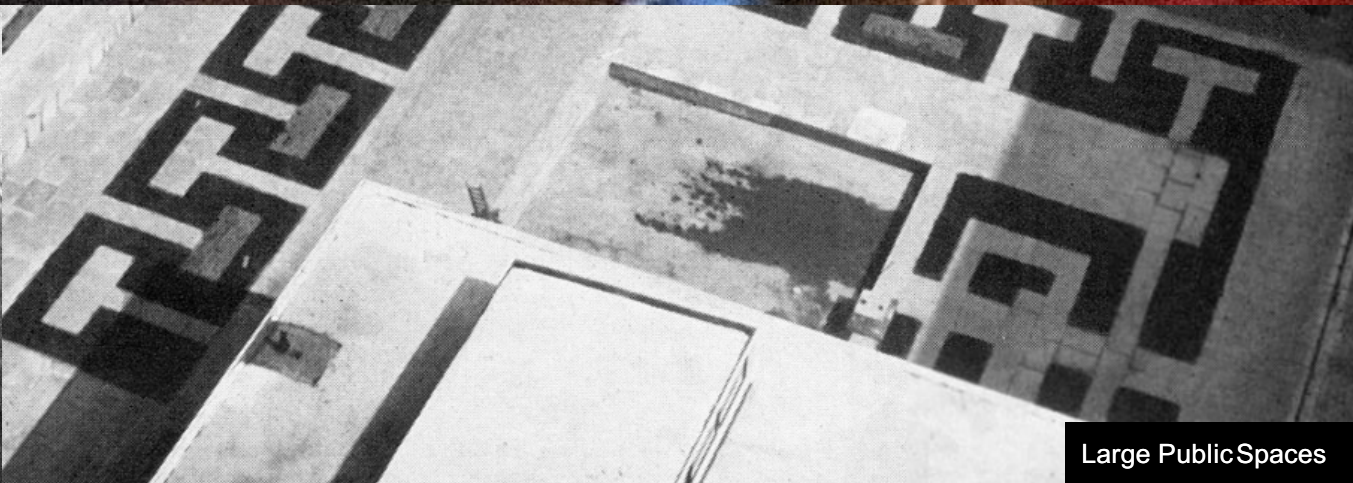

Wellness Center

Large Public Spaces

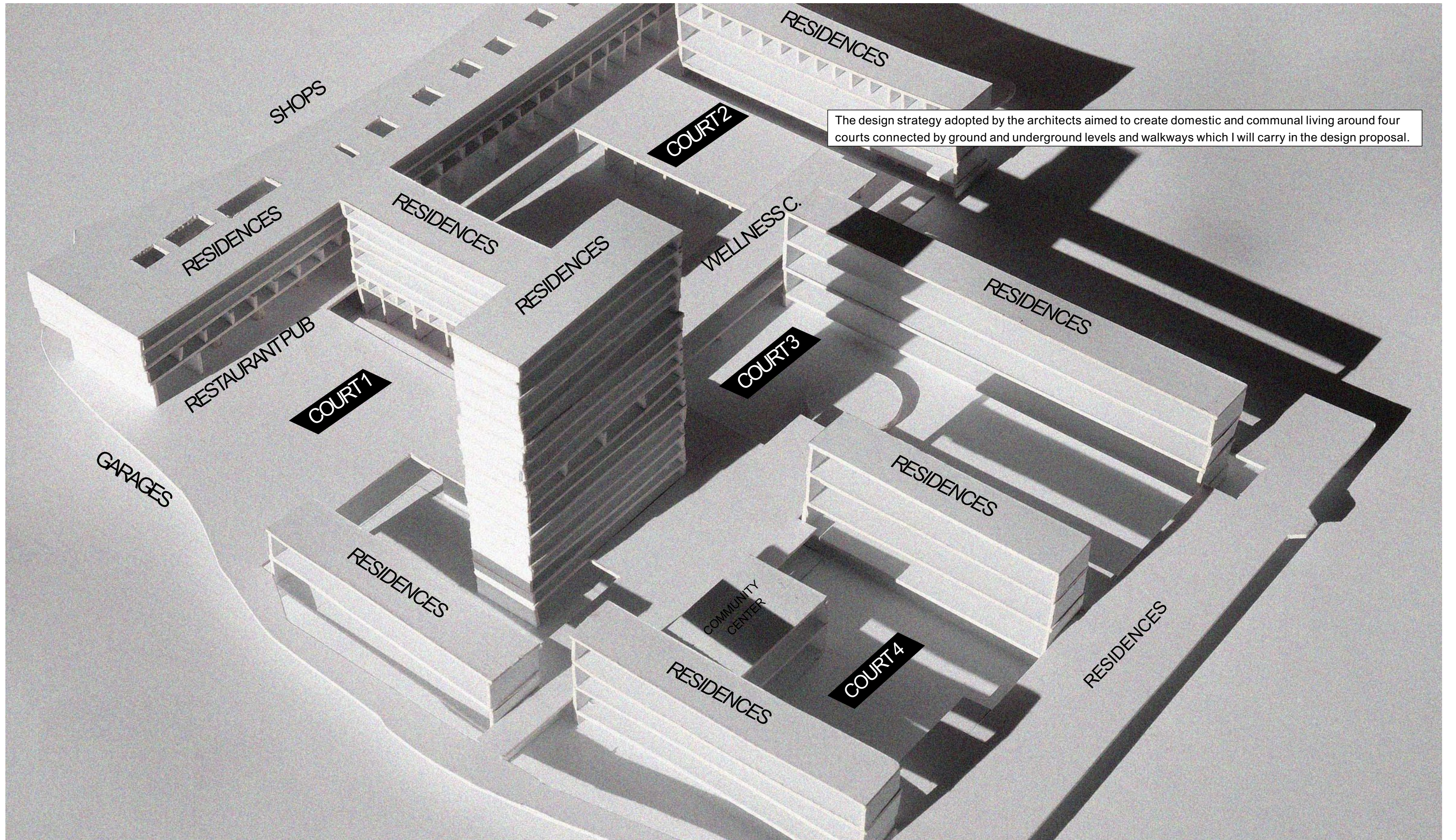

The design strategy adopted by the architects aimed to create domestic and communal living around four courts connected by ground and underground levels and walkways which I will carry in the design proposal.

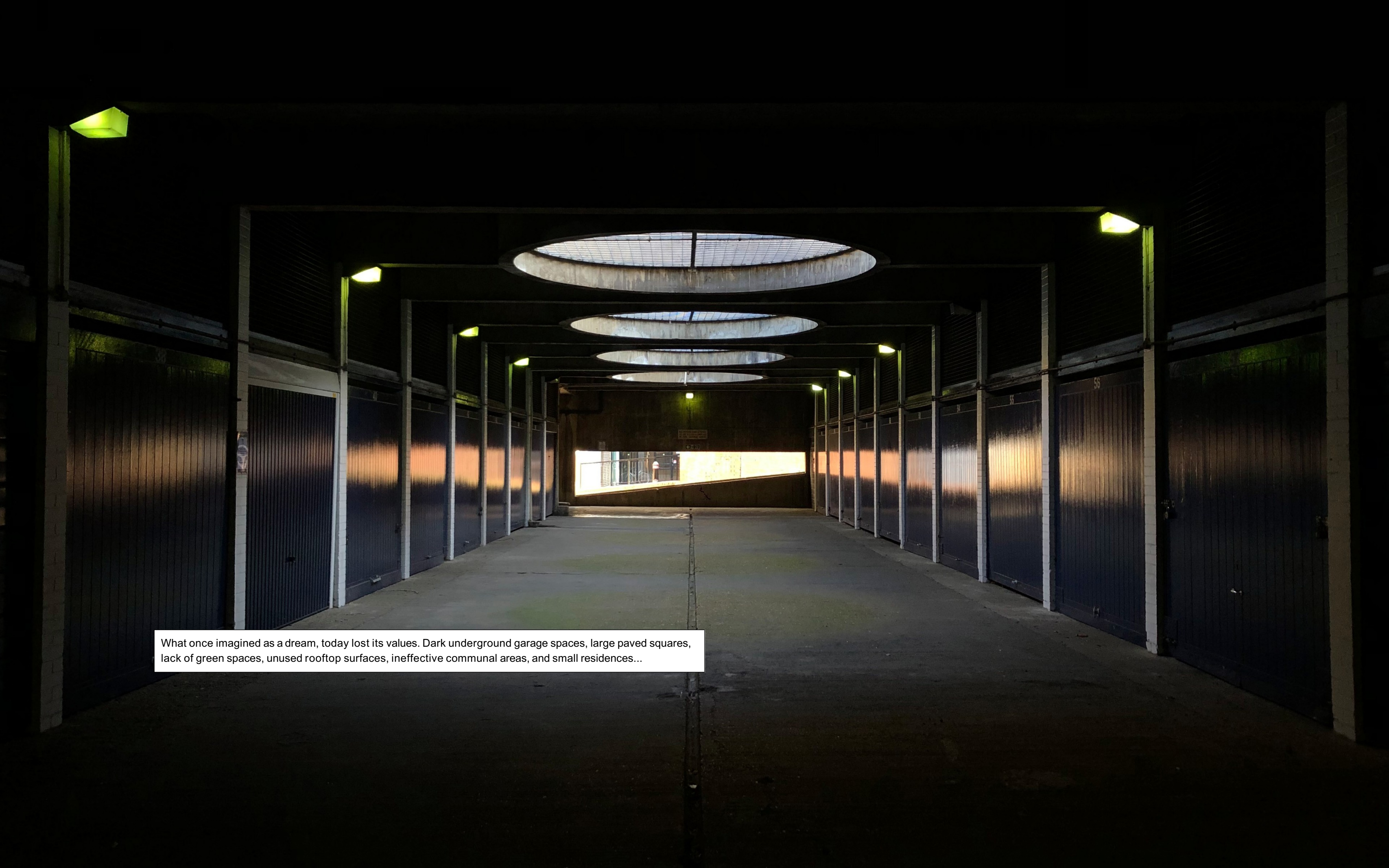

What once imagined as a dream, today lost its values. Dark underground garage spaces, large paved squares, lack of green spaces, unused rooftop surfaces, ineffective communal areas, and small residences...



What once imagined as a dream, today lost its values. Dark underground garage spaces, large paved squares, lack of green spaces, unused rooftop surfaces, ineffective communal areas, and small residences...

Paved Squares



What once imagined as a dream, today lost its values. Dark underground garage spaces, large paved squares, lack of green spaces, unused rooftop surfaces, ineffective communal areas, and small residences...

Underground Spaces



Paved Squares



Paved Squares

What once imagined as a dream, today lost its values. Dark underground garage spaces, large paved squares, lack of green spaces, unused rooftop surfaces, ineffective communal areas, and small residences...

Paved Squares

Paved Squares



What once imagined as a dream, today lost its values. Dark underground garage spaces, large paved squares, lack of green spaces, unused rooftop surfaces, ineffective communal areas, and small residences...

Paved Squares

Paved Squares

Paved Squares

Forgotten high-street Shops

What once imagined as a dream, today lost its values. Dark underground garage spaces, large paved squares, lack of green spaces, unused rooftop surfaces, ineffective communal areas, and small residences...

Paved Squares

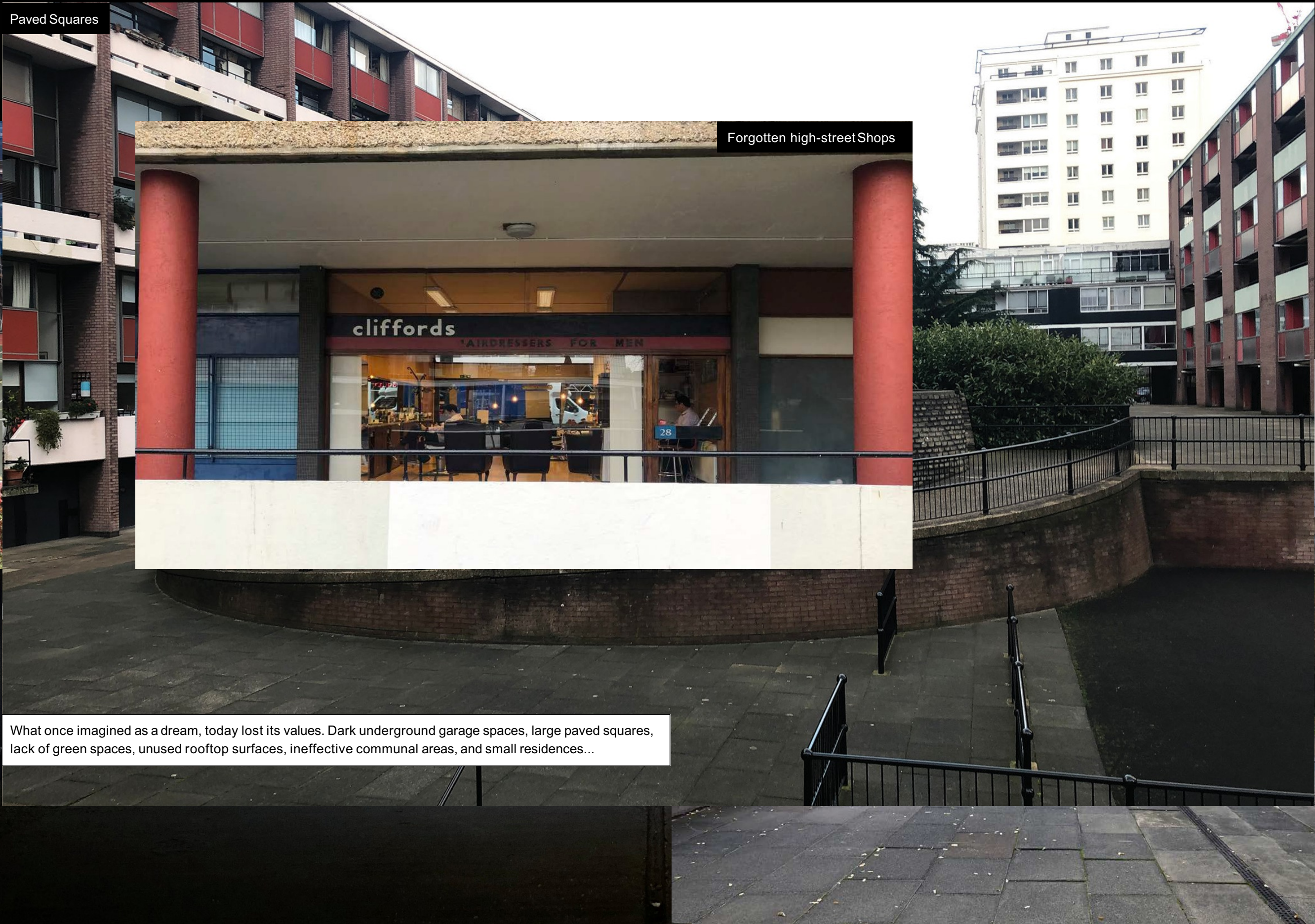

Paved Squares

Paved Squares

Forgotten high-street Shops



1Bedrooms Residences

What once imagined as a dream, today lost its values. Dark underground garage spaces, large paved squares, lack of green spaces, unused rooftop surfaces, ineffective communal areas, and small residences...



Paved Squares

Paved Squares

Paved Squares

Forgotten high-street Shops

2, 3 Bedrooms Residences

1Bedrooms Residences

What once imagined as a dream, today lost its values. Dark underground garage spaces, large paved squares, lack of green spaces, unused rooftop surfaces, ineffective communal areas, and small residences...

Paved Squares

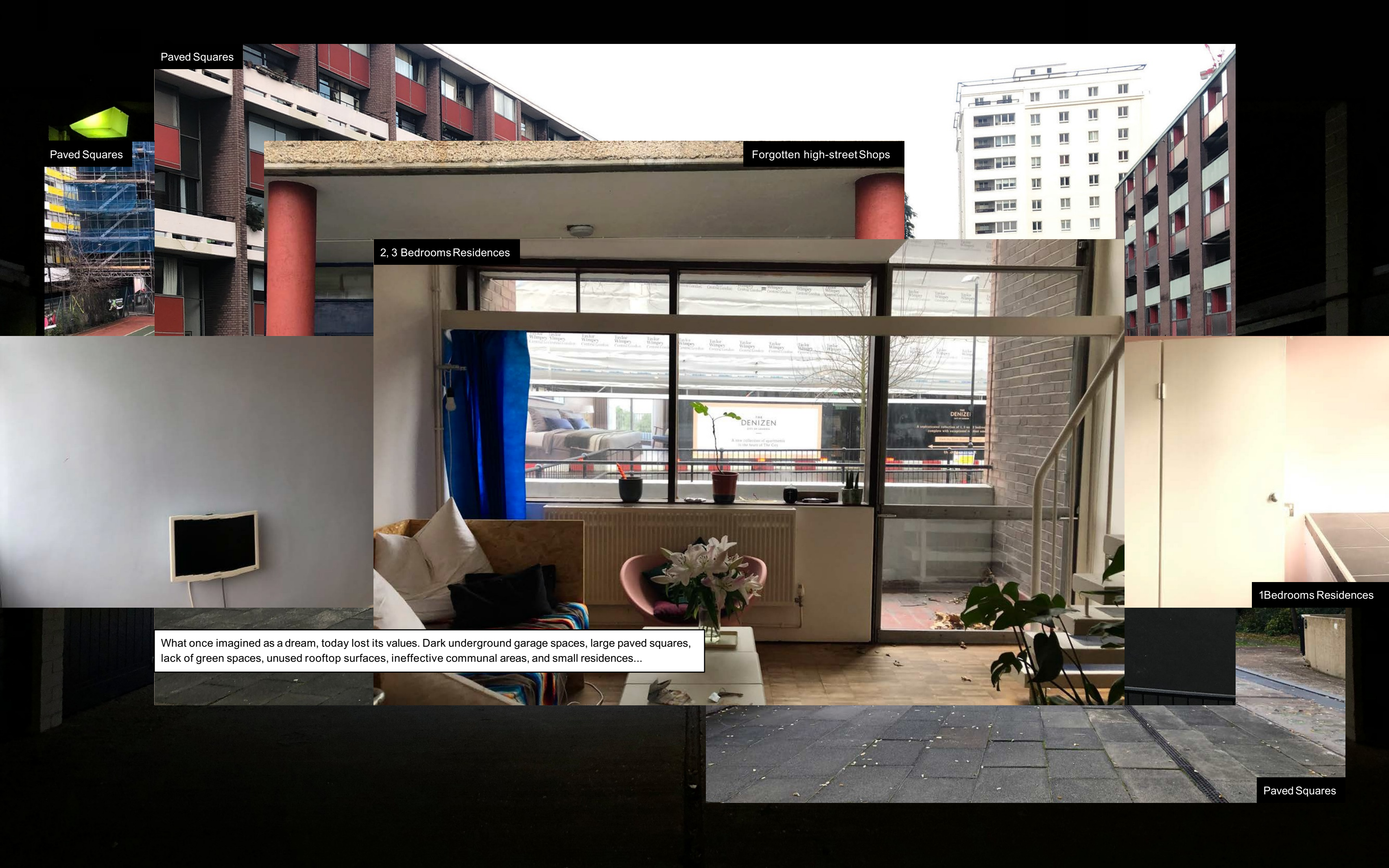

Paved Squares

Paved Squares

Forgotten high-street Shops

2, 3 Bedrooms Residences

1Bedrooms Residences

What once imagined as a dream, today lost its values. Dark underground garage spaces, large paved squares, lack of green spaces, unused rooftop surfaces, ineffective communal areas, and small residences...

Unused Rooftops

Paved Squares





Paved Squares

Paved Squares

Forgotten high-street Shops

2, 3 Bedrooms Residences

1 Bedrooms Residences

What once imagined as a dream, today lost its values. Dark underground garage spaces, large paved squares, lack of green spaces, unused rooftop surfaces, ineffective communal areas, and small residences...

Unused Rooftops

Unused Rooftops

Paved Squares

# DEAR GOLDEN LANE ESTATE, I AM LOOKING FOR YOUR HELP.

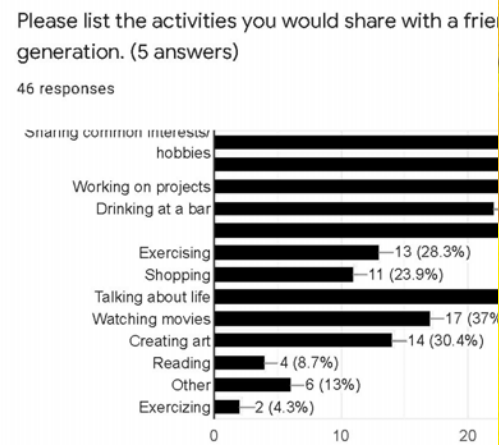
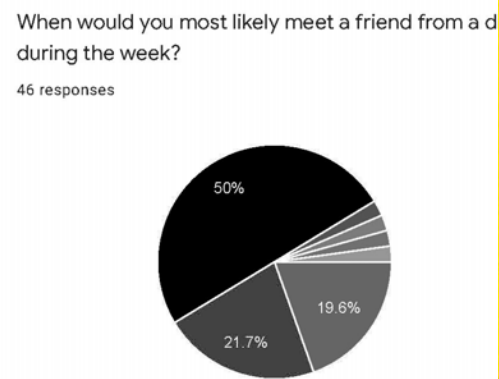
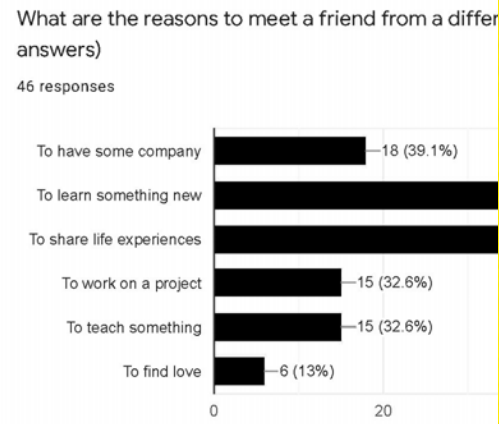

Where would you most likely meet friends from a different generation? (5 answers)

46 responses

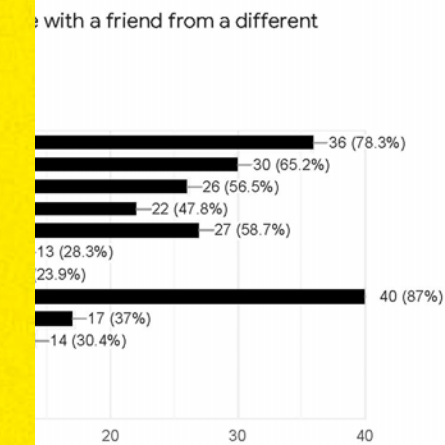
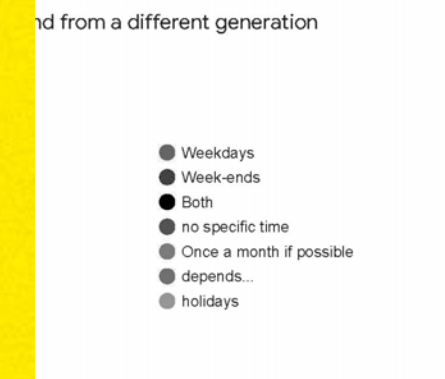
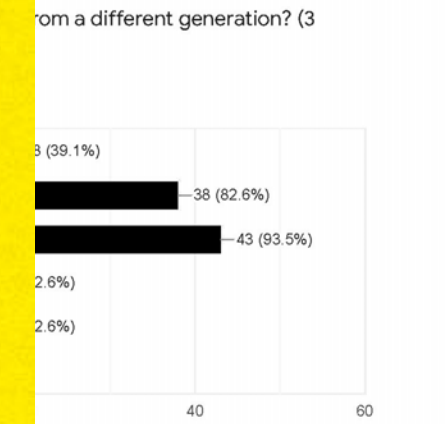

Where would you most likely meet friends from a different generation? (5 answers)

46 responses

I am Adalberto Lonardi, a master student in architecture at the Royal College of Art, and I am looking at how to create multigenerational spaces in a community.

I interviewed the residents of the Estate and asked what they were missing and dreaming for a better community and if they would be interested in reconnecting with different generations.

I am looking for 1 younger resident (+20) and 1 older resident (+70) to have a chat over a cup



The residents reclaimed greener spaces, pets allowed, a coordinated program of activities complained about the degradation of the public areas, and dreamed about shared workshops, farmland, a radio station.



The residents reclaimed greener spaces, pets allowed, a coordinated program of activities complained about the degradation of the public areas, and dreamed about shared workshops, farmland, a radio station.



The residents reclaimed greener spaces, pets allowed, a coordinated program of activities complained about the degradation of the public areas, and dreamed about shared workshops, farmland, a radio station.



The residents reclaimed greener spaces, pets allowed, a coordinated program of activities complained about the degradation of the public areas, and dreamed about shared workshops, farmland, a radio station.



The residents reclaimed greener spaces, pets allowed, a coordinated program of activities complained about the degradation of the public areas, and dreamed about shared workshops, farmland, a radio station.



The residents reclaimed greener spaces, pets allowed, a coordinated program of activities complained about the degradation of the public areas, and dreamed about shared workshops, farmland, a radio station.

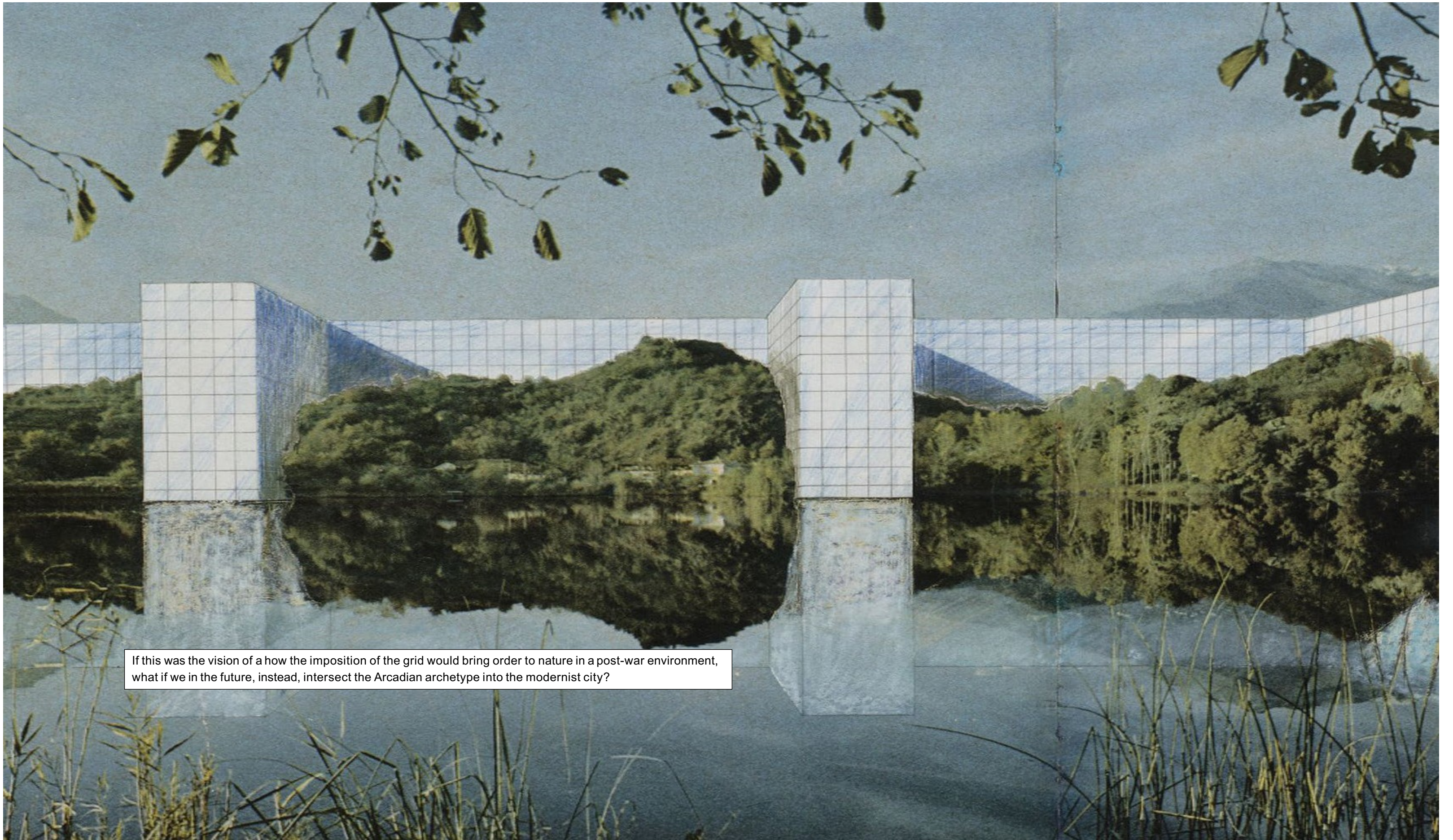

If this was the vision of a how the imposition of the grid would bring order to nature in a post-war environment, what if we in the future, instead, intersect the Arcadian archetype into the modernist city?

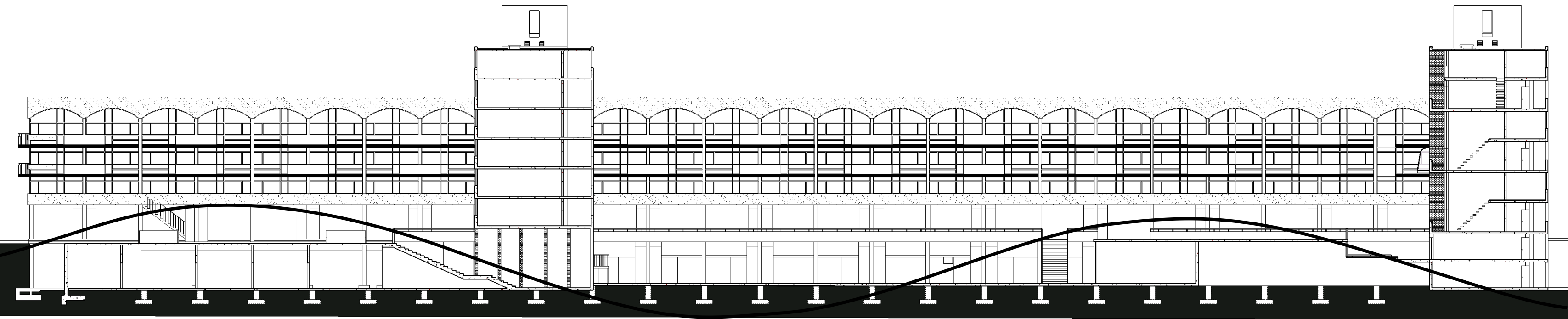

In a near future, when we, humans, finally learned that together we are stronger, nature is sacred, technology is our alliance, and life is slow...

### Grow your own: Urban farming is flourishing during the coronavirus lockdowns



**World Economic Forum**  
February 23 · See More

Lockdown has made us re-evaluate the importance of public spaces. ... See More

**YOUR VICTORY GARDEN counts more than ever!**

WEFORUM.ORG

**Urban farming is flourishing during the coronavirus lockdowns**

The coronavirus lockdowns are making city dwellers realise how cr...



Copenhagen is planting fruit trees in the street for everyone to enjoy

### Green Spaces/Farming Conversions

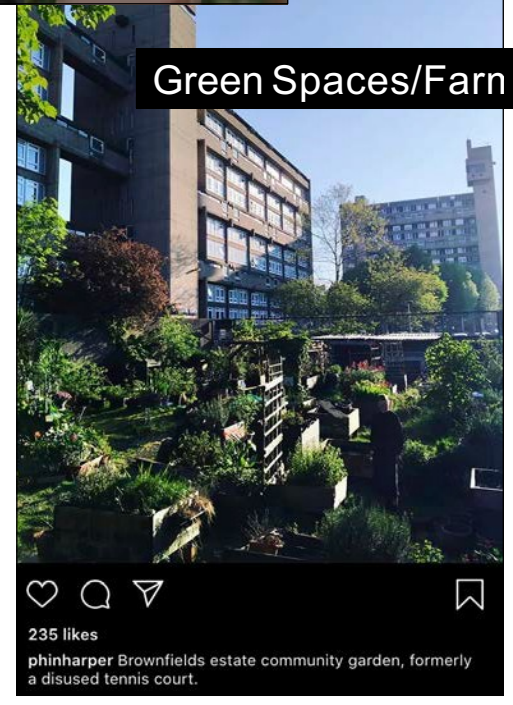

235 likes  
phinharper Brownfields estate community garden, formerly a disused tennis court.



**BBC NEWS**  
BBC.COM  
**The three grandmothers self-isolating together**  
Doreen, Carol and Dotty have come up with a plan to...

### Co-living Species

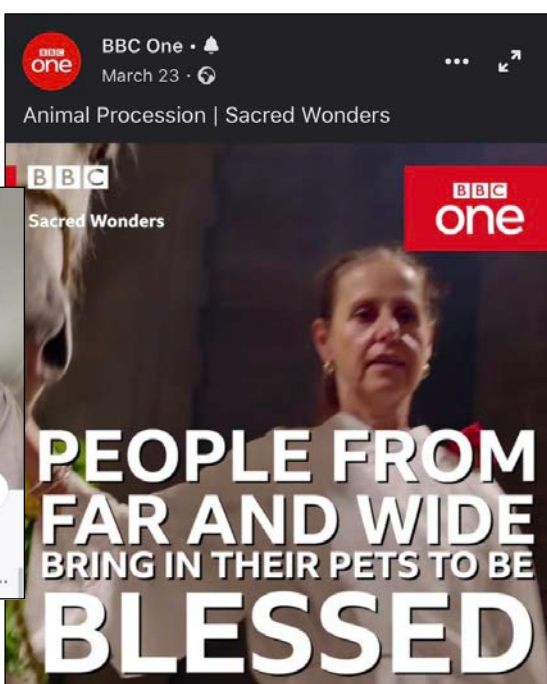

### PEOPLE FROM FAR AND WIDE BRING IN THEIR PETS TO BE BLESSED

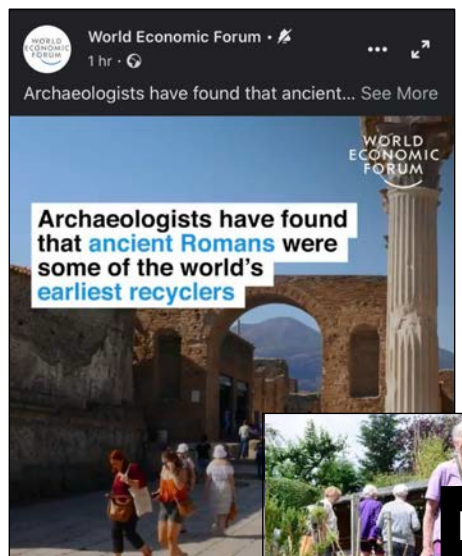

**World Economic Forum**  
1 hr · See More

Archaeologists have found that ancient Romans were some of the world's earliest recyclers

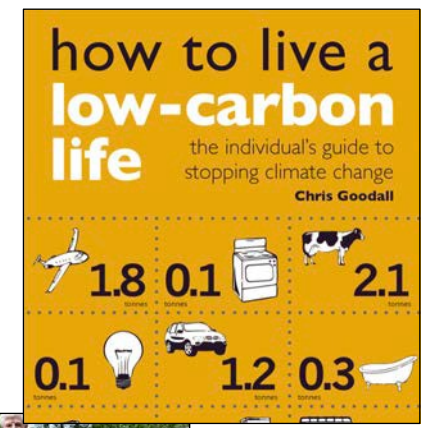

### Low Carbon Lifestyle



**UK news**  
**Could you live a low carbon life? Meet the people who already are**

There are things we can all do to lower our impact on the environment. We speak to three people who have taken the first steps



**Smart homes**  
**'Hey Google, dim the smart home device money**

Smart Living

From energy-saving bulbs to leak detectors, smart tech offers many benefits at the touch of a button

1 week ago



**BBC NEWS**  
**Tomorrow's Cities: Will the bike become an urban must-have?**  
By Jane Wakefield  
Technology reporter

### Automated/Human Powered Vehicles



**de zeen**  
Toyota announces e-Pale...  
**Toyota reveals vision for driverless vehicles that switch function on demand**

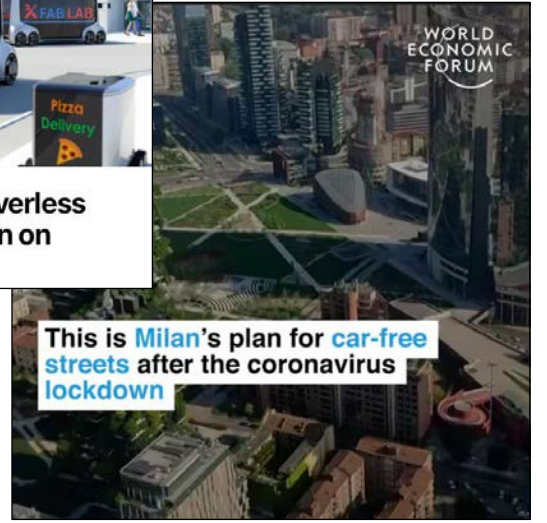

**World Economic Forum**  
This is Milan's plan for car-free streets after the coronavirus lockdown

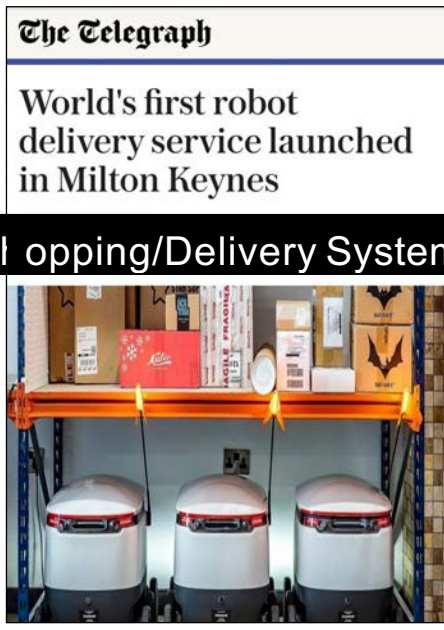

**The Telegraph**  
**World's first robot delivery service launched in Milton Keynes**

### Automated Shopping/Delivery System

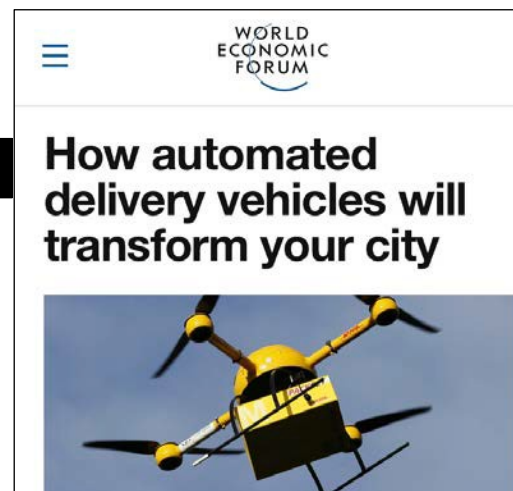

**World Economic Forum**  
**How automated delivery vehicles will transform your city**

...a simple, sustainable and integrated life will begin.

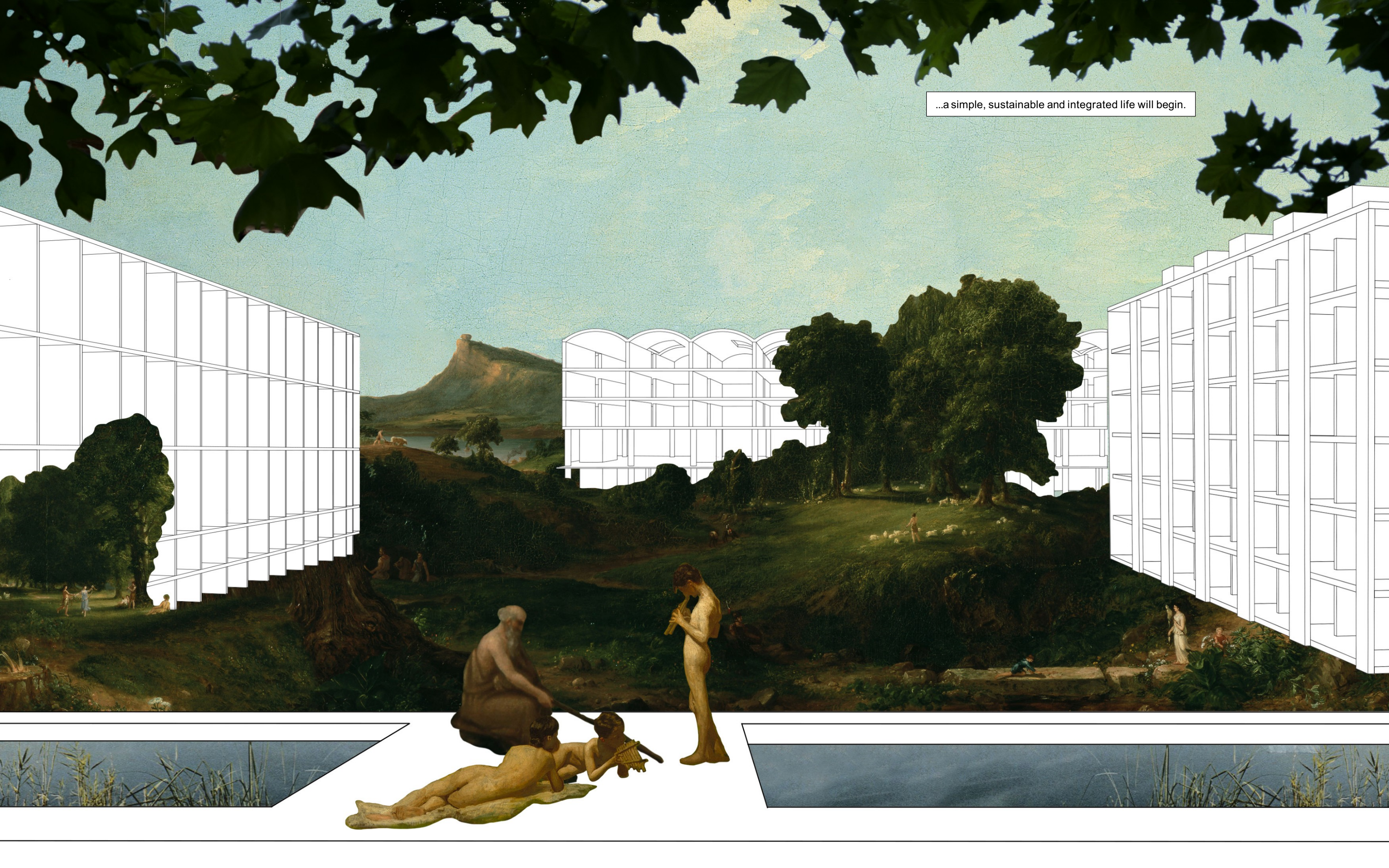

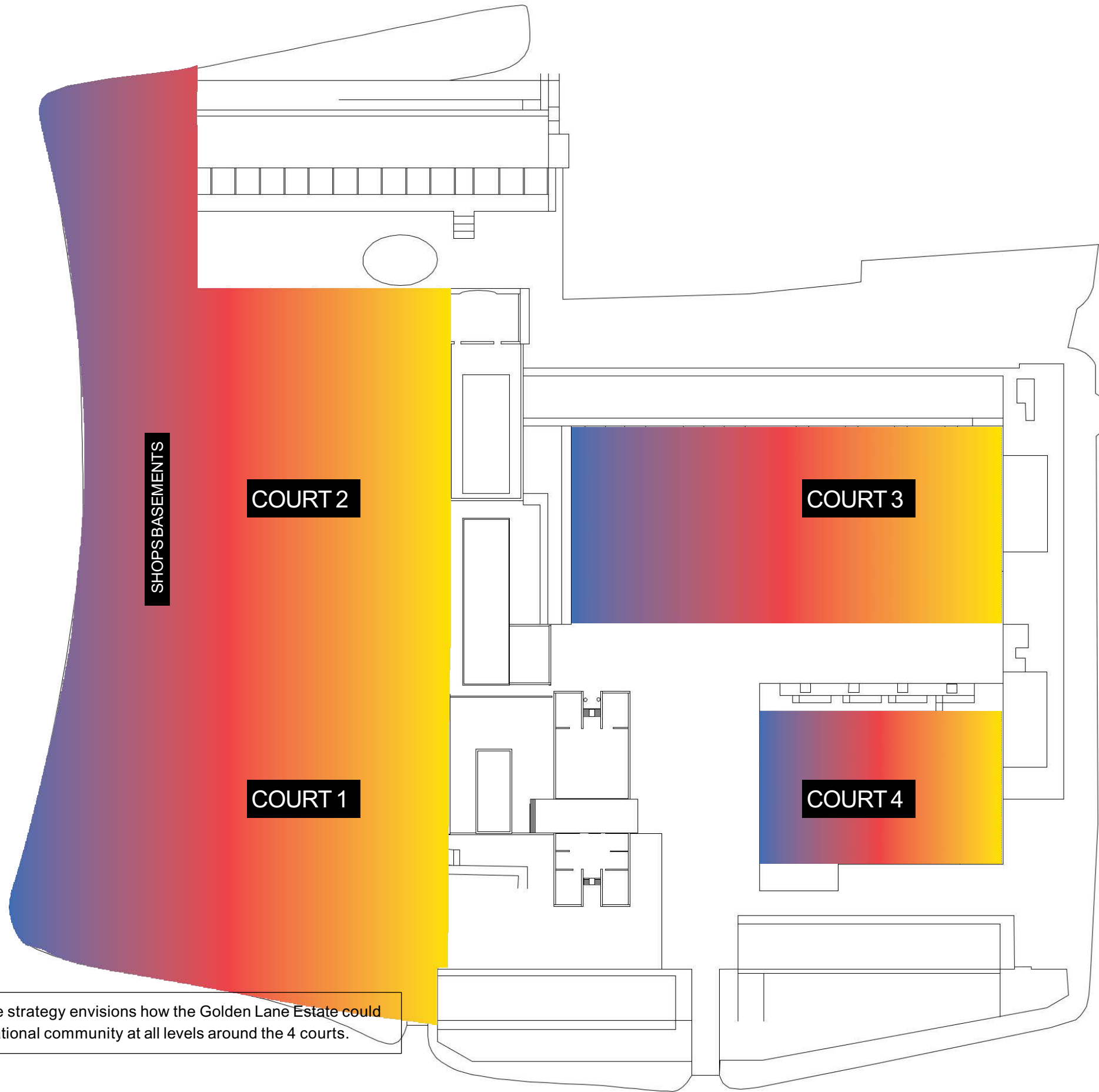

Using findings and site-specific research, a tripartite strategy envisions how the Golden Lane Estate could transform for a growing sustainable and intergenerational community at all levels around the 4 courts.

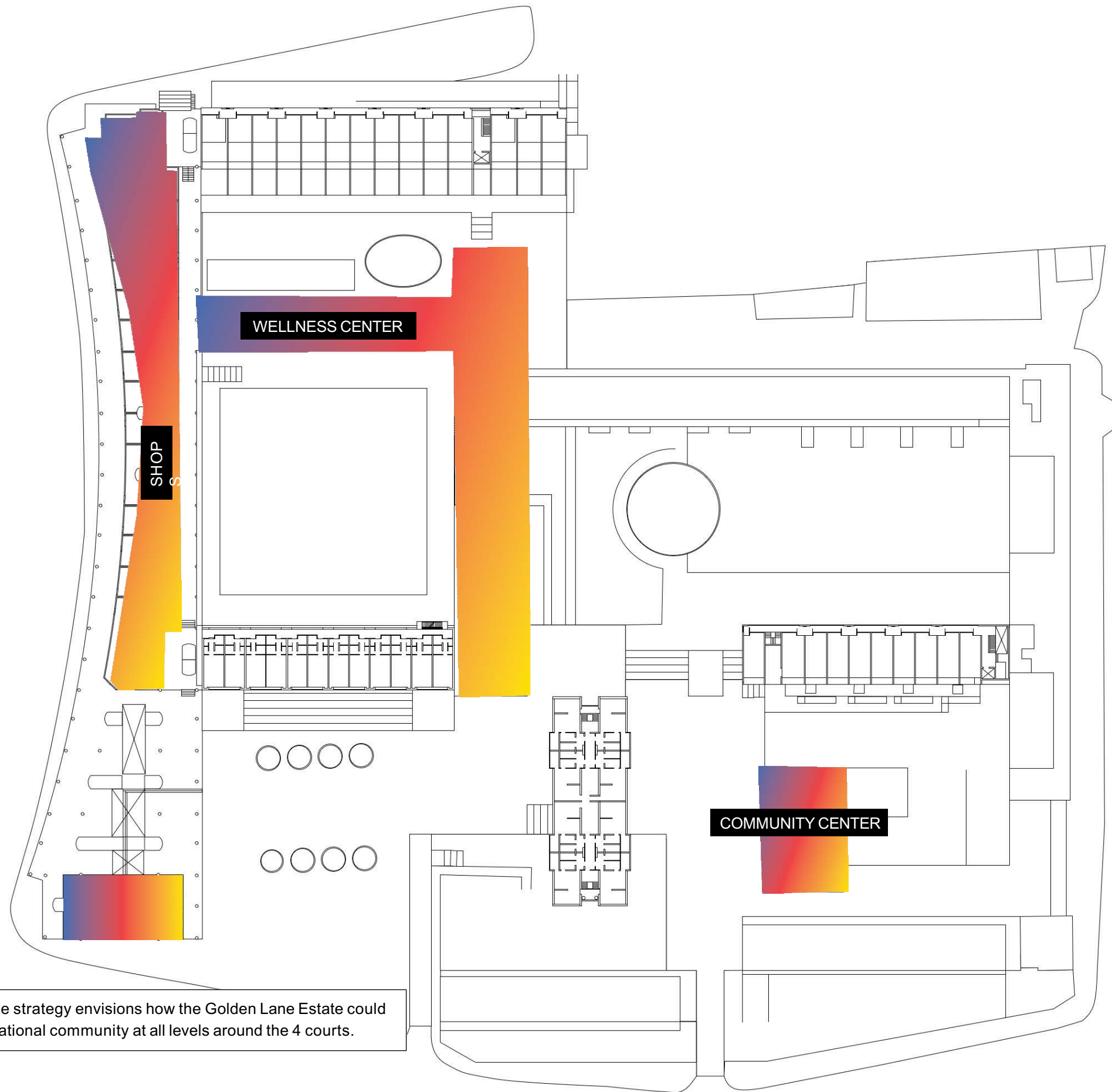

ground level

Using findings and site-specific research, a tripartite strategy envisions how the Golden Lane Estate could transform for a growing sustainable and intergenerational community at all levels around the 4 courts.

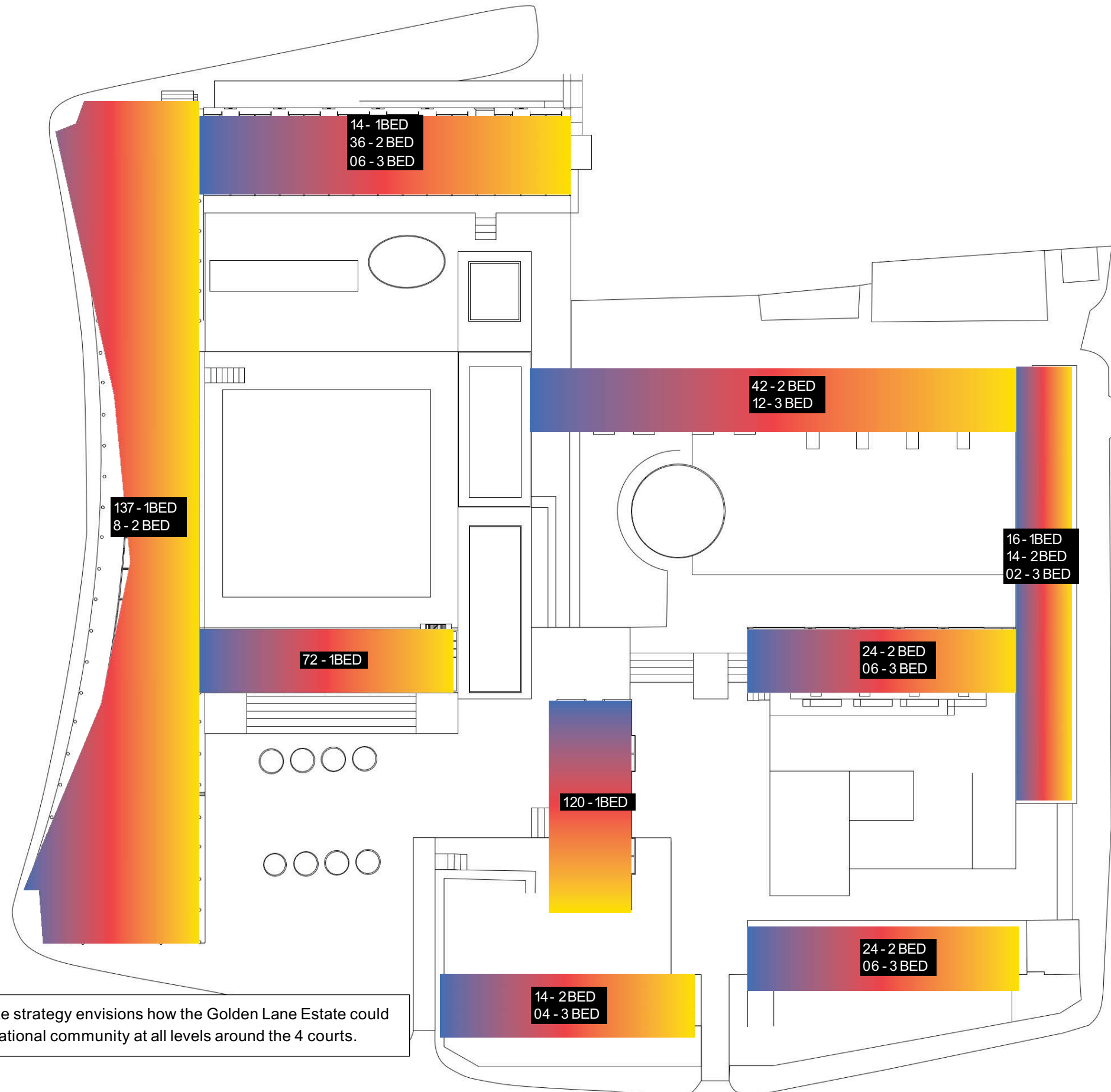

residences

Using findings and site-specific research, a tripartite strategy envisions how the Golden Lane Estate could transform for a growing sustainable and intergenerational community at all levels around the 4 courts.

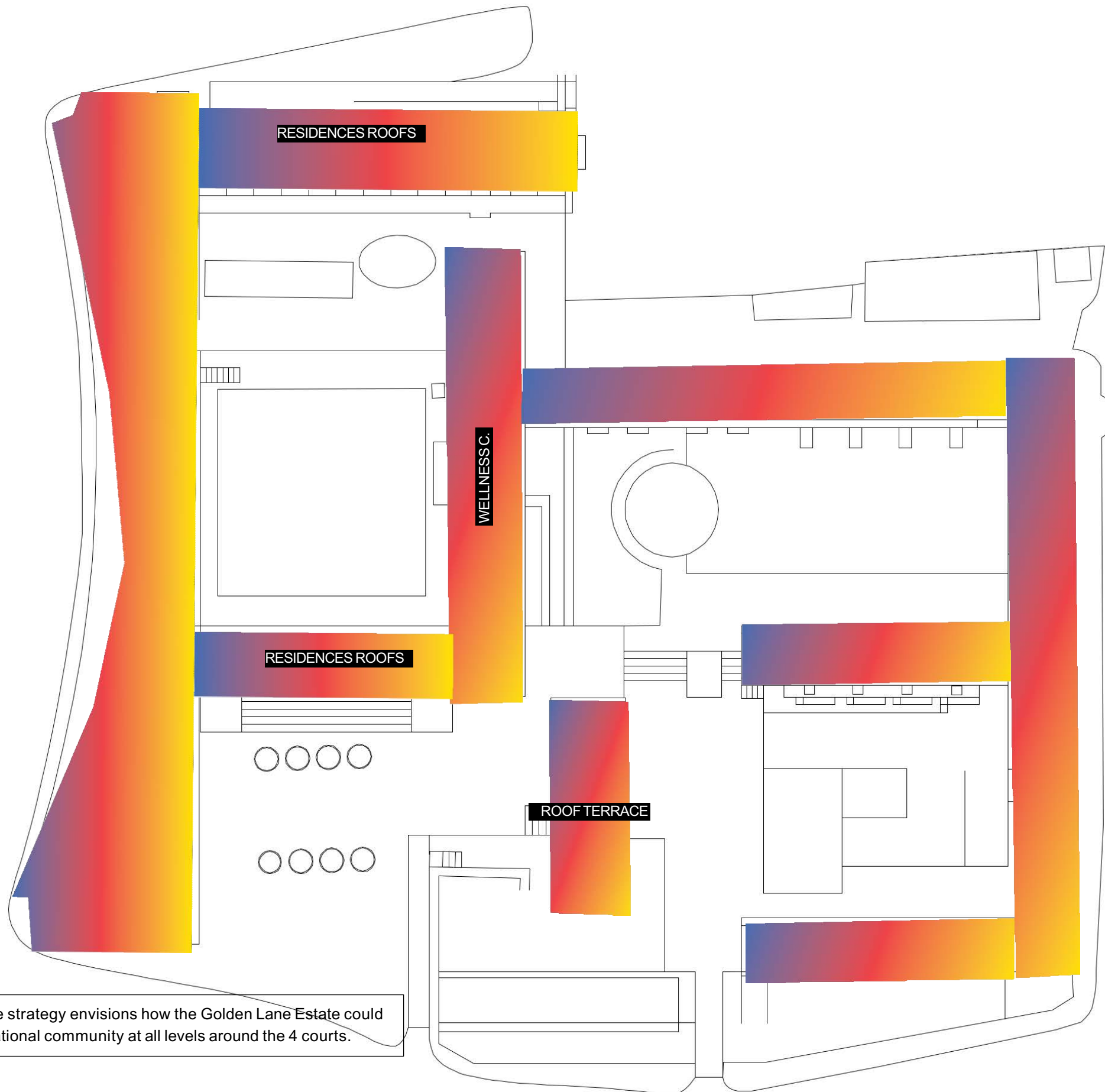

roof toplevels

Using findings and site-specific research, a tripartite strategy envisions how the Golden Lane Estate could transform for a growing sustainable and intergenerational community at all levels around the 4 courts.

The United Generations is a sustainable ecosystem with a domestic and public scheme where the residents and the community are engaged through activities and events that combine social, economic, and cultural values contributing to the wellness and the reconnection of old and new generations.



The Adaptable Domestic Scheme (ADS) allows the residents to stay in the community by adapting/exchange the existing homes when space is needed.

Allows all residents and the public to engaged through intergenerational activities that combinesocial, economic, and cultural values.

The Adaptable Public Scheme (APS) allows all residents to have access to shared facilities that keep them close to what they need on a daily basis.

At the domestic level, the Adaptable Domestic Scheme (ADS) proposes reversible physical home adaptations of scale and accessibility that enable residents to stay in the Estate through the phases of life.

DOMESTIC SCHEME TYPOLOGIES RECONFIGURATION

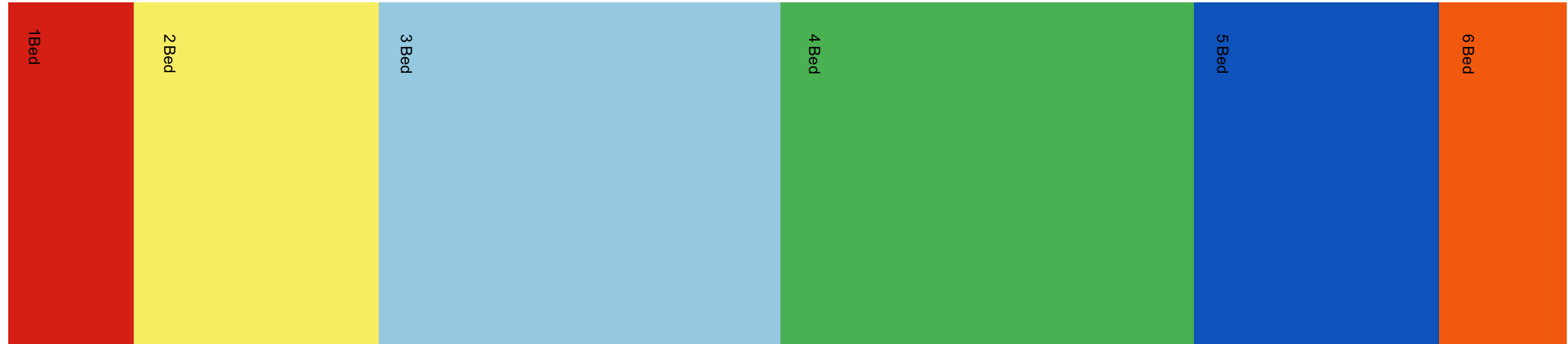

The United Generations



Golden Lane Estate 1962

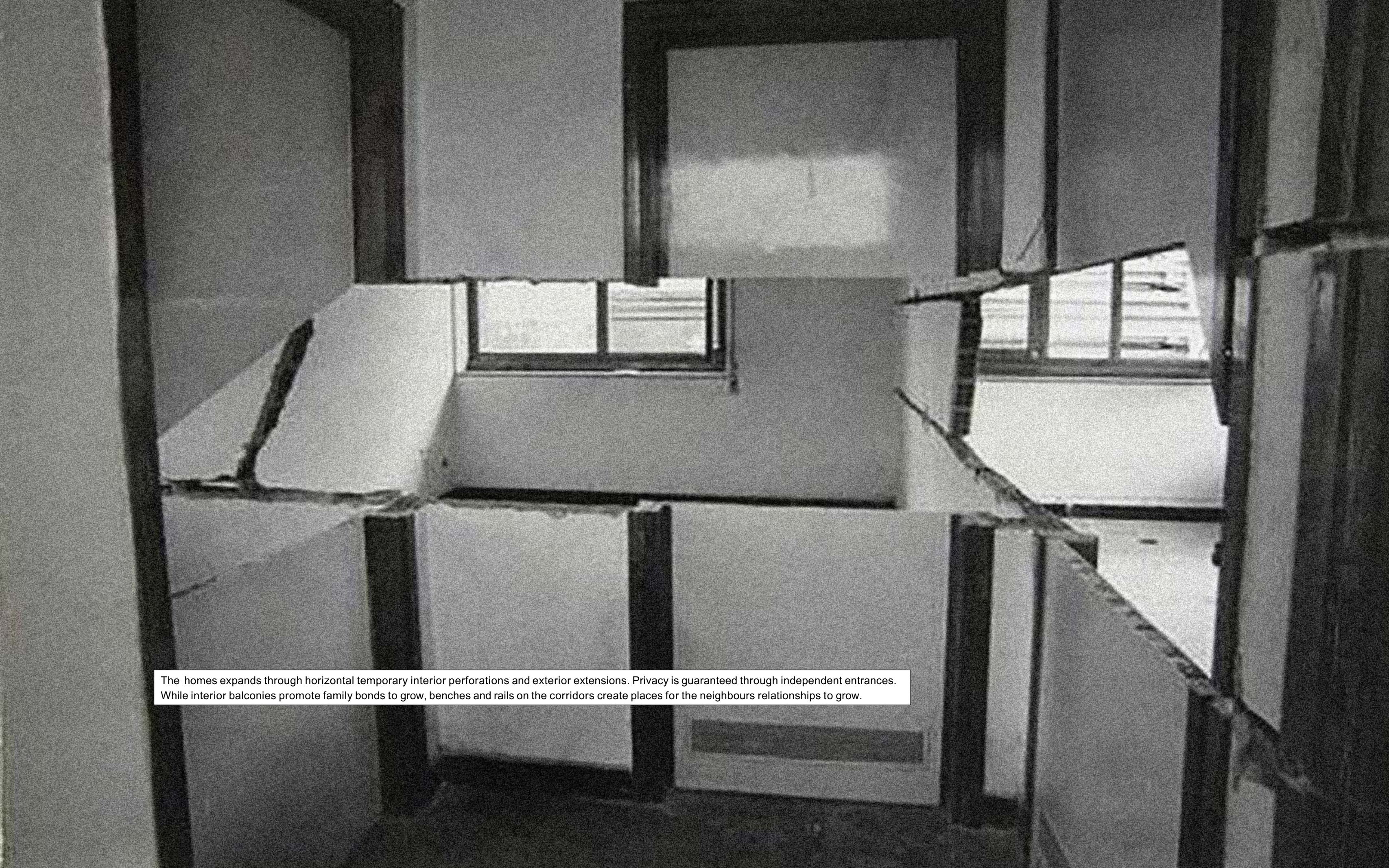

The homes expands through horizontal temporary interior perforations and exterior extensions. Privacy is guaranteed through independent entrances. While interior balconies promote family bonds to grow, benches and rails on the corridors create places for the neighbours relationships to grow.



The homes expands through horizontal temporary interior perforations and exterior extensions. Privacy is guaranteed through independent entrances. While interior balconies promote family bonds to grow, benches and rails on the corridors create places for the neighbours relationships to grow.



The homes expands through horizontal temporary interior perforations and exterior extensions. Privacy is guaranteed through independent entrances. While interior balconies promote family bonds to grow, benches and rails on the corridors create places for the neighbours relationships to grow.

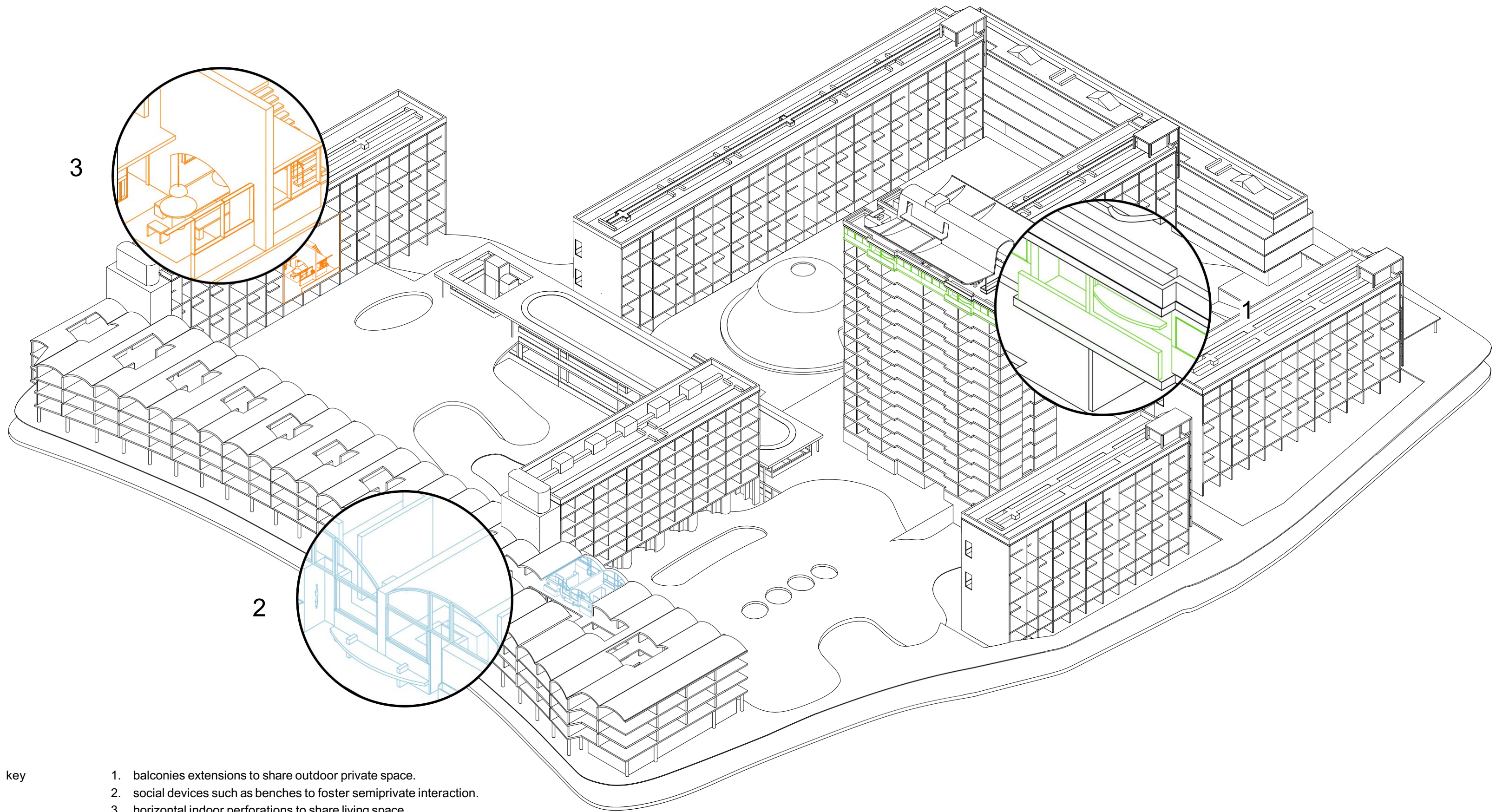

key

1. balconies extensions to share outdoor private space.
2. social devices such as benches to foster semiprivate interaction.
3. horizontal indoor perforations to share living space.

At the Estate level, the Adaptable Public Scheme (APS) merges internal and external spaces hosting activities that promote intergenerational moments connected to nature, care of the body, exercise, work, performance, spirituality, farming and food.

PUBLIC SCHEME PROGRAMS RECONFIGURATION

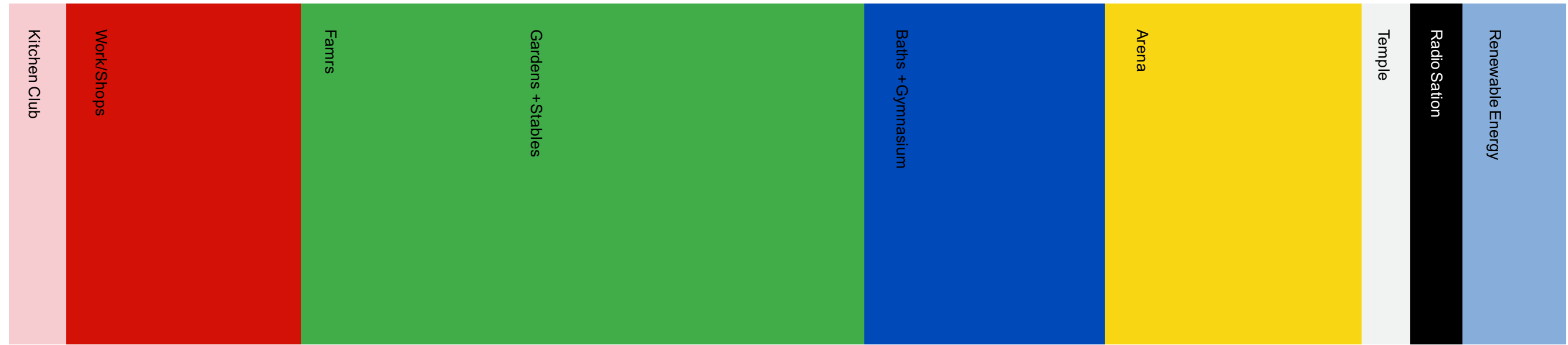

The United Generations



Golden Lane Estate 1962

At the Estate level, the Adaptable Public Scheme (APS) merges internal and external spaces hosting activities that promote intergenerational moments connected to nature, care of the body, exercise, work, performance, spirituality, farming and food.



At the Estate level, the Adaptable Public Scheme (APS) merges internal and external spaces hosting activities that promote intergenerational moments connected to nature, care of the body, exercise, work, performance, spirituality, farming and food.

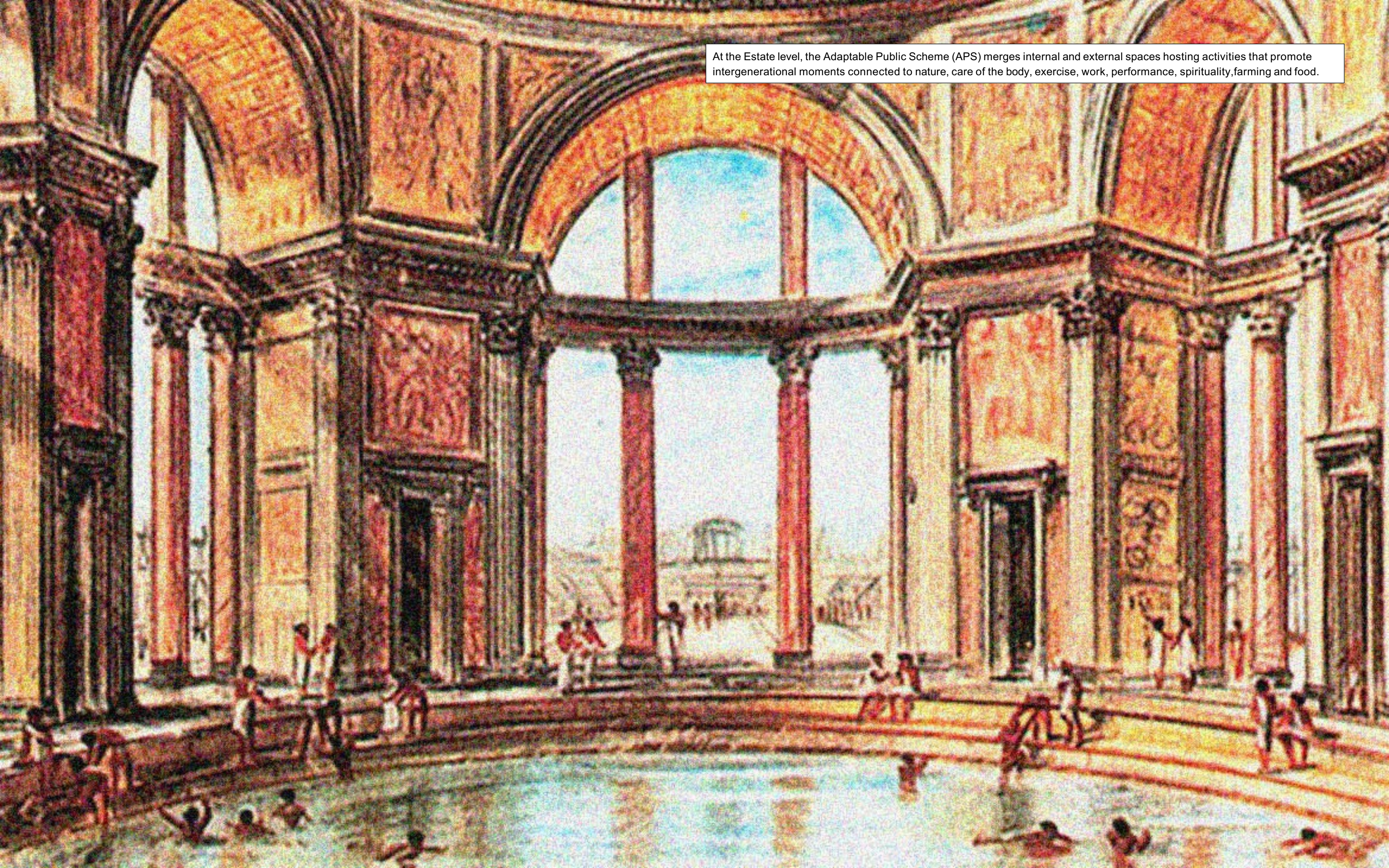

At the Estate level, the Adaptable Public Scheme (APS) merges internal and external spaces hosting activities that promote intergenerational moments connected to nature, care of the body, exercise, work, performance, spirituality, farming and food.

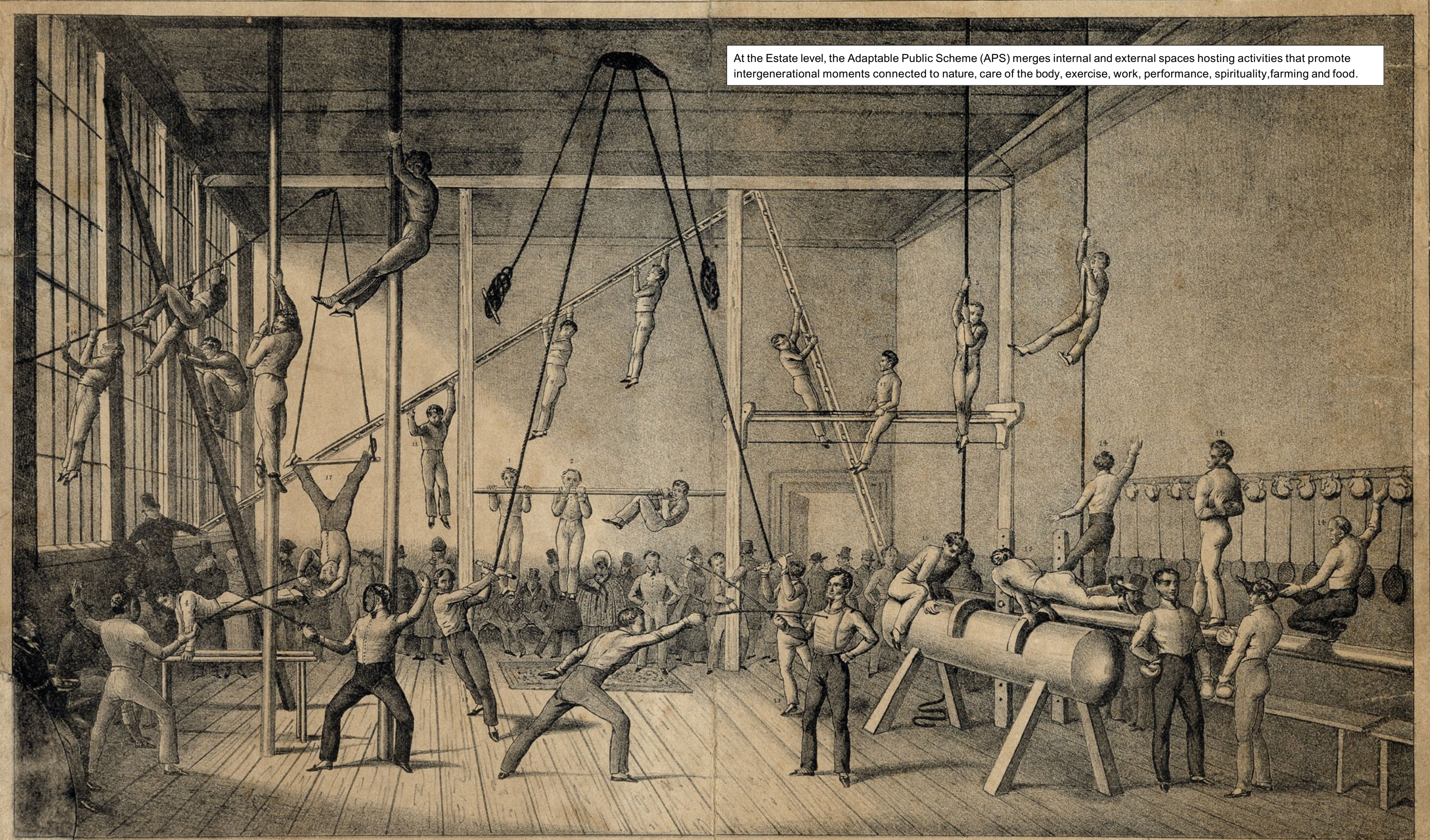

At the Estate level, the Adaptable Public Scheme (APS) merges internal and external spaces hosting activities that promote intergenerational moments connected to nature, care of the body, exercise, work, performance, spirituality, farming and food.



At the Estate level, the Adaptable Public Scheme (APS) merges internal and external spaces hosting activities that promote intergenerational moments connected to nature, care of the body, exercise, work, performance, spirituality, farming and food.

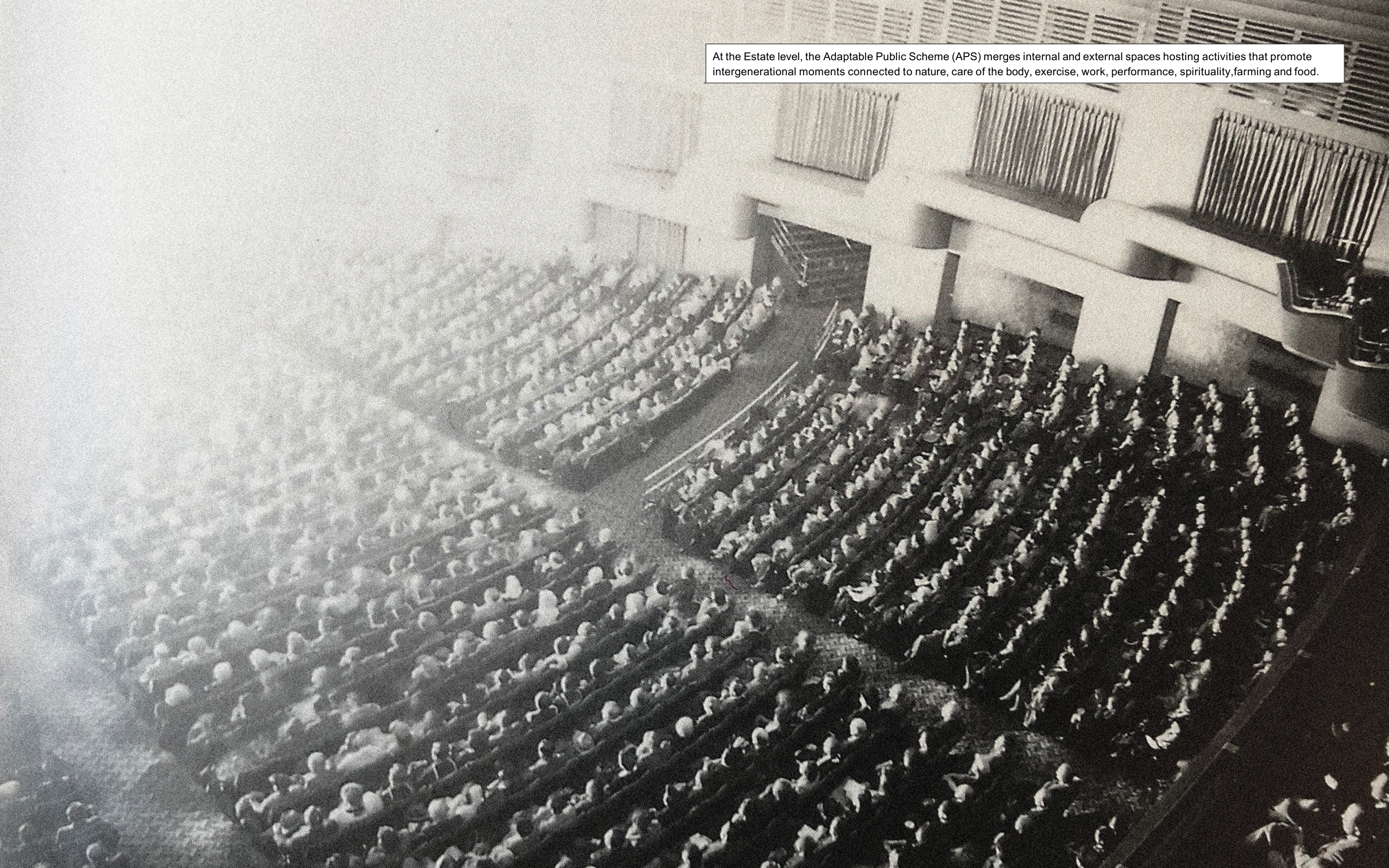

At the Estate level, the Adaptable Public Scheme (APS) merges internal and external spaces hosting activities that promote intergenerational moments connected to nature, care of the body, exercise, work, performance, spirituality, farming and food.



At the Estate level, the Adaptable Public Scheme (APS) merges internal and external spaces hosting activities that promote intergenerational moments connected to nature, care of the body, exercise, work, performance, spirituality, farming and food.



At the Estate level, the Adaptable Public Scheme (APS) merges internal and external spaces hosting activities that promote intergenerational moments connected to nature, care of the body, exercise, work, performance, spirituality, farming and food.



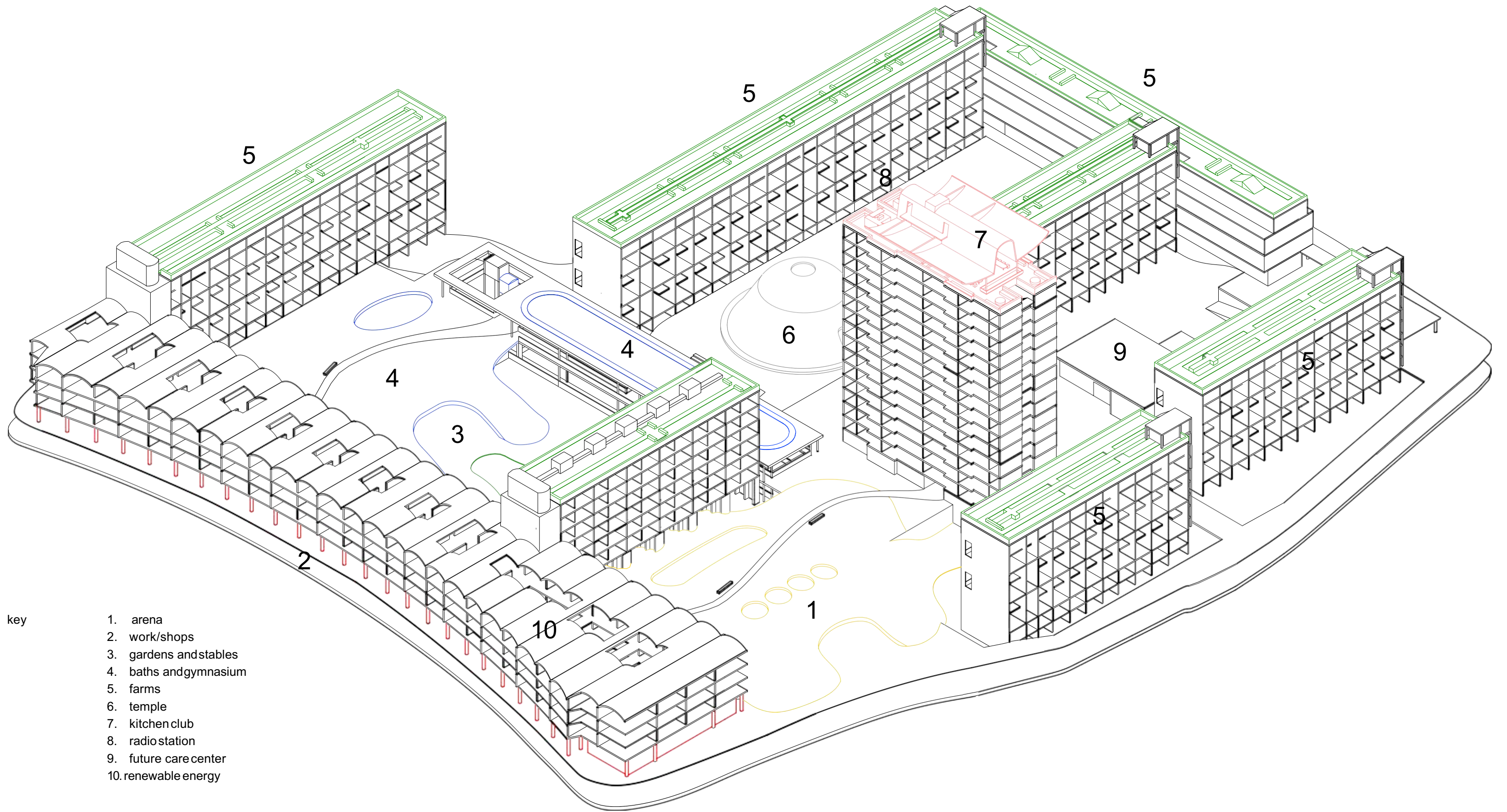

key

- 1. arena
- 2. work/shops
- 3. gardens and stables
- 4. baths and gymnasium
- 5. farms
- 6. temple
- 7. kitchen club
- 8. radio station
- 9. future care center
- 10. renewable energy



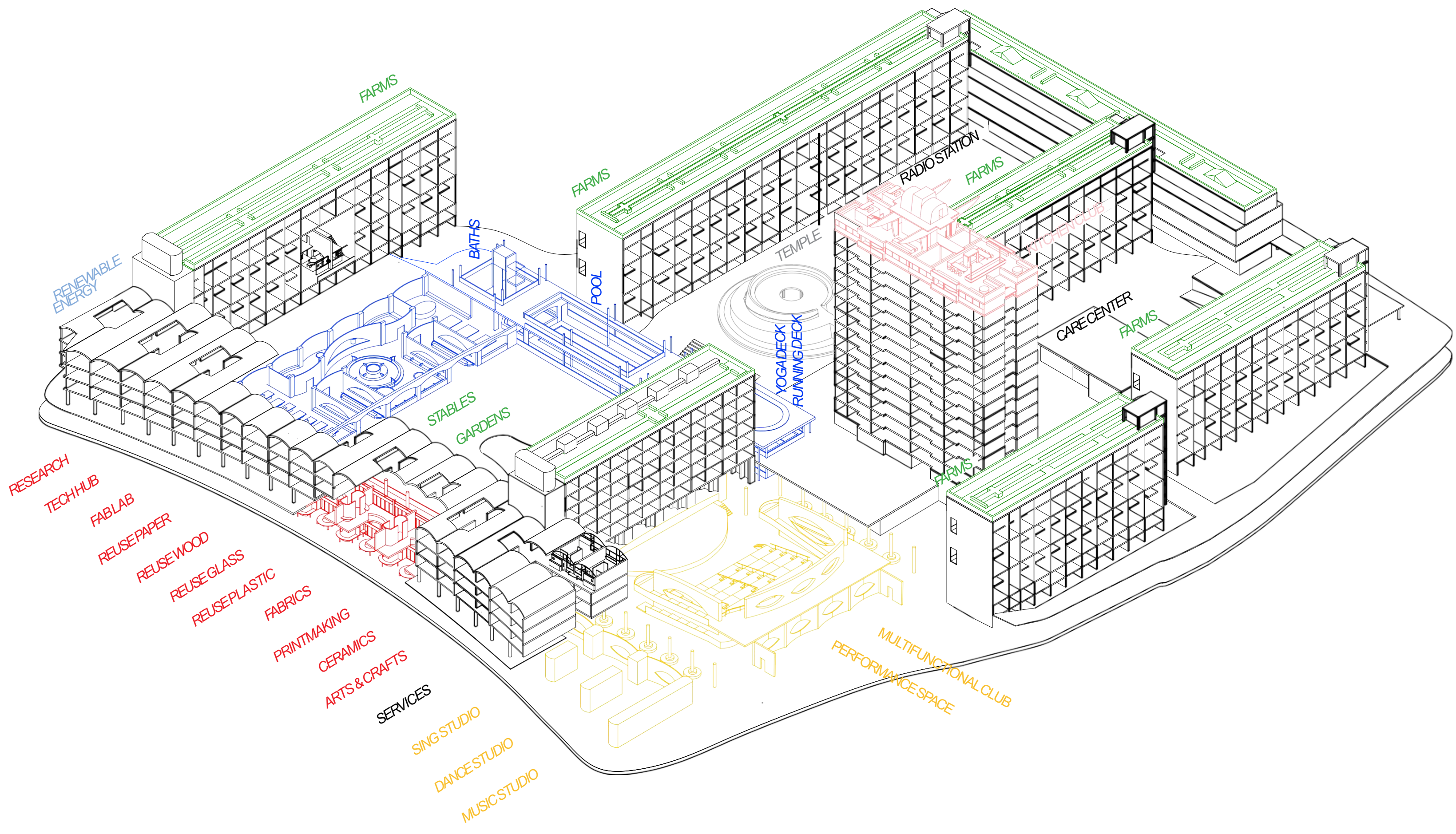

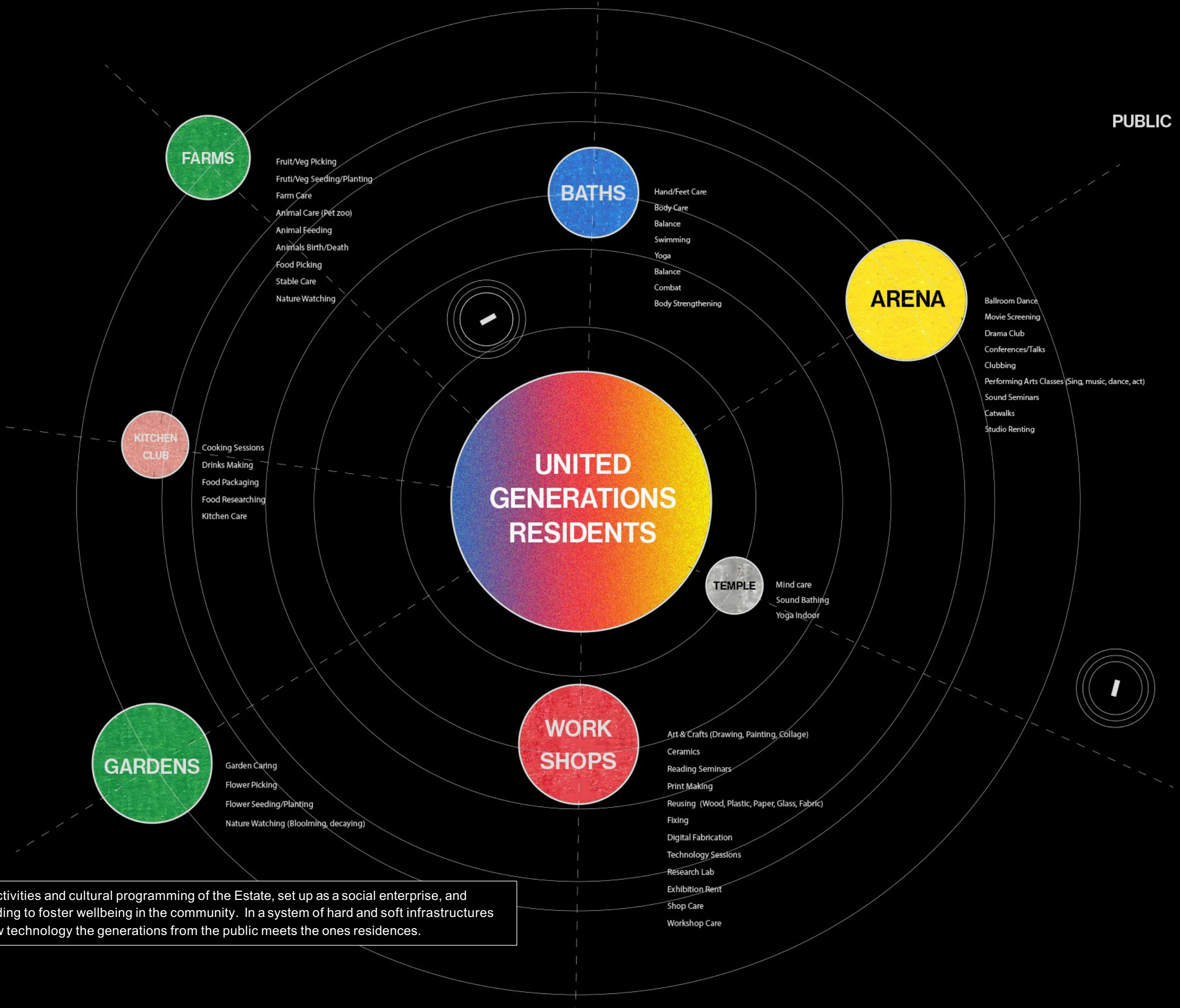

A third scheme imagines the activities and cultural programming of the Estate, set up as a social enterprise, and subsidized by government funding to foster wellbeing in the community. In a system of hard and soft infrastructures advertised through old and new technology the generations from the public meets the ones residences.

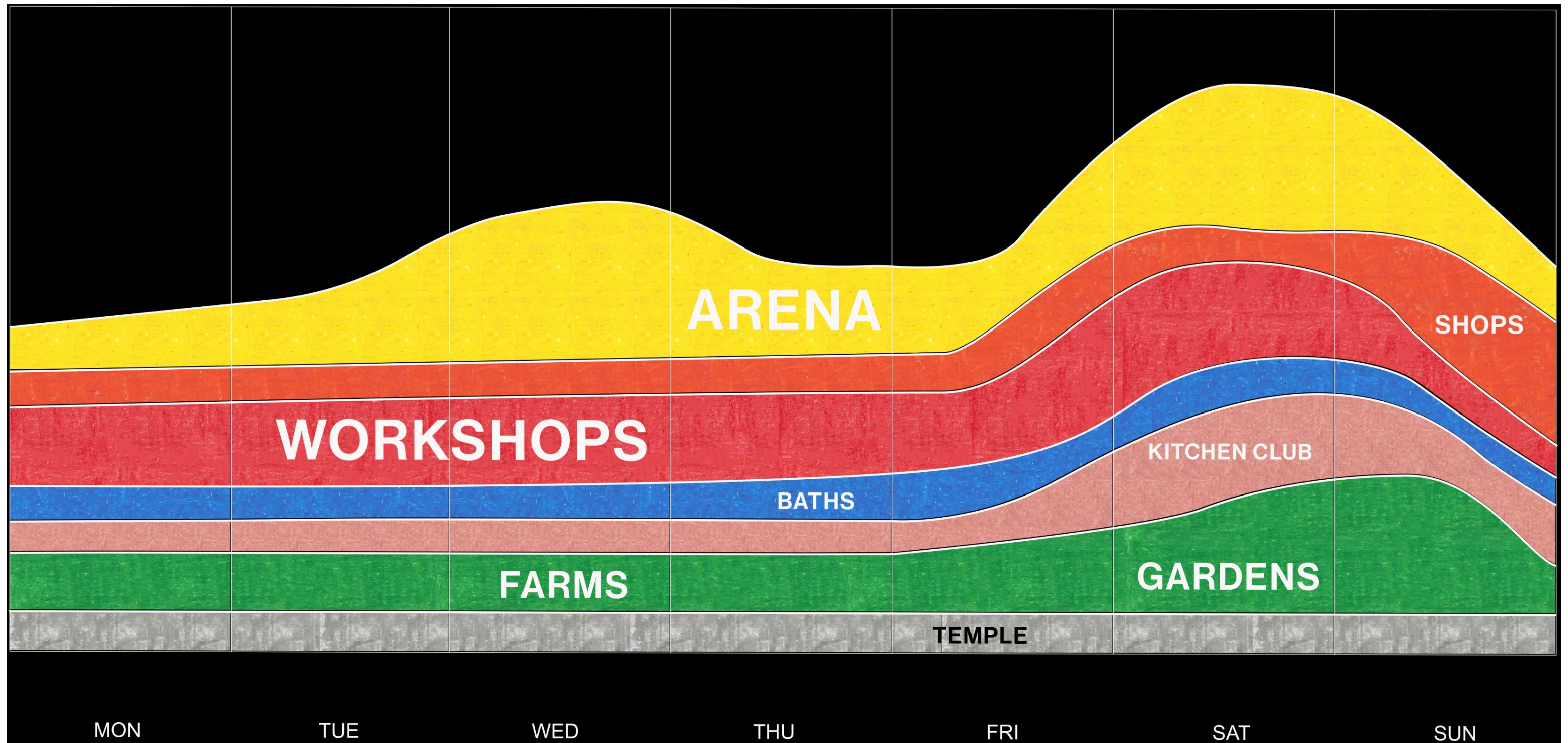

The soft infrastructure achieves maximum use of the hard infrastructures during the weekly and daily cycle. Each space has its own flexible and fixed programs, and adaptability is a key element. When not in used it can be rented to third party.

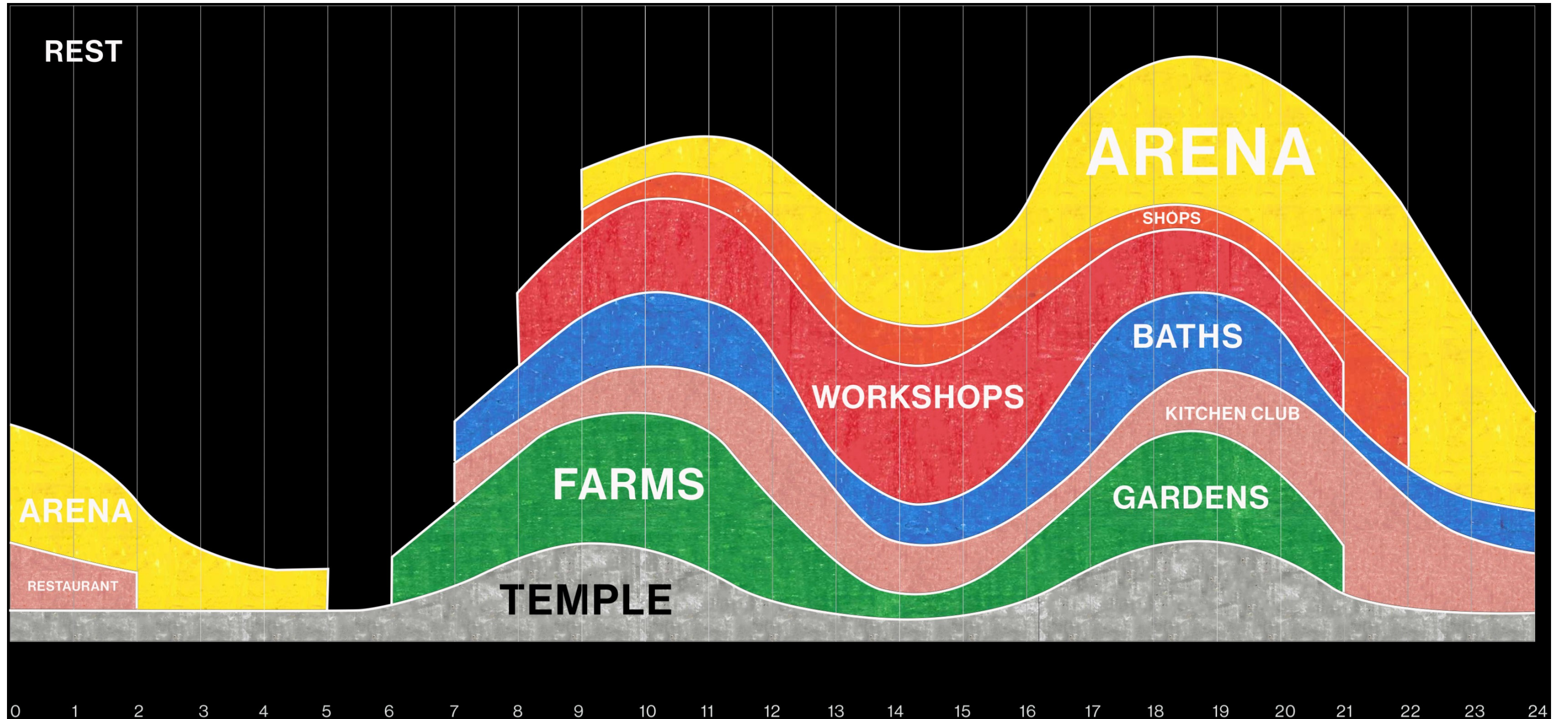

The soft infrastructure achieves maximum use of the hard infrastructures during the weekly and daily cycle. Each space has its own flexible and fixed programs, and adaptability is a key element. When not in used it can be rented to third party.

DAILY ASSEMBLAGE OF ACTIVITIES - BATHS AND GYMNASIUM

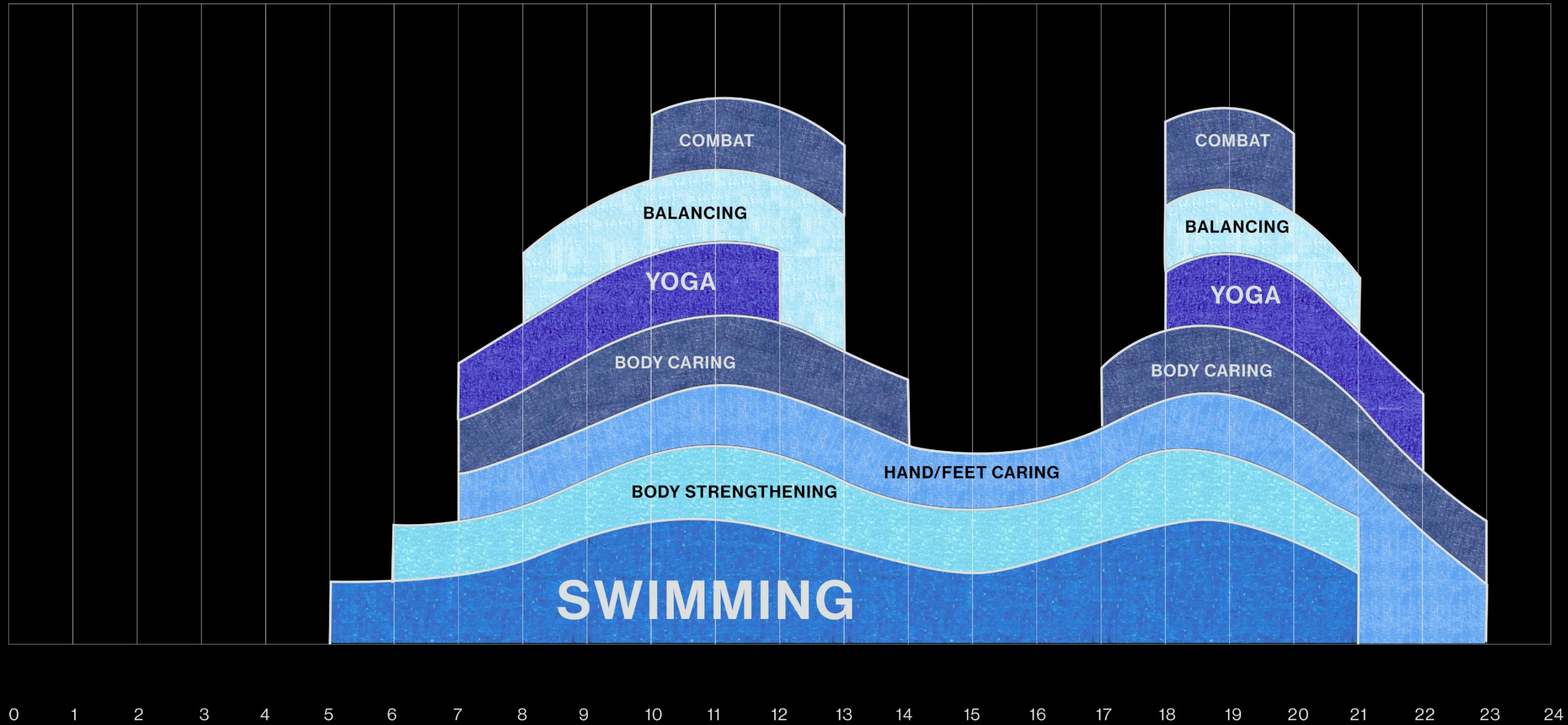

The soft infrastructure achieves maximum use of the hard infrastructures during the weekly and daily cycle. Each space has its own flexible and fixed programs, and adaptability is a key element. When not in used it can be rented to third party.

The pairing nature of the activities nurture the interaction between one or more generations creating opportunities for exchange, learning and producing an outcome that will feed the circular economy of the community.

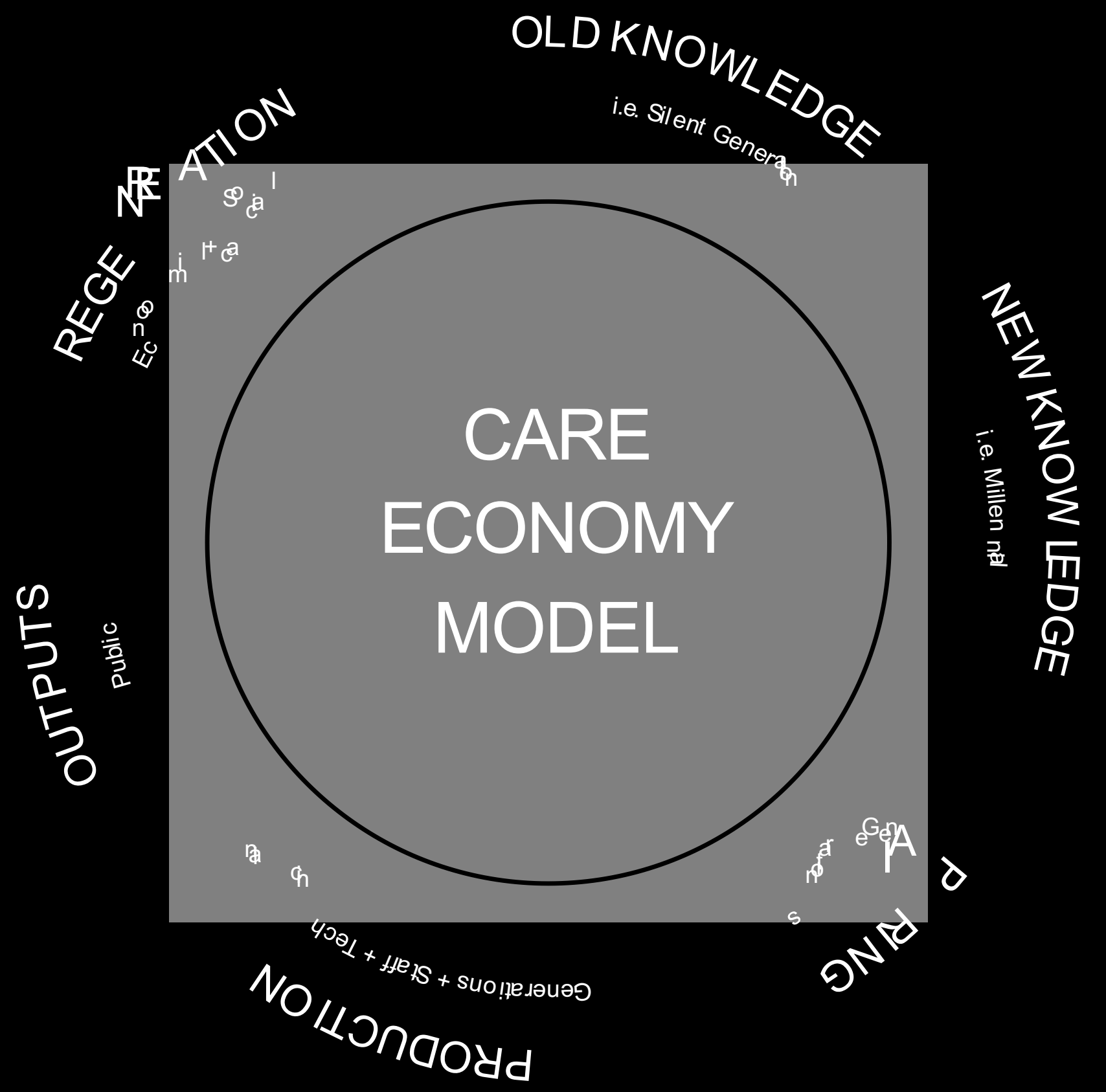

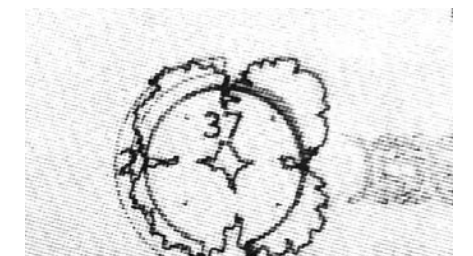
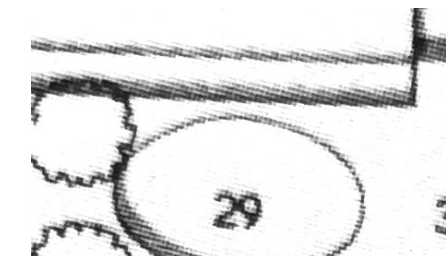
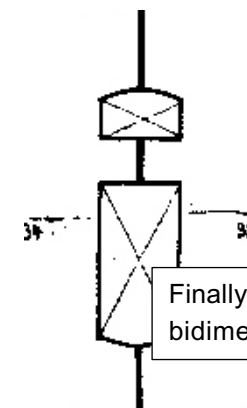
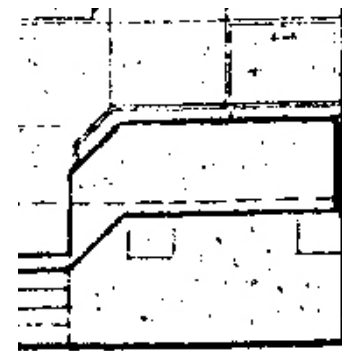
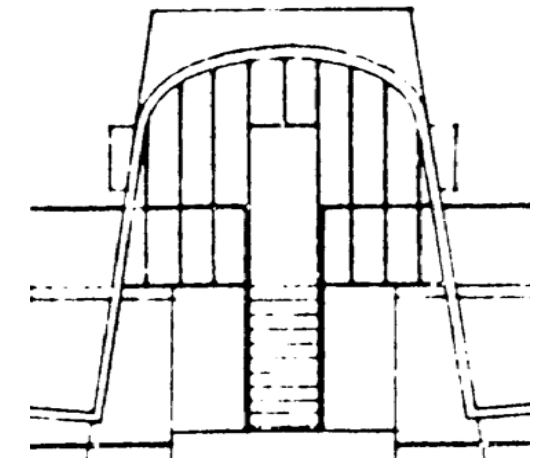
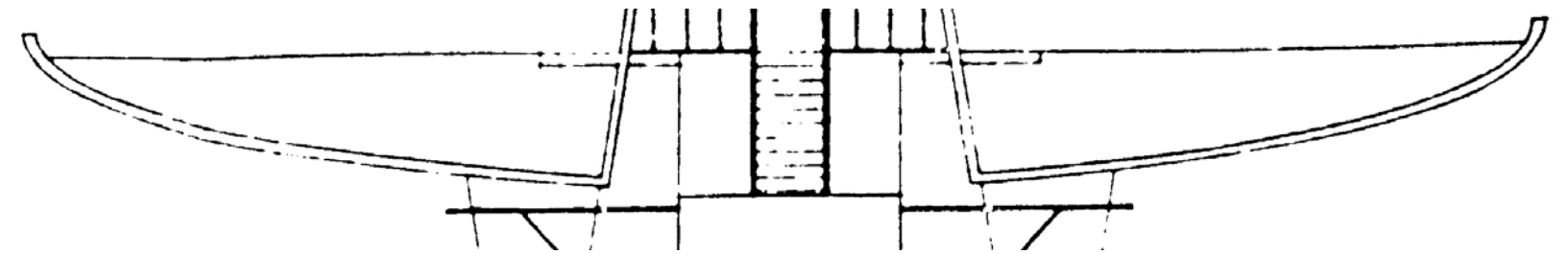
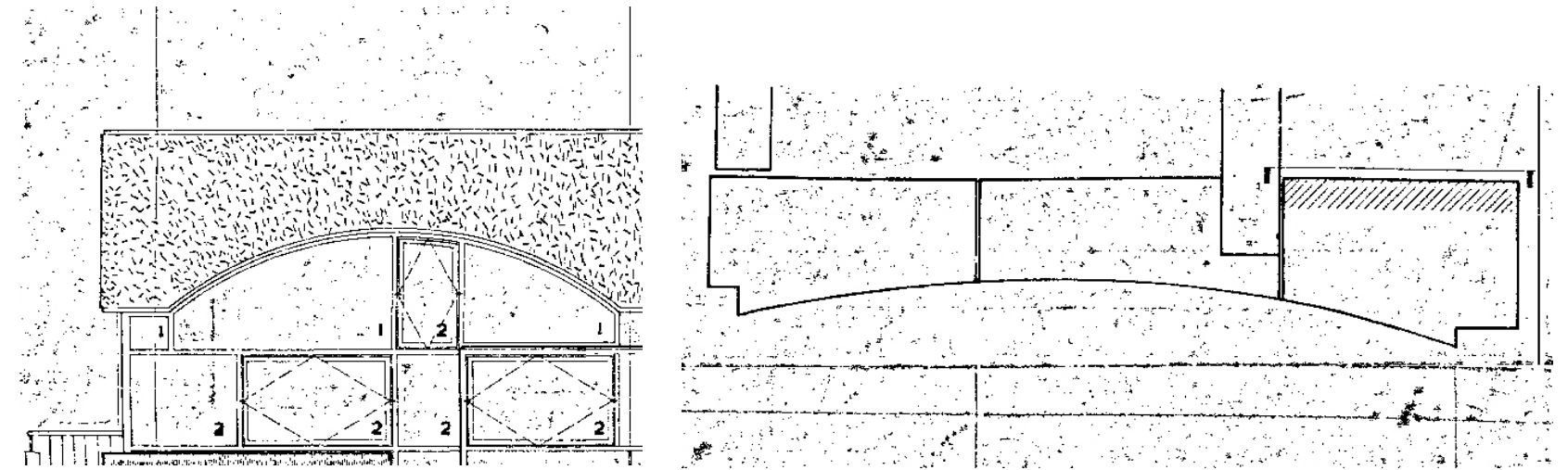

Finally I made a strict inventory of the building visual typologies, I translated them into bidimensional stencils and tridimensional objects with which I could design the spaces.

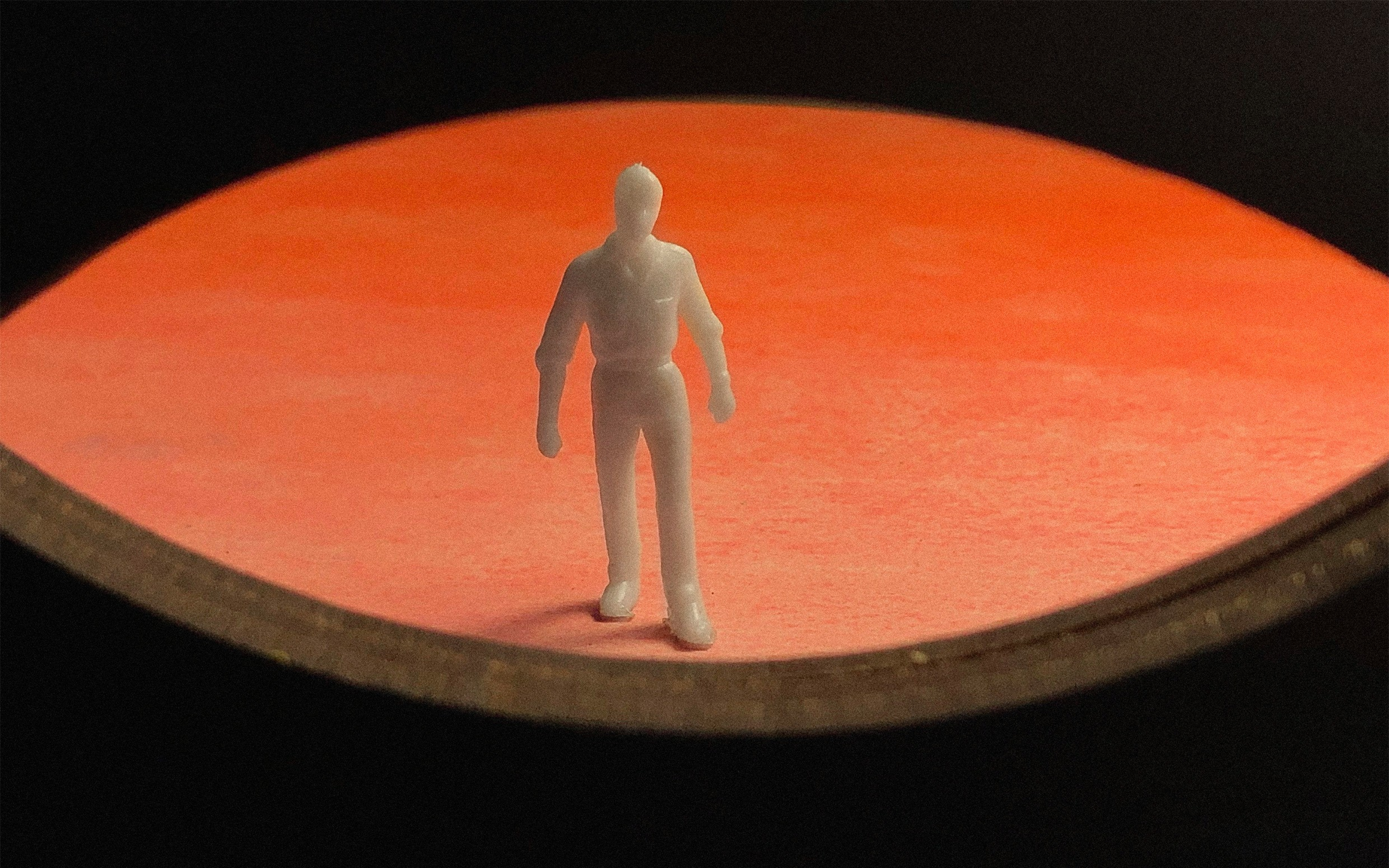

This is the story of a community in a day, in a year, among generations.

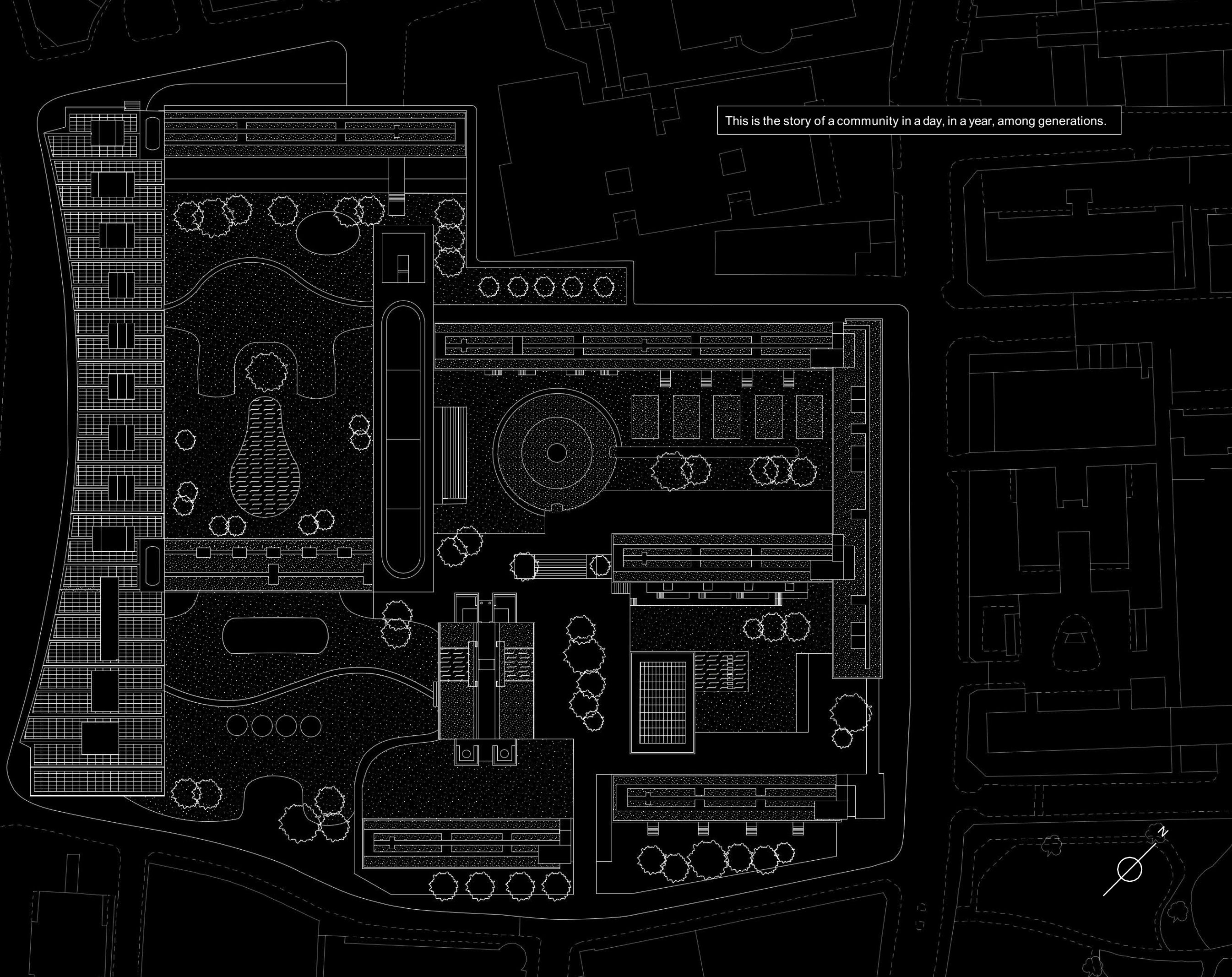

## PROLOGUE

London has changed.

Due to the climate crisis of 2019, the council decided to eliminate vehicles from the high streets turning them into green space. The 2020 pandemic made metropolitan citizens rethink their shared spaces. Larger spaces for new and old generations, Essential spaces. Spaces for conviviality, inclusiveness and learning. Important spaces. Under these circumstances, The Golden Lane Estate transformed into Arcadia: families, children and grandparents co-living with other species of plants and animals in a sustainable and natural environment.

Hills emerged from the urban fabric. The rural urbanism is here. Wildlife became part of the new normality. Communities regenerate and the Care Economy is intrinsic.

## THE RESIDENTS

Each one finds their own dimension here. There is space for independence but also for growth. Those who find their home here will not leave soon. They come here for the dream of settling while expanding their domestic environment where necessary. Families expands and shrink as the residences do.

## APARTMENTS

The ADS allows residences to host from 1 to 8 people family. The apartments offer moments of connections on the communal pathways, buffer zones between domestic and public. Enriched with soft chestnut benches with armrest for the elders and spaces for plants to populate the voids. Animals are always welcome here. Those families who chose to adapt their apartment perforating the existing walls they gather on the interior balconies, transformed into communal spaces.

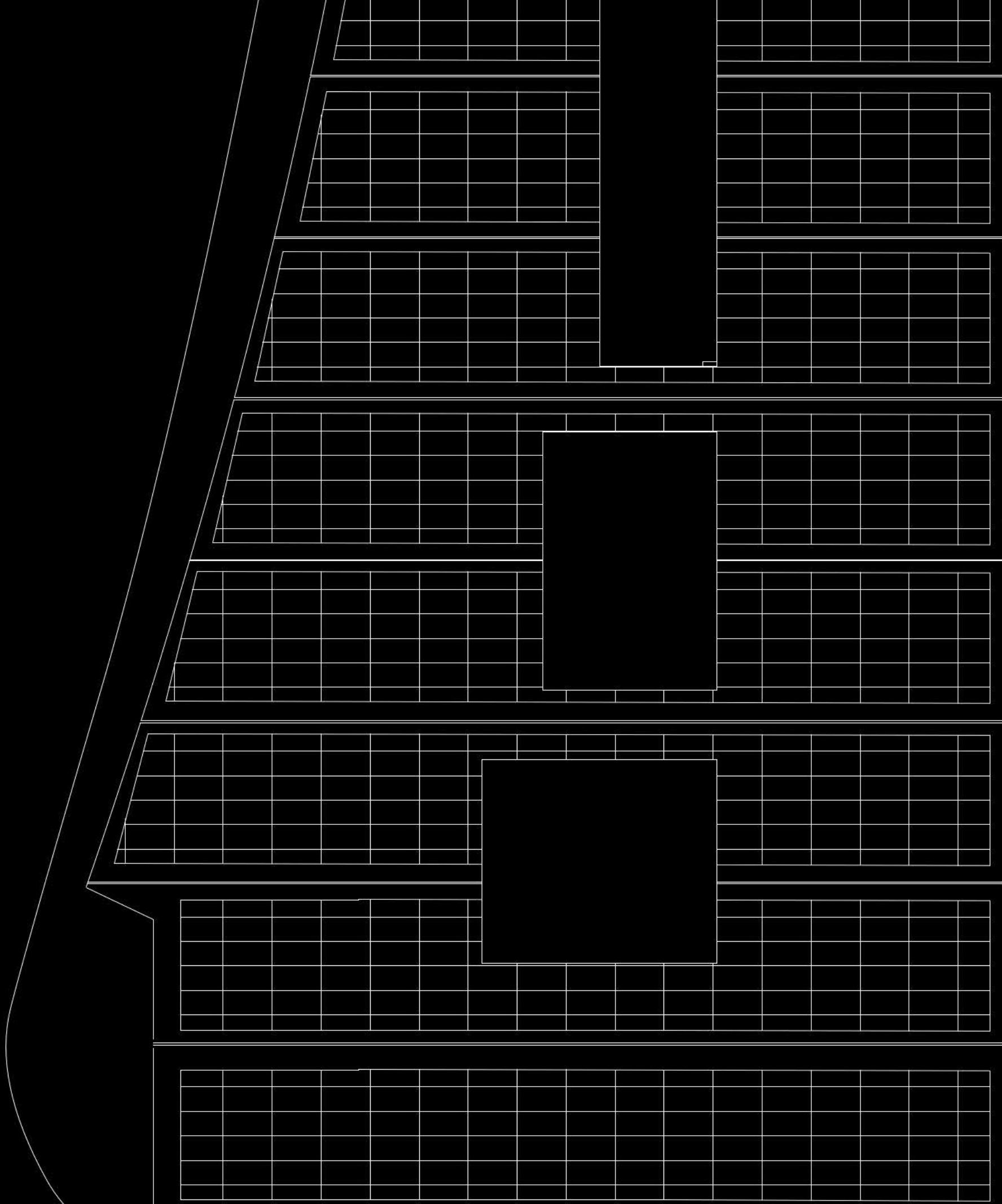

## Crescent House Residences

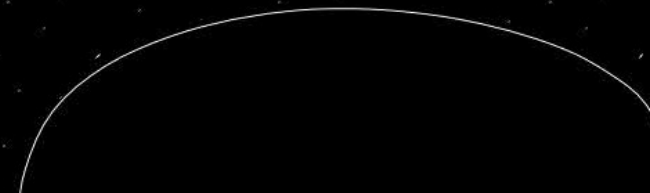

It all starts on a bench. A friendship bench outside the apartments on a autumn morning. The neighbours here pause, talk, and build relationships.



key

- 1. antislippery floor
- 2. chestnut wood with eco-varnish bench
- 3. chestnut handles and rail
- 4. recycled aluminium flowerpot
- 5. 3D printed embossed bioplastic family plaque
- 6. solar panels on wild moss cladding

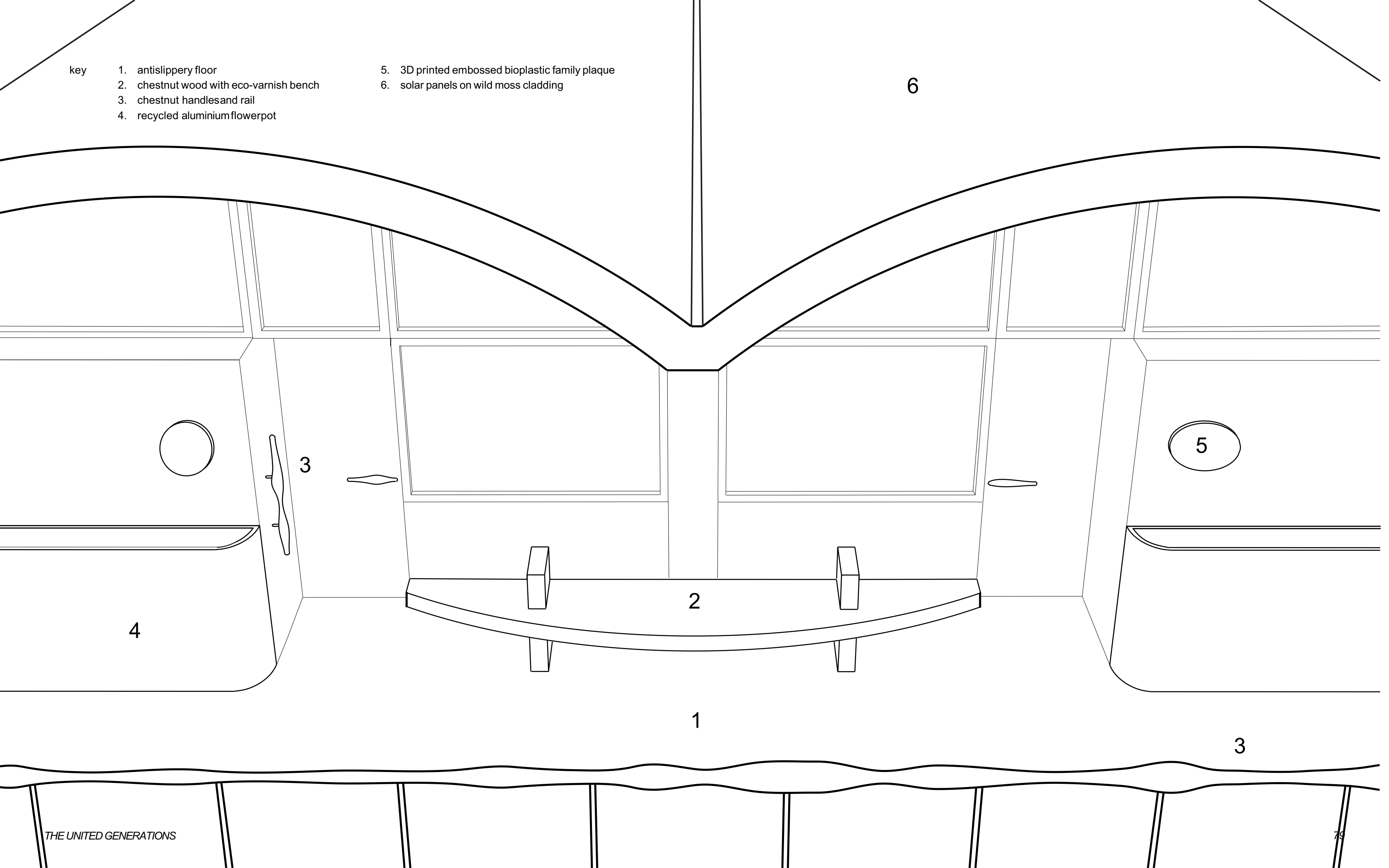

key

1. interior shared balcony to promote independent growth
2. independent sliding door allow privacy in both residences.
3. exterior shared bench to promote residents community growth in semiprivate buffer zones.

4. accessories: personalized handles and grab holder, family plaque instead of numbers.
5. embedded flowerpot to support green culture.

TYPICAL MERGED  
APARTMENT LAYOUT

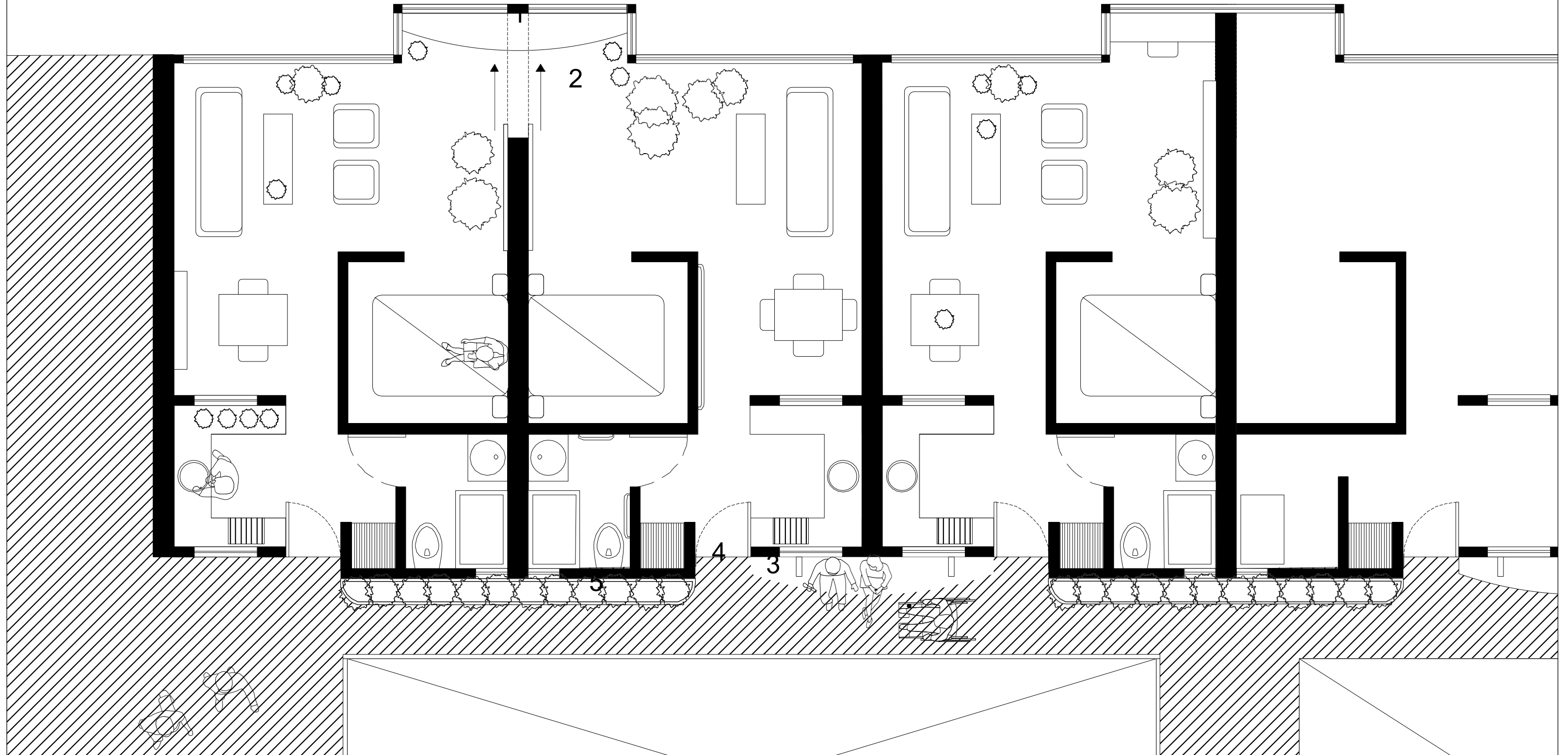

The Work/Shops

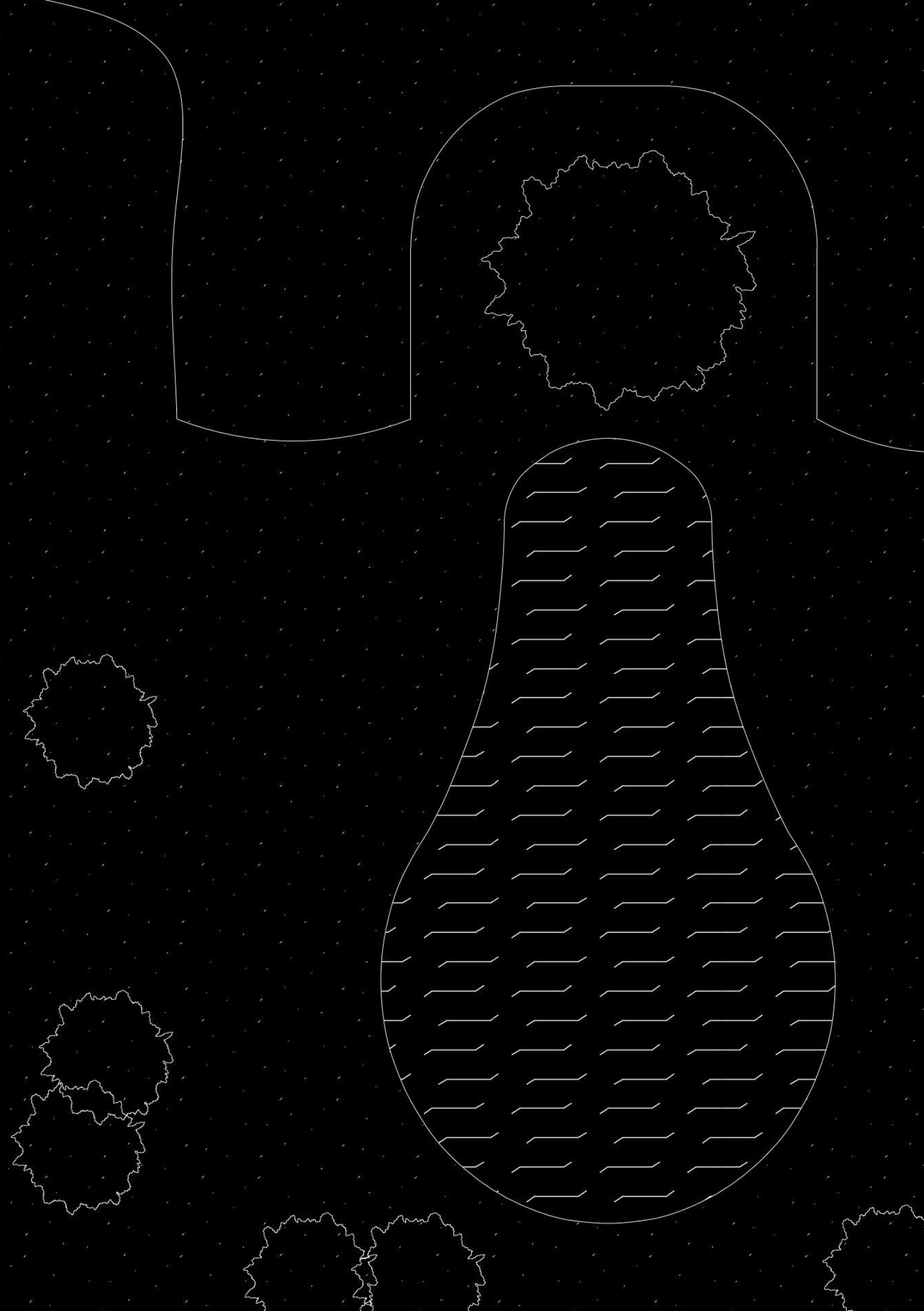
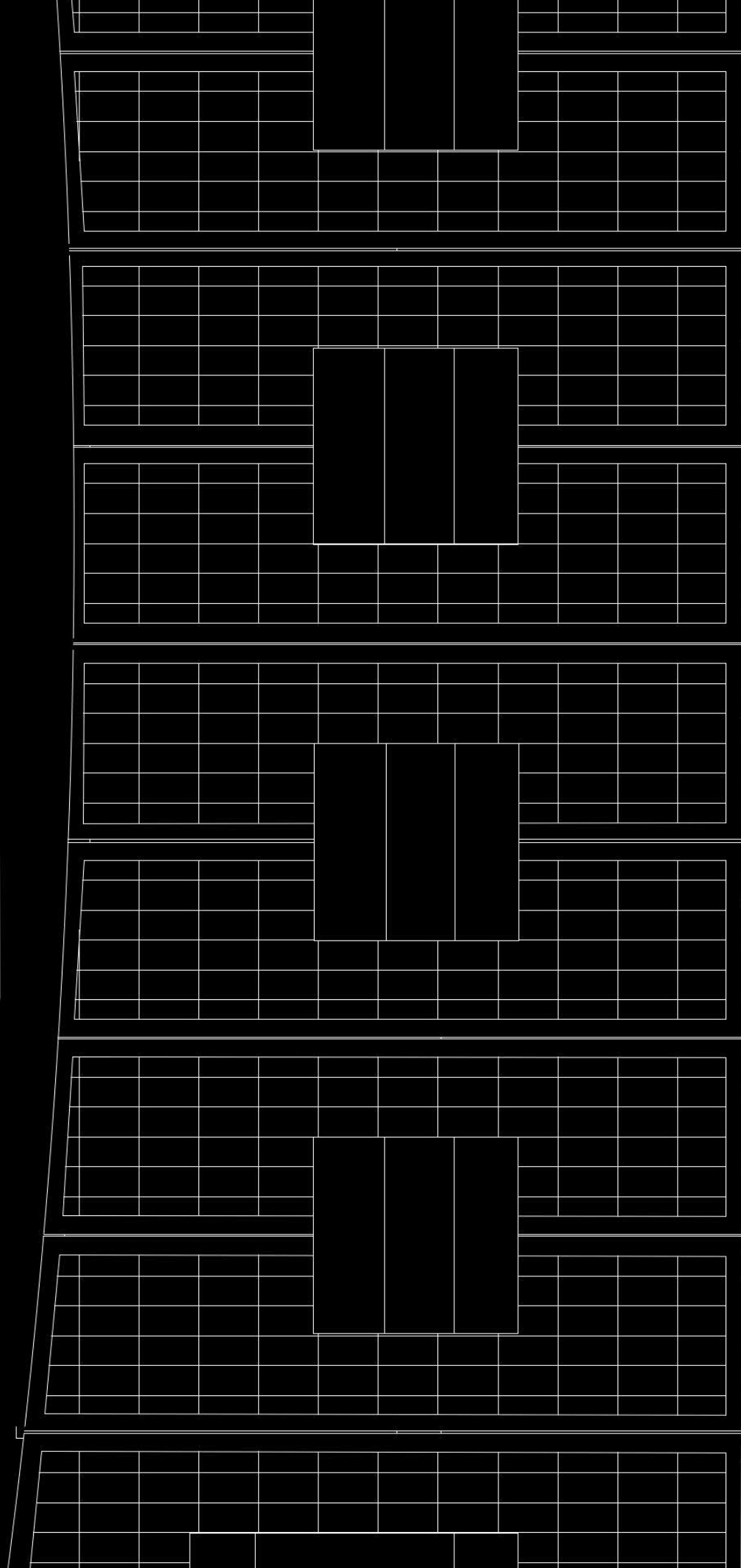

## THE WORK/SHOPS

The Work/Shops are a strip of converted retail spaces each containing an activity based on the notion of art, reuse, and technology. The workshops in residence are: art&crafts, ceramics, printmaking, reuse, digital fabrication, technology and research. Conceived as permeable spaces, they connect the main street of commerce to the heart of Arcadia. Accessible for young and old, they foster productivity, exchange and learning. The residents run the laboratory spaces which can be used to produce items sold on the ground level to feed the circular economy of the community or to rent it out to third public parties for classes and events when the spaces are not in use. The workshops as the farms and kitchen are the core of the Estate intergenerational exchange. Paired with volunteering older members, and assisted by staff technicians the young generations come here to make and learn.

## THE STABLES

Chickens, sheep, pigs, cows, donkeys and lamas overlook the busy workshops from the strip of stables. This unused underground space is converted into a shelter for a farm pet zoo. Residents and public come here to care for the animals. They pet, feed, give birth and assist death the other species for a day, a month, a lifetime. Humans and animals learn from one another. The understanding of the cycle of life and the rules of nature begins here.

## GARDENS

The watering hole, is the center of a thriving natural ecosystem flourishing every season around the water. Seasonal wildflowers, fruit trees, herbal plants and shading trees create the perfect home for people and wild animals. Meadows of wild grasses run up the adjacent hills creating a long continuous green tongue.

Winter is here. A strip of adaptable spaces dedicated to the disciplines of art&crafts, reuse, and technology run by the same residents is host an exchange of teaching, learning and economic values. The workshops are flexible work and retail spaces where the products generated are sold to feed the economy of the community.



key

- 1. walnut adjustable and movable working table
- 2. new wooden foldable door
- 3. walnut displaytable
- 4. walnut displayshelf
- 5. embossed recycled metal signage
- 6. original polished tilefloor
- 7. chestnut customized handrail
- 8. original restored windows

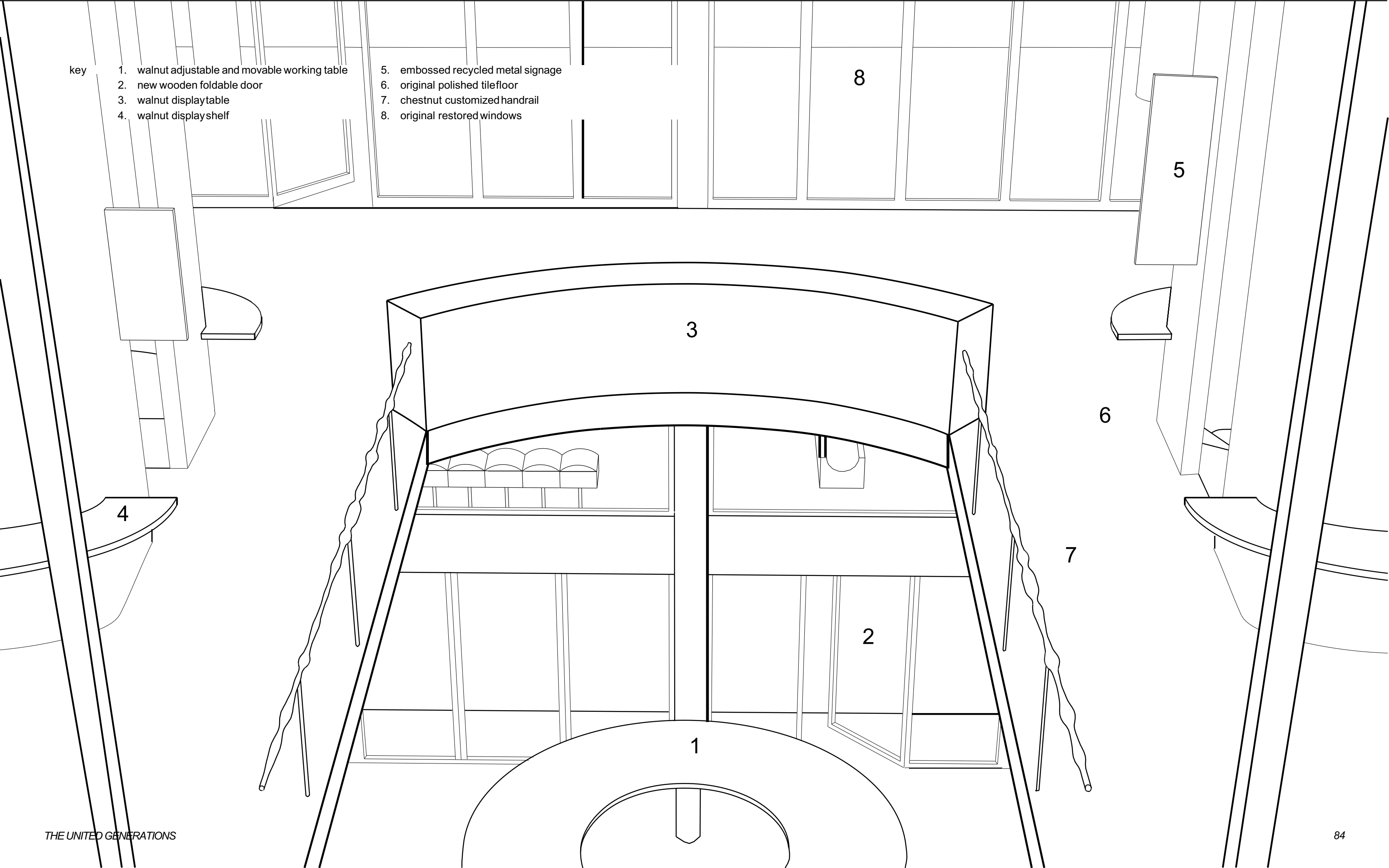

key

- 1. shared adjustable and movable working surfaces.
- 2. meeting pod to promote conversations and privacy.
- 3. showcase shelves for exhibitions, display and sale.
- 4. vertical circulation between shops and laboratories through spiral stairs and hydraulic platform.
- 5. owners private residences connected to work/shops

WORK/SHOP  
SECTION

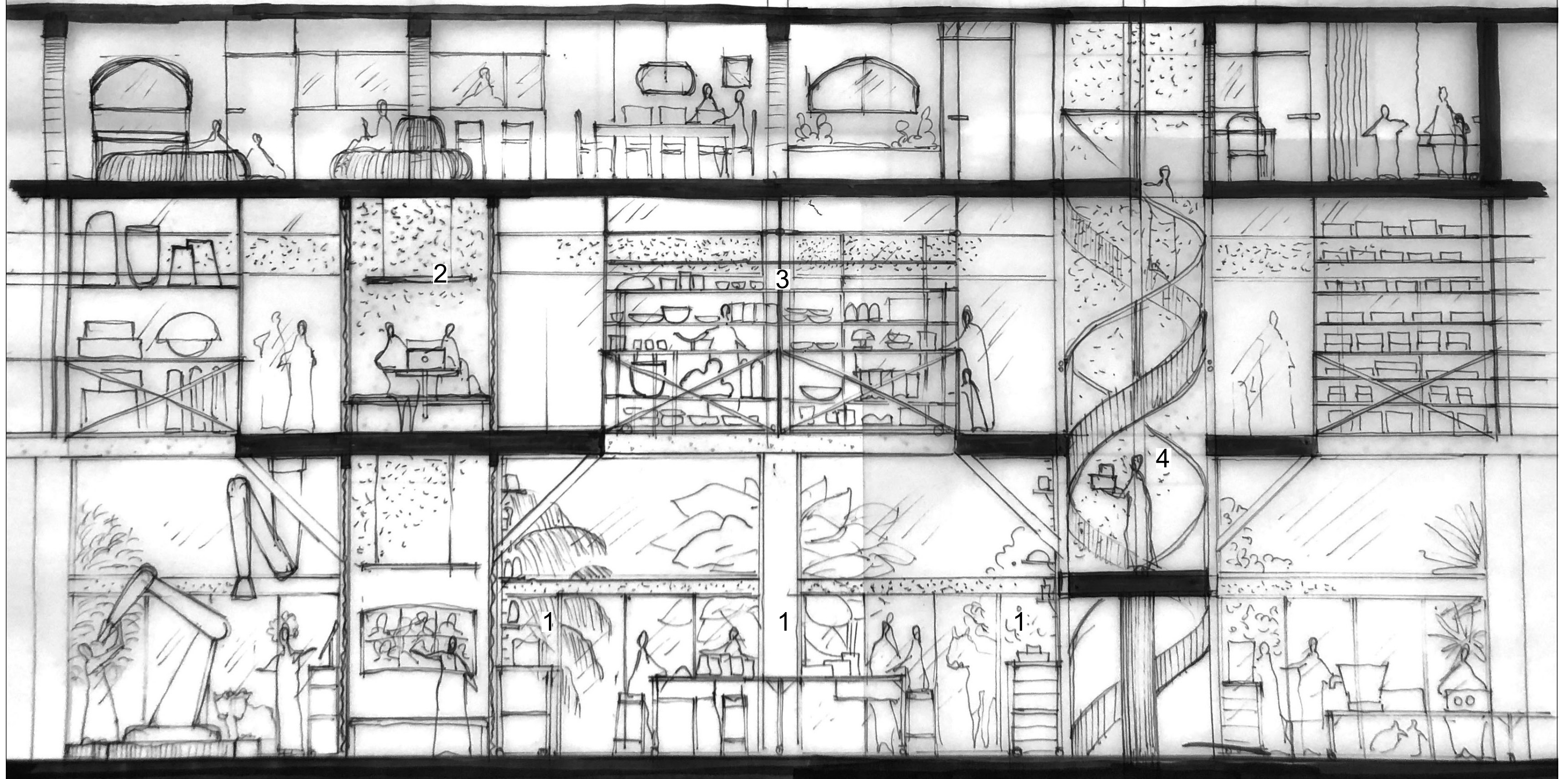

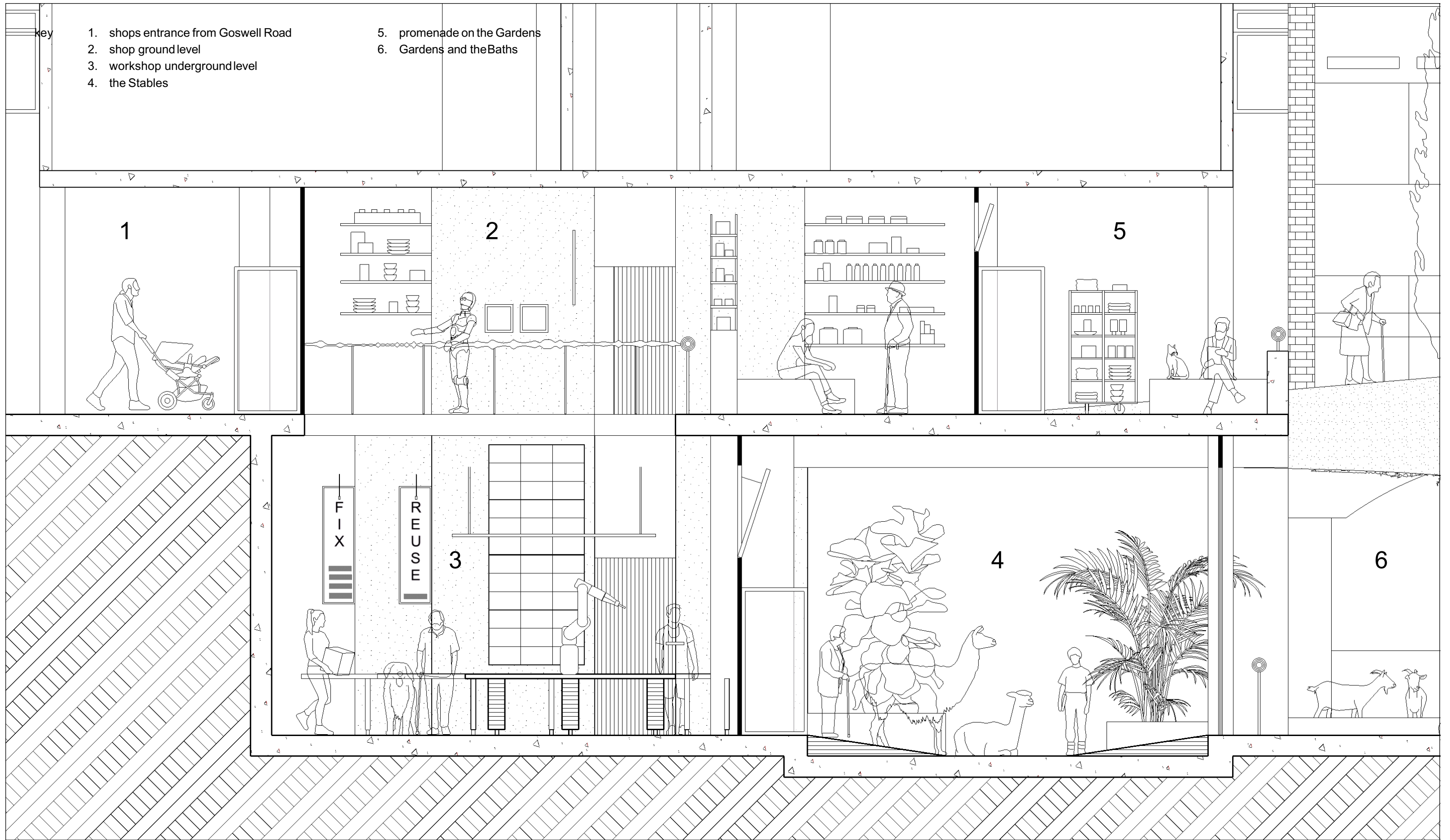

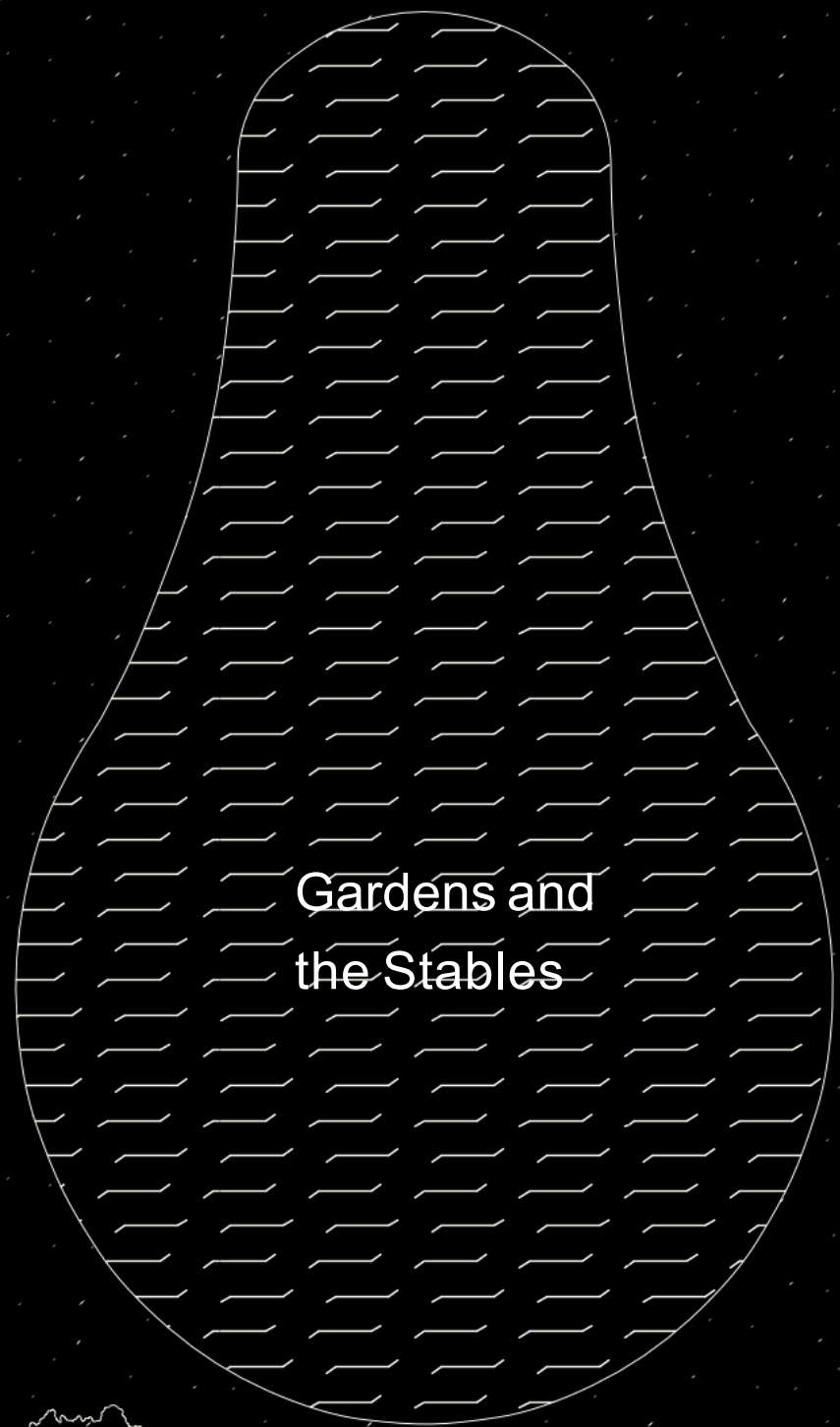
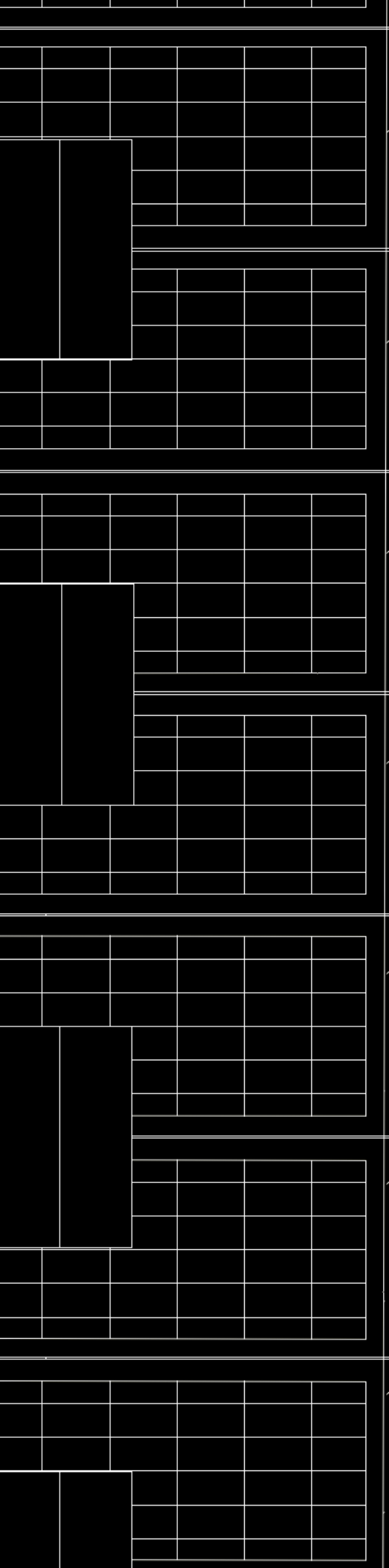

Gardens and  
the Stables

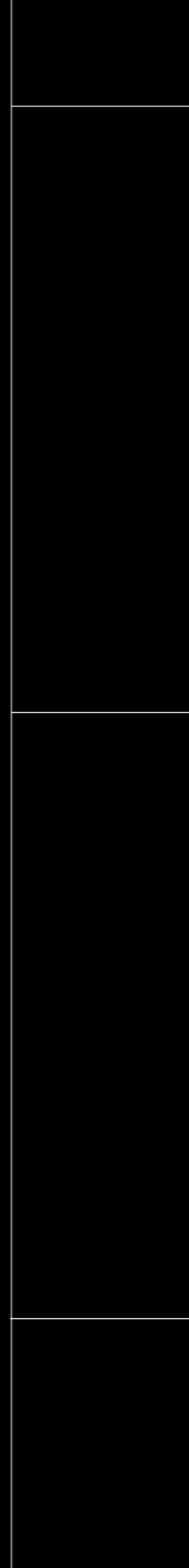
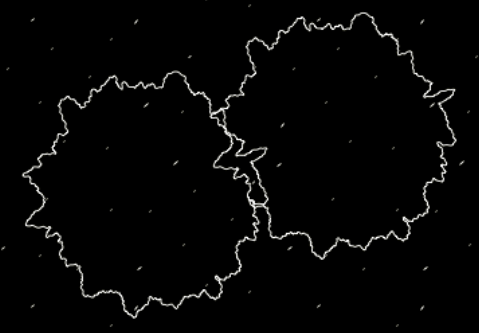
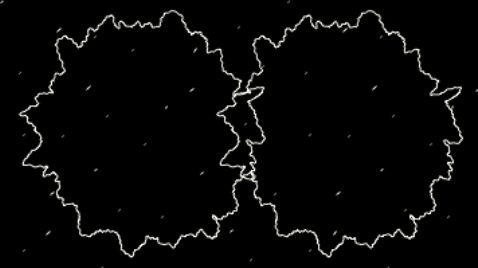
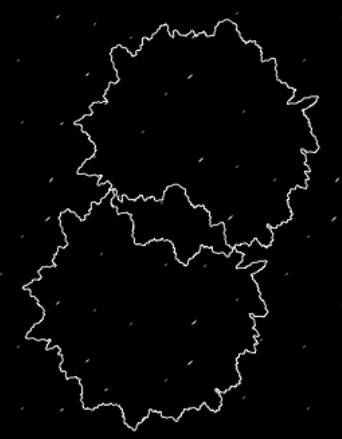
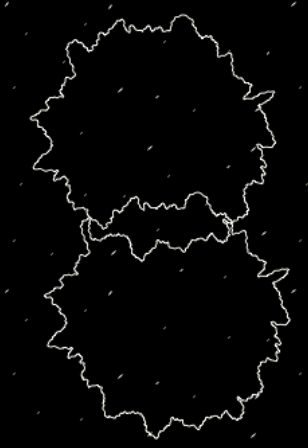

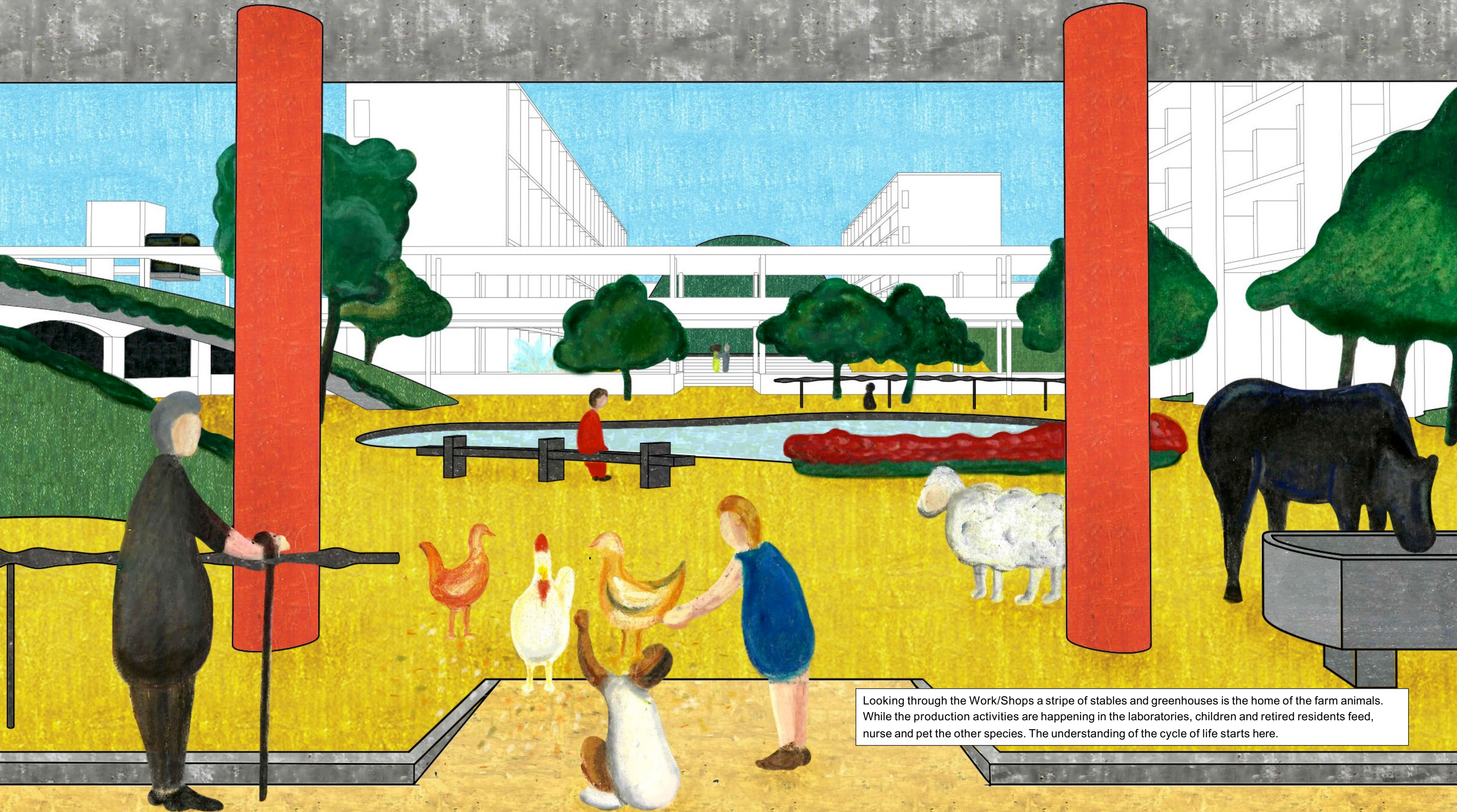

Looking through the Work/Shops a stripe of stables and greenhouses is the home of the farm animals. While the production activities are happening in the laboratories, children and retired residents feed, nurse and pet the other species. The understanding of the cycle of life starts here.

The Stables open up to the Gardens. Between the hills a watering hole emerge in a valley of wild-flower fields, fruit trees, and medical herbs. The benches offer a moment of rest, performance or exchange. Thanks to the seasonal natural landscape, during the year young and old go blooming watching, picking, and seeding.

key to gardens landscape

- wisteria
- british ferns
- poppy
- echinacea
- hypericum
- elderflowers
- chamomile
- valerian
- cornflower
- d. cespitosa
- silvergrasses
- water lillies
- barred horsetail
- lavender
- wild grass
- acacia tree
- poplar tree
- cherry tree
- apple tree
- pear tree

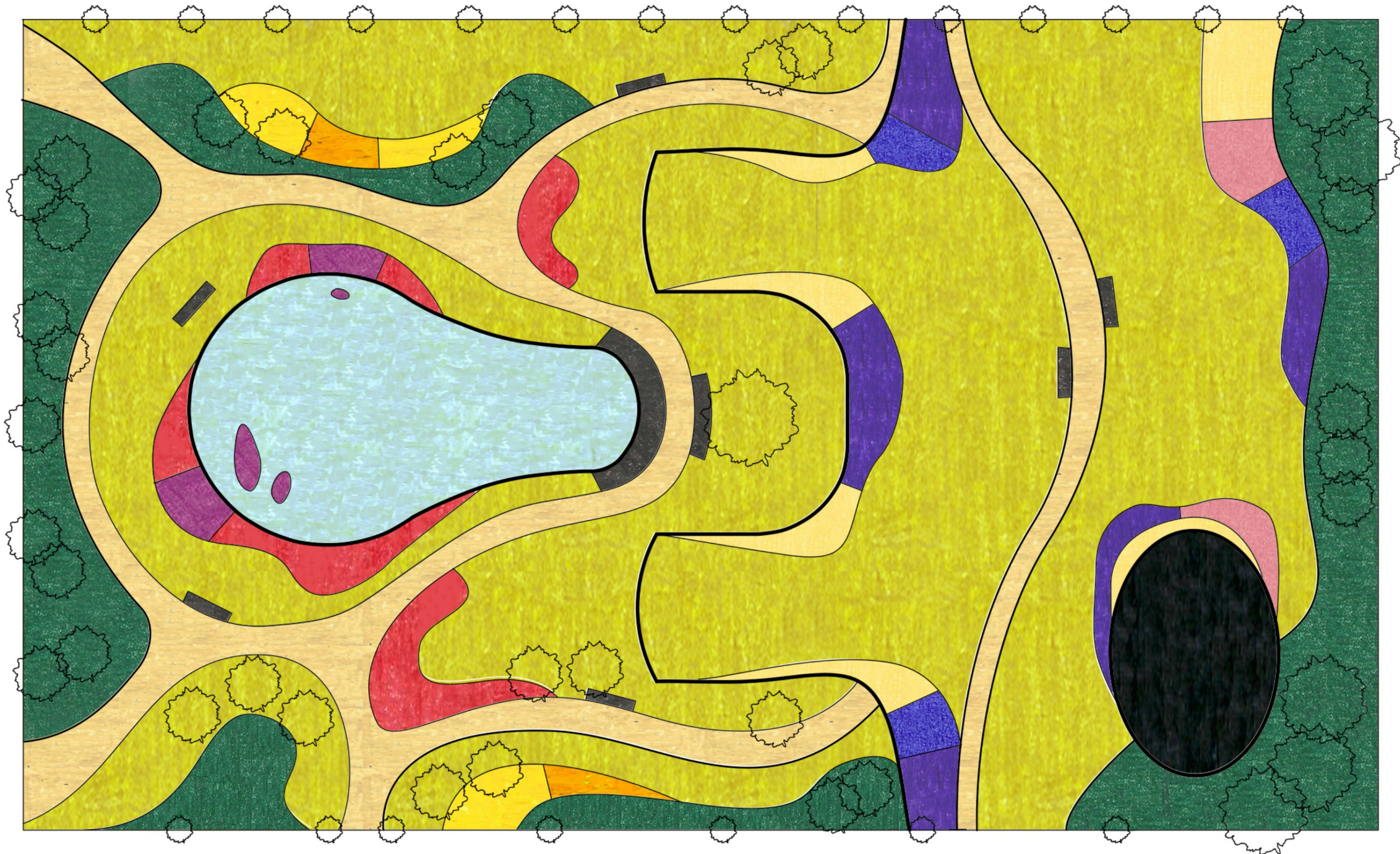

## **THE KITCHEN CLUB**

The panorama terrace has been converted into a place for the performance of cooking and the house of homemade food. Both residents and invited famous retired cooks from all over the world prepare meals for hungry foodies looking for food made with love and great vistas. The elevator brings the guests directly to the top floor where they can choose to dine in underneath a flourishing green pergola in shared or private spaces behind shimmering curtains in the summer and protected by a retractable modular window system during the grey days. Or, the visitors can order or take away food from the warm and refrigerated cells. The digital book of grandmas recipes is an open source encyclopedia of food. When possible, the older women transfer their knowledge to the younger generations continuing the culinary thread. Third party collaborators such as the Company Drinks host here food and drinks workshops. The

ingredients are organic and locally produced, farmed and harvested from the High Farms, the Stables and the Gardens. The income is used to run the kitchen and deliver food to those in need in and outside the Estate.

## **PANORAMA BAR**

The old water tanks of the existing canopy have been converted in shallow pools for sunbathing sipping a cocktail from the tiny engine room bar and listening to the soothing tunes of the United Radio Station on warm dusks and dawns.

## **THE UNITED RADIO STATION**

On the other side of the terrace, two inflatable glossy spheres contain the radio station decks. The radio provide constant information about the activities running in the whole Estate while keeping company to the residents with uplifting ageless music.

The Kitchen Club  
Panorama Bar  
The United Radio Station

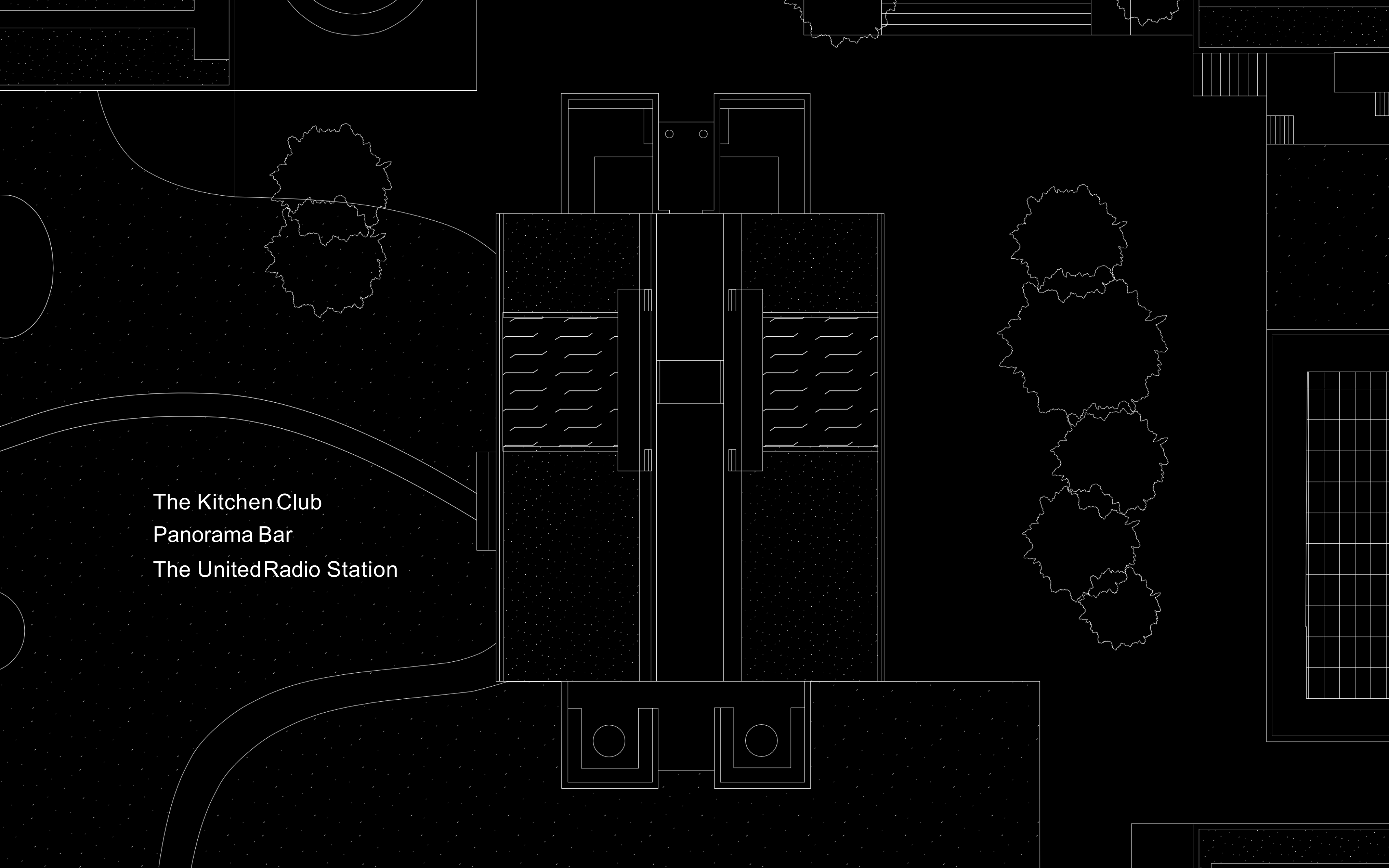

On a bright and windy spring lunch a cooking session is happening in the Kitchen Club underneath the green canopy on the tower. A famous grandma from the public is invited tutor the new learners on how to make pickled vegetables previously hand-picked from the High Farms. The food will be sold to the guests.



key

- 1. chestnut customized handrail
- 2. made-in-estate tiled front desk
- 3. recycled aluminium counter top
- 4. walnut movable working tables

- 5. recycled aluminium flower pot for kitchen herbs
- 6. recycled aluminium columns
- 7. aluminium foil net
- 8. extruded canopy with aluminium profiles covered by mesh

- 9. walnut seating
  - 10. existing granolite concrete flower pot
- to allow growth of vines.

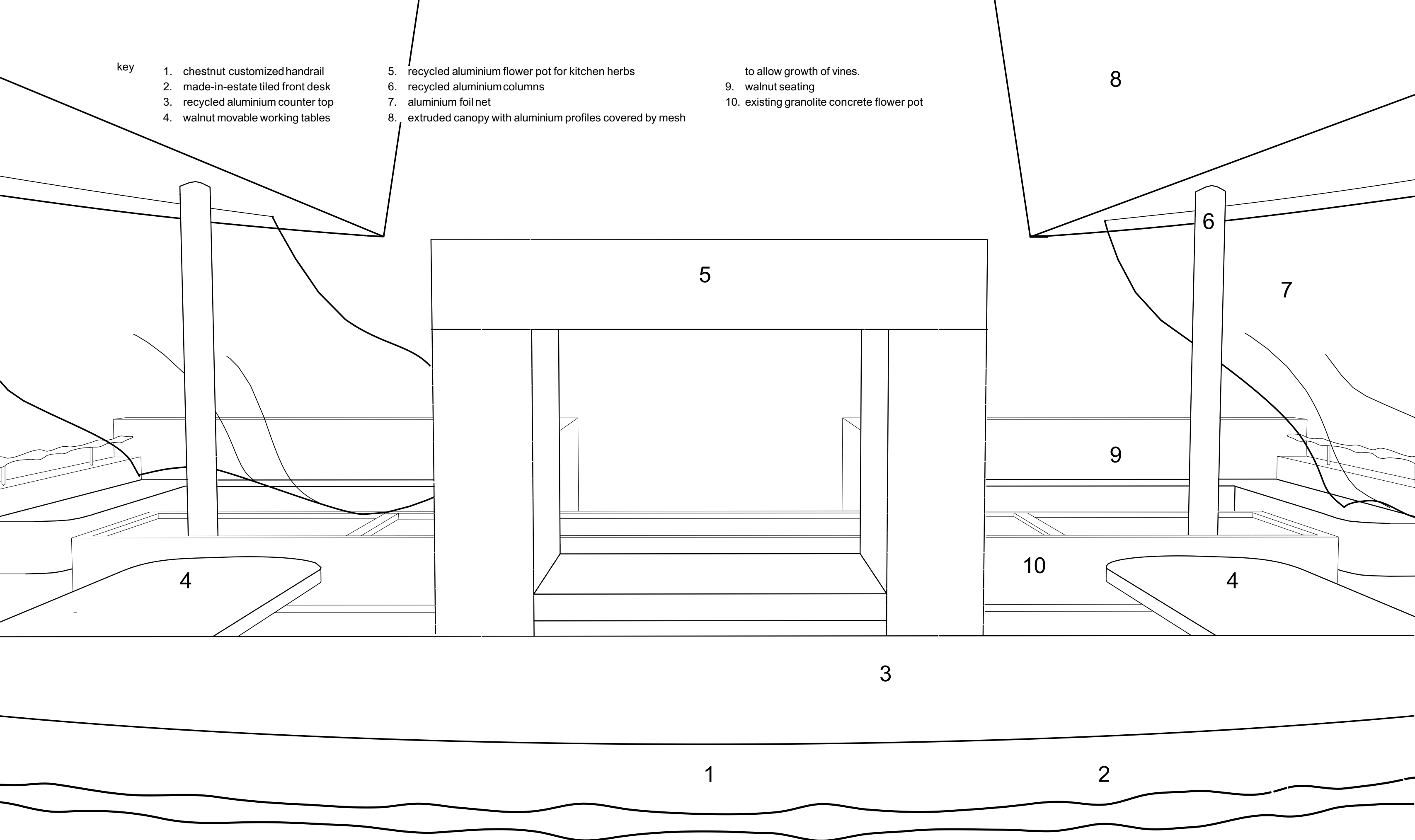

- key
- |   |  |  |   |
|---|--|--|---|
| 1. main entrance through elevators                  | 5. water sink  | 9. communal table with movable screens for privacy       | 13. radio station decks in inflatable bioplastic booths |
| 2. lower pools                                      | 6. existing flowerpot with kitchen herbs                 | 10. WC, services, storage                                |   |
| 3. kitchen counter for food preparation             | 7. communal low seating areas with armrests and cushions | 11. private lounge area with movable screens for privacy |   |
| 4. movable side table for preparation or restaurant | 8. communal high seating areas                           | 12. food/beverages displays                              |   |

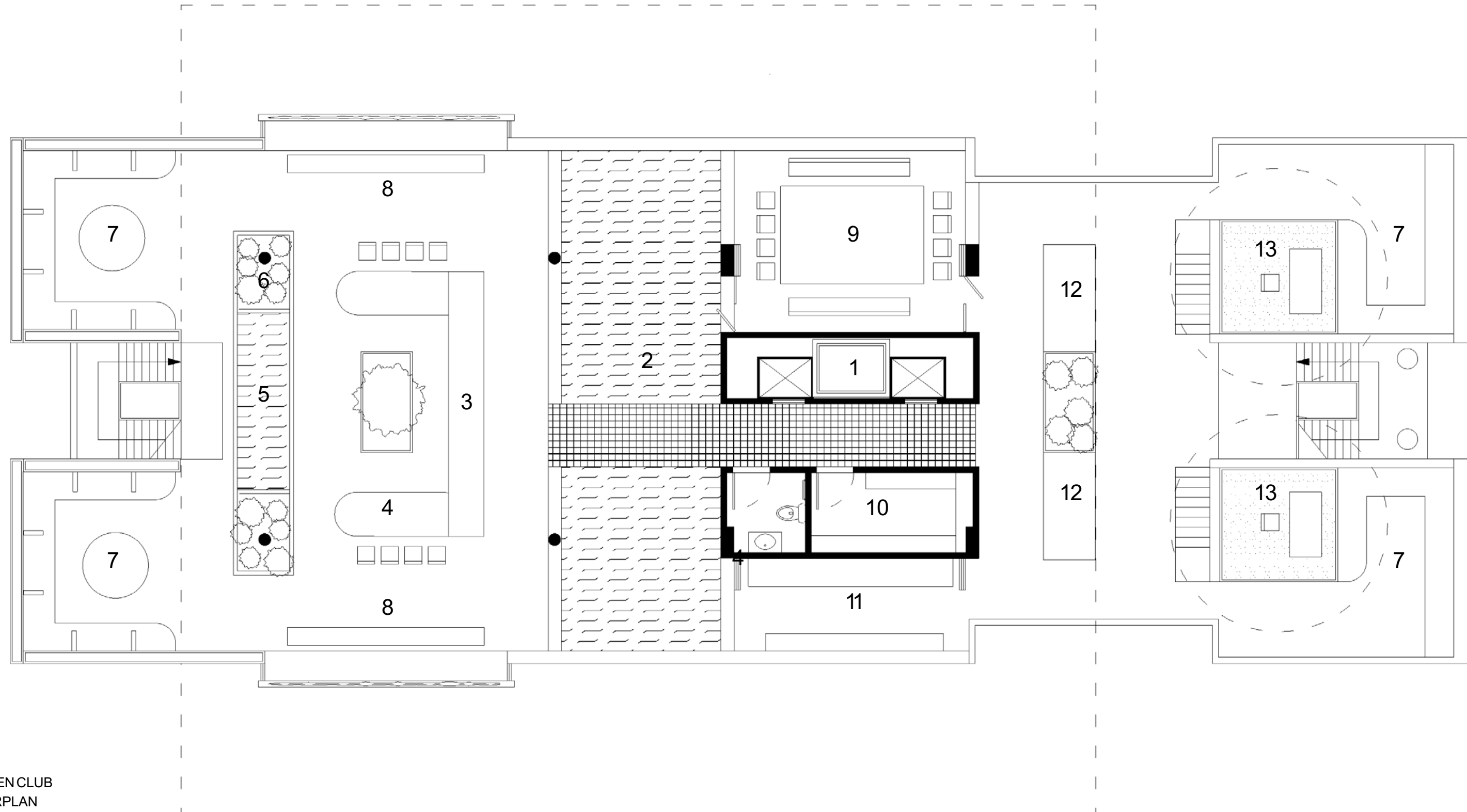

KITCHEN CLUB  
FLOORPLAN

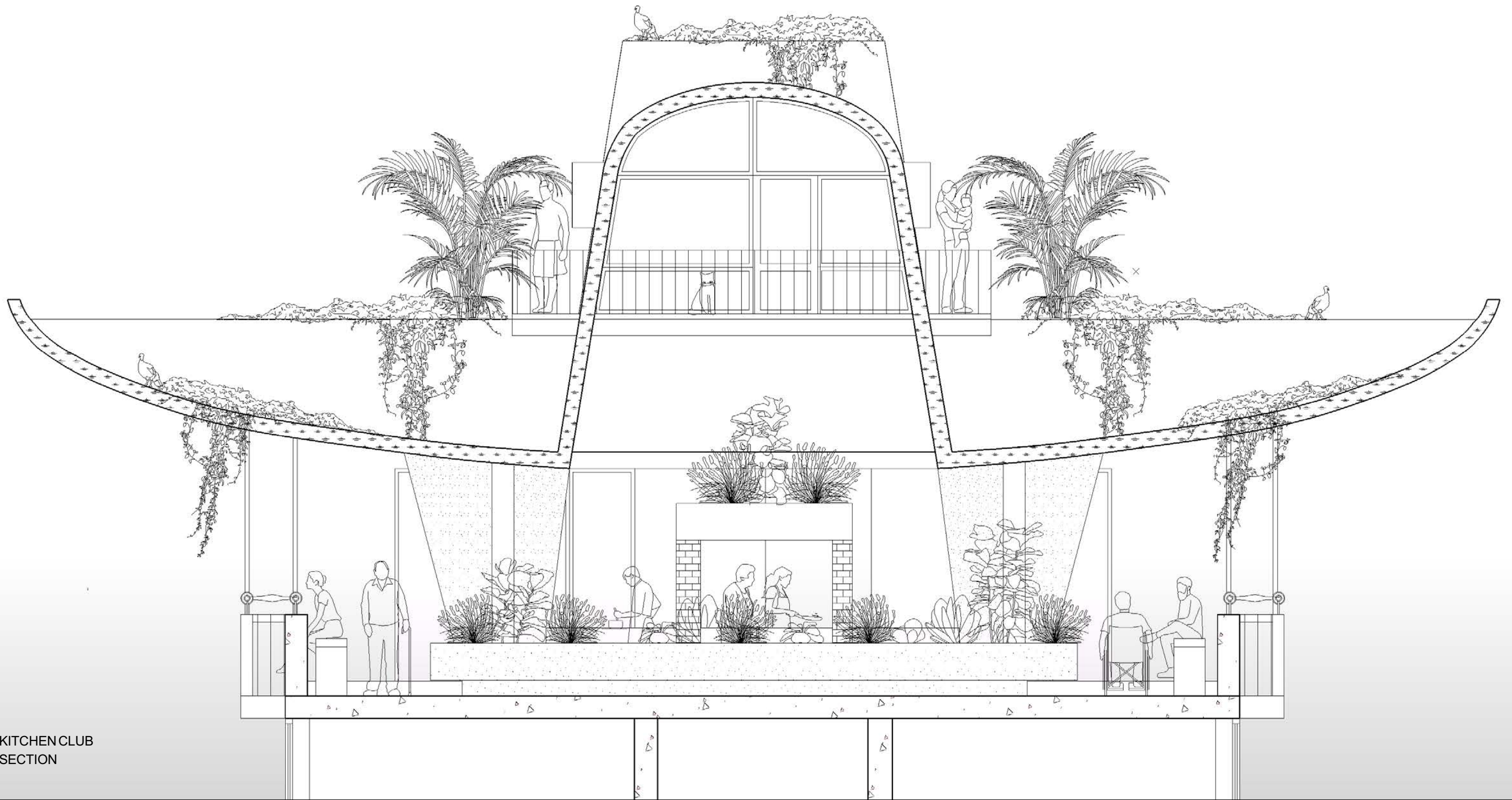

KITCHEN CLUB  
SECTION

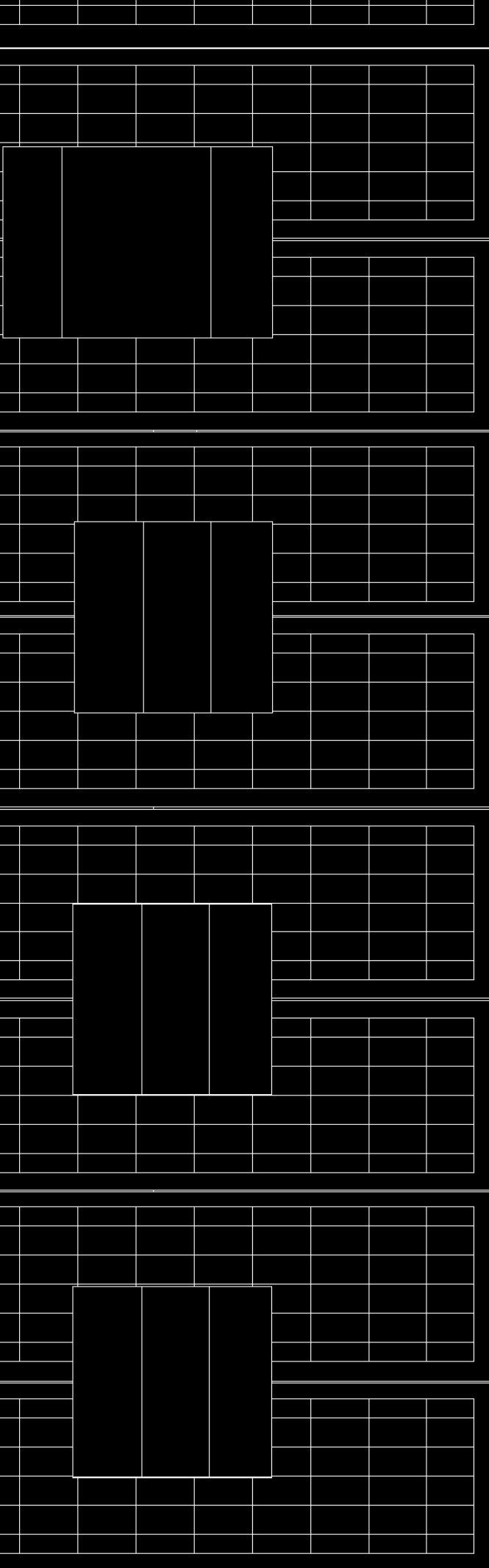

The Baths

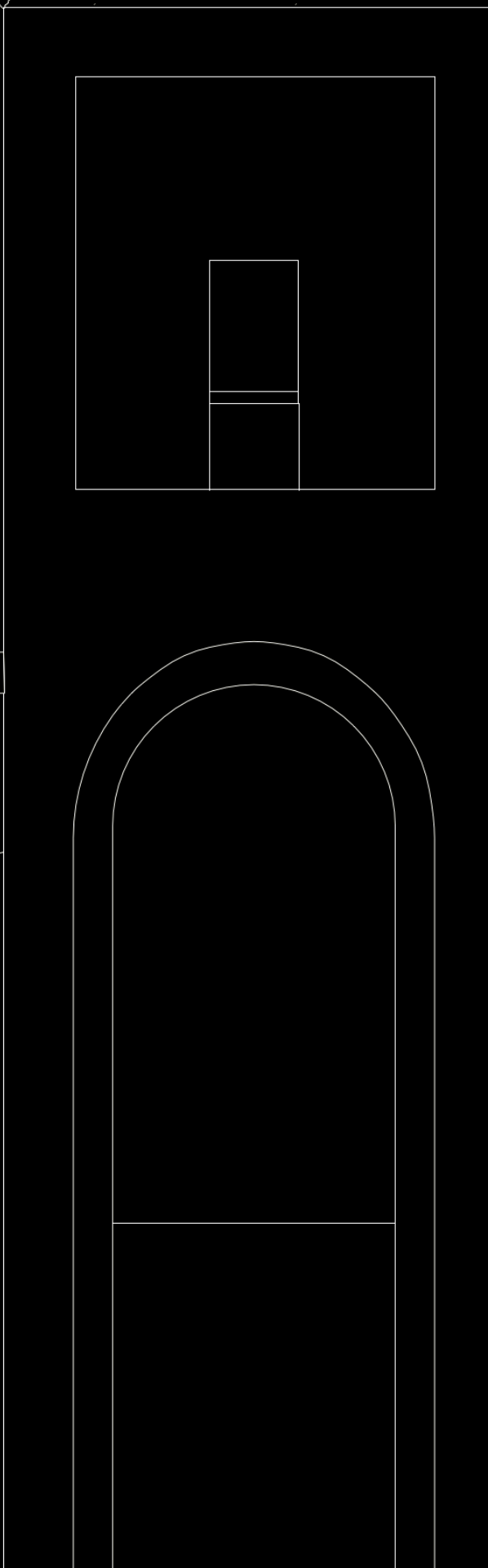
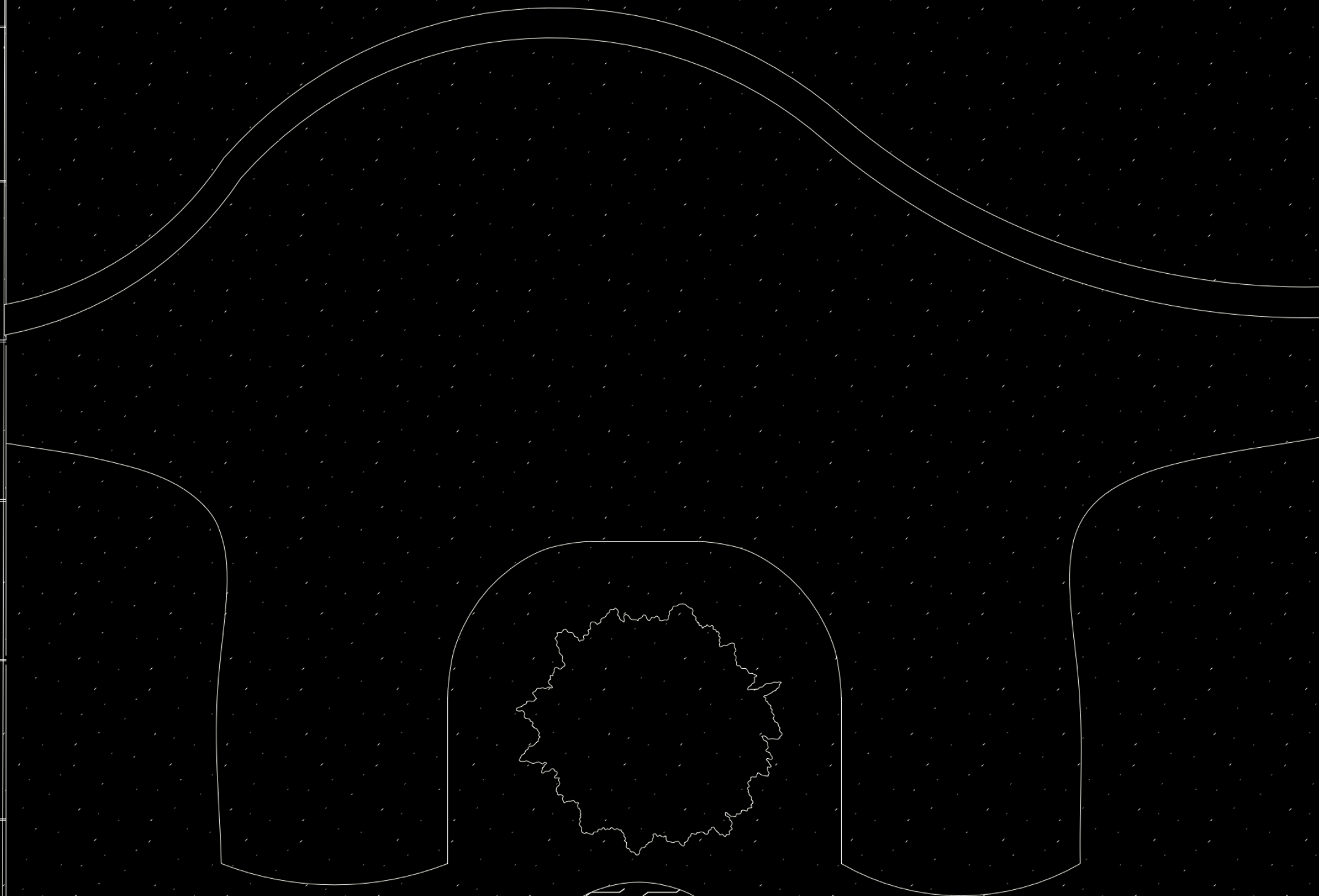

## THE BATHS

The ritual of the care of the feet and hands for young and older generation is at the center of the temple of the care of the body, the baths. These parts of the body are the most important for independent living in the later stage of life. The water complex is a conversion of the old gyms into a space for exterior health, sensuality and exhibitionism connected to the existing pool and gymnasium. Underneath the two wings of the hill, two corridors guide the guests to the entrance of the space. Before entering feet and hands can be washed in ground basins. Changing rooms and showers with retractile dividers offer a fluid use of these intimate spaces with a view through the half moon mirror glazed window. At the center a tepid square with circular pools and ceramic basins surrounded by merdacotta perimeter seating promote conviviality while the rituals take place. On the left wing of the building wooden beds surrounded by opaque white

curtains offer views on the animals in the Stables while body massages happen. The right wing is a transition space where people rest, gossip and rehydrate at the refreshment bar with fresh juices from the Gardens. From the semicircular extension pool a new lift takes the guests to the outdoor deck where a running circuit and a soft red cladding dedicated to yoga and free body activities deploy along the whole length of the roof.

## HIGH FARMS

The rooftops of the residences are now farms in the sky. Crops of seasonal vegetables and herbal plants are grown here. Children and grandparents learn here a different cycle of life. The food harvested here is sold during the farmer market hosted in situ on the roof or indoor in the Arena. Or, it is used in the Kitchen Club to feed the community. The weddings are celebrated among fields of eggplants and courgettes.

Those who seek for care after their hands/feet and body gather in the tepid pools of the baths. This is extension and refurbishment of the existing pool and gymnasium. Here young and old take care of their exterior health. The most popular space is the circular feet-care pools. Here the ritual of the younger washing feet to the older takes place.

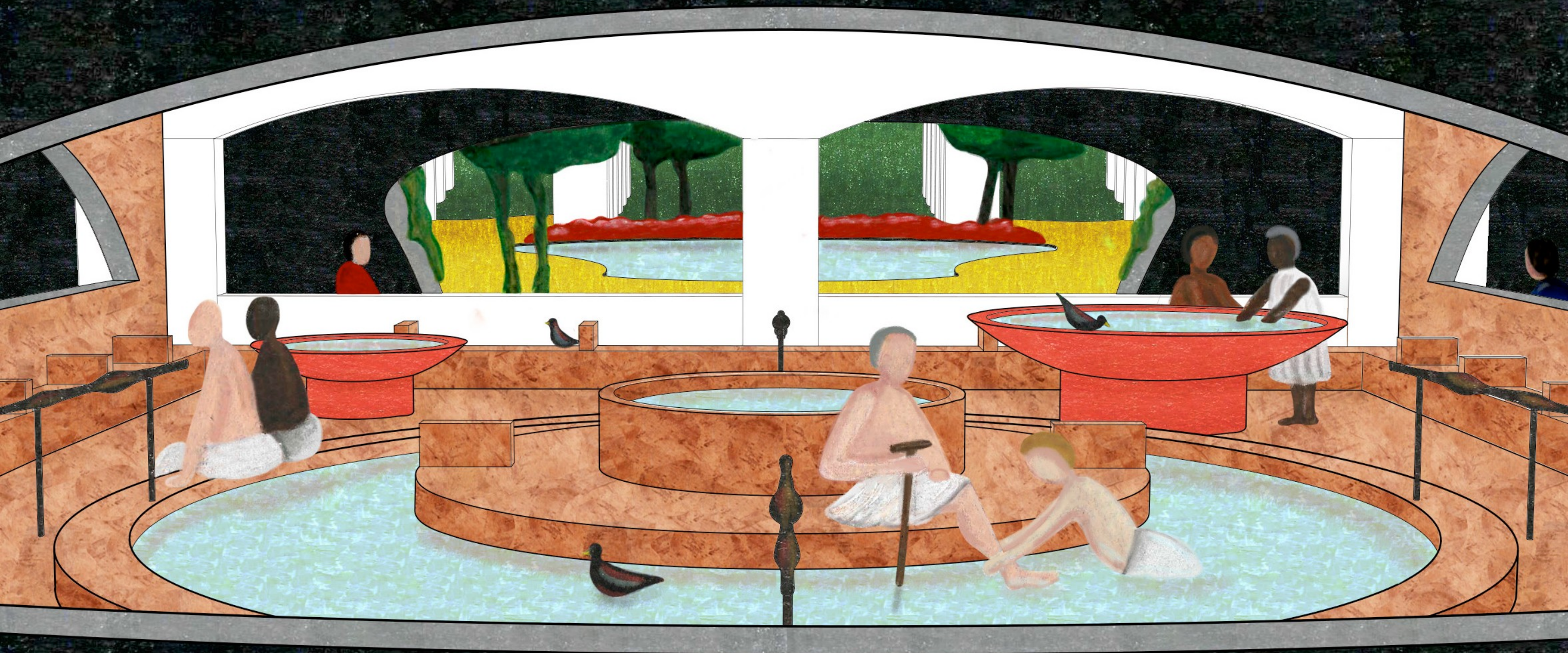

- key
- 1. black matt plaster partition
  - 2. chestnut hand rail
  - 3. made-in-estate merdacotta\* feet-care pools
  - 4. made-in-estate red ceramic basins

- 5. made-in-estate merdacotta\* seamless floor and benches
- 6. restored existing interior facade wall
- 7. black matt plaster ceiling
- 8. recycled aluminium profiles

merdacotta\* terracotta made from animal excrement in the stables and cooked in the workshops kilns

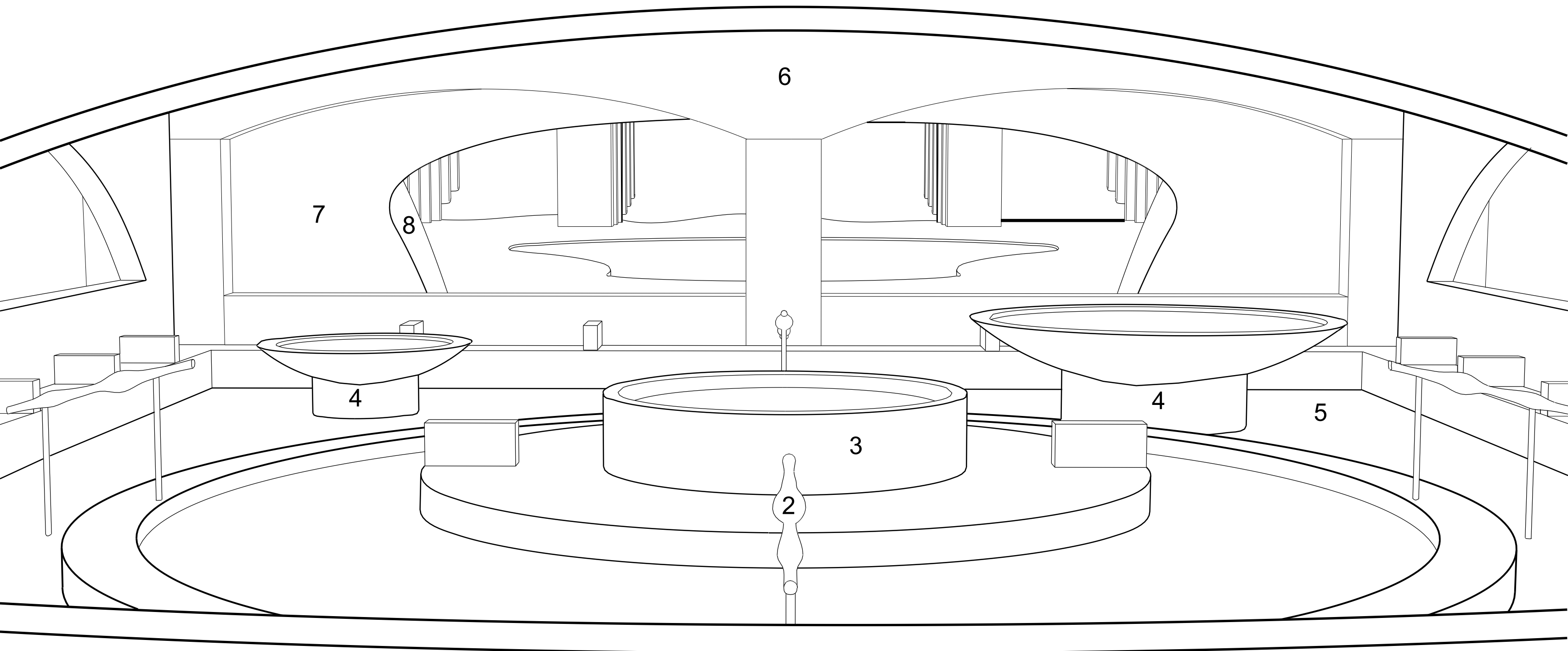

key

- 1. entrances with hand-feet washing basins
- 2. changing rooms with walnut furniture
- 3. shower rooms with chestnut dividers
- 4. feet-care pools
- 5. hand-care adults and children basins
- 6. hand-rails to help elderly entering the pools
- 7. seating with armrest
- 8. body-care hall with adjustable moving wooden beds
- 9. walnut furniture against reflective glass walls looking over stables
- 10. 3d printed biostatistic refreshment bar
- 11. seating beds and rest area looking over the pools
- 12. elevator to rooftop outdoor deck
- 13. pool extension
- 14. existing pool
- 15. portico

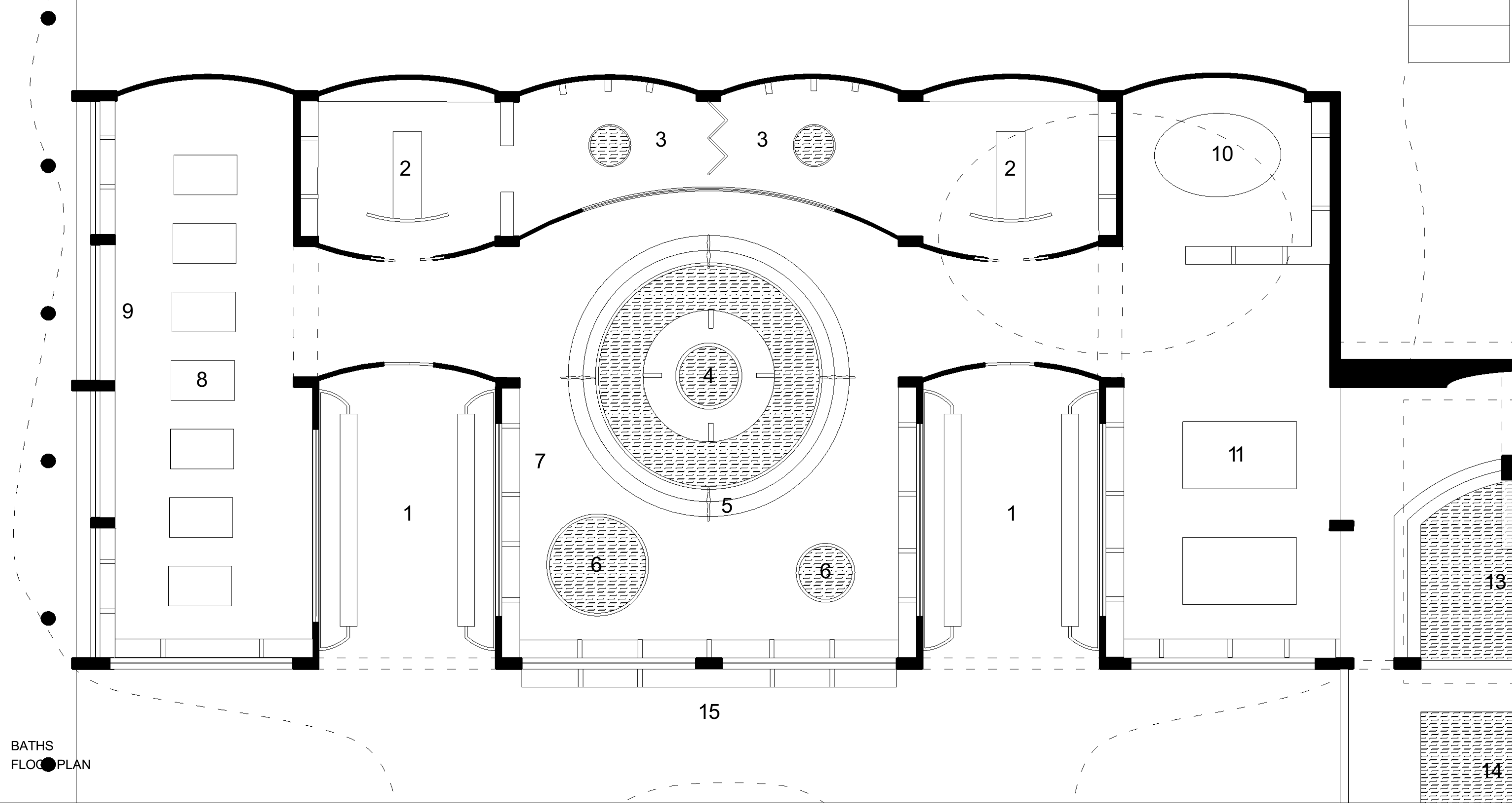

BATHS FLOOR PLAN

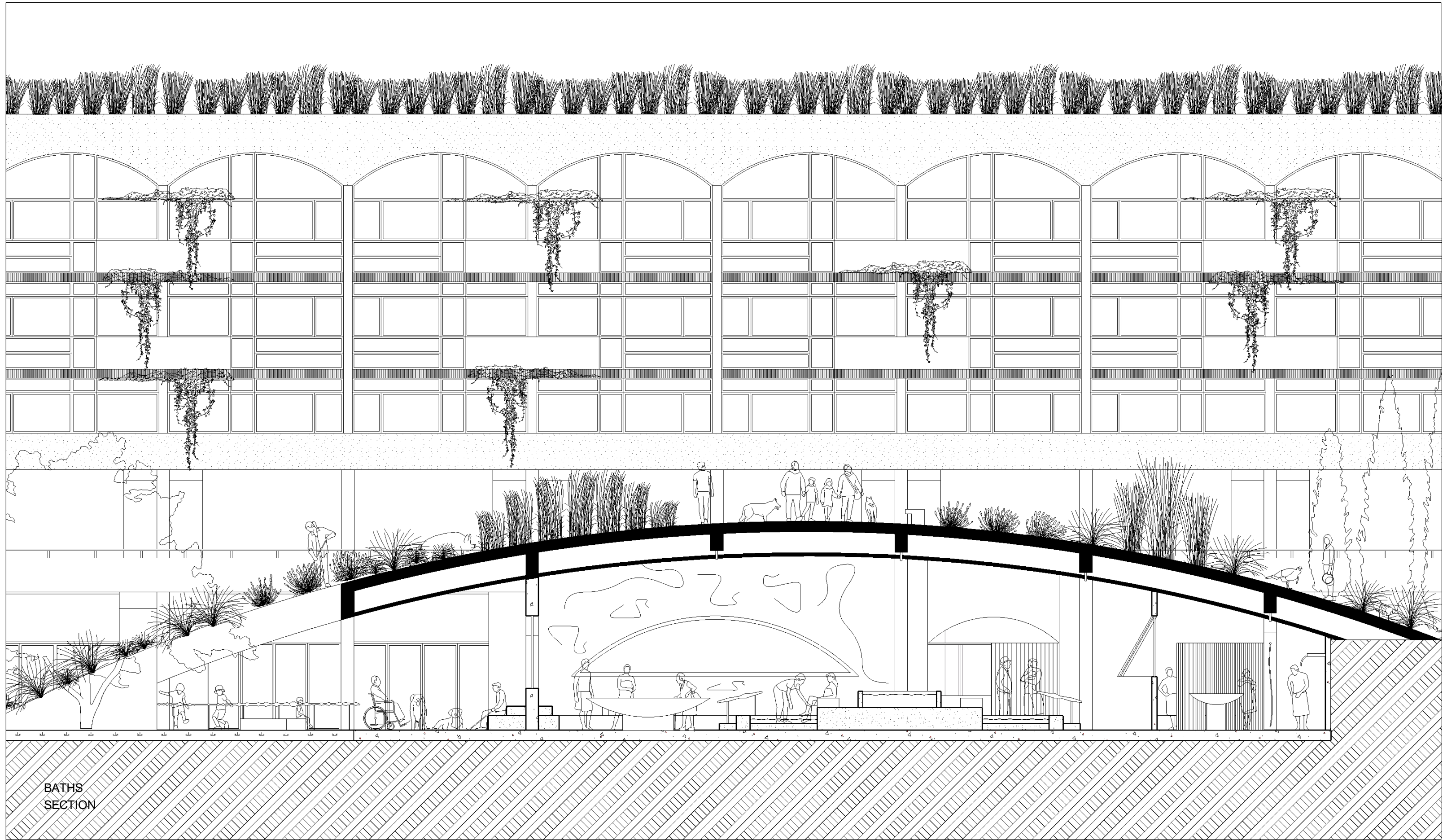

BATHS  
SECTION

# The High Farms

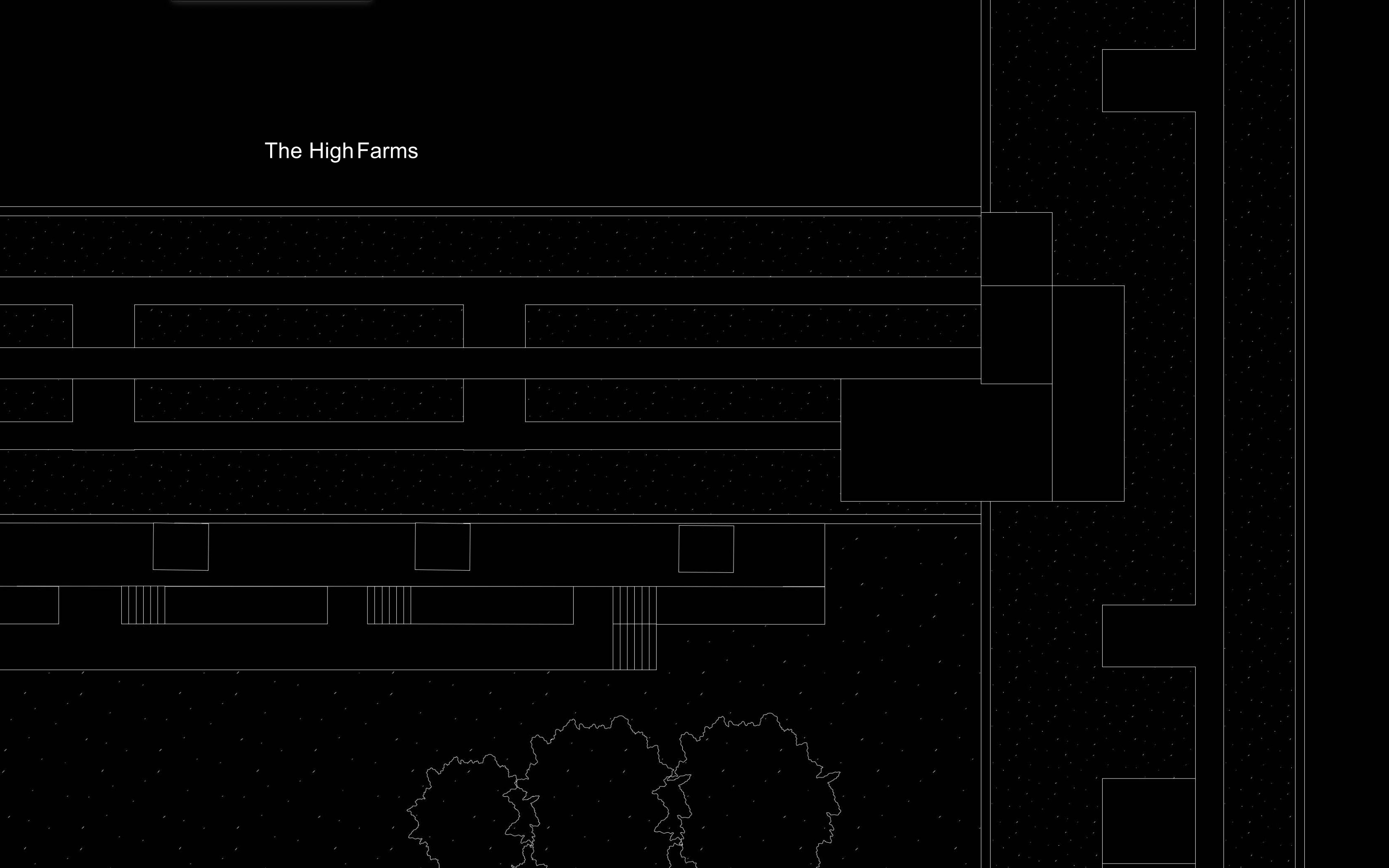

In summer afternoons while the parents are in the workshops, the children and grandparents take care of the crops on the converted roofs of the residences. Here they learn the plants cycles of life. Vegetables are harvested to be used in the kitchen club or sold during the Sunday Market on the roofs or indoor in the arena.



key

- 1. entrance from lift/stairwell
- 2. risen wooden plant bed on maisonettes skylight
- 3. lower plantbed
- 4. gravel pathway
- 5. middle plant bed
- 6. walnut bench with armrest and wheelchair access to risen bed underneath aluminium arch for vines
- 7. chestnut hand-rails
- 8. panorama

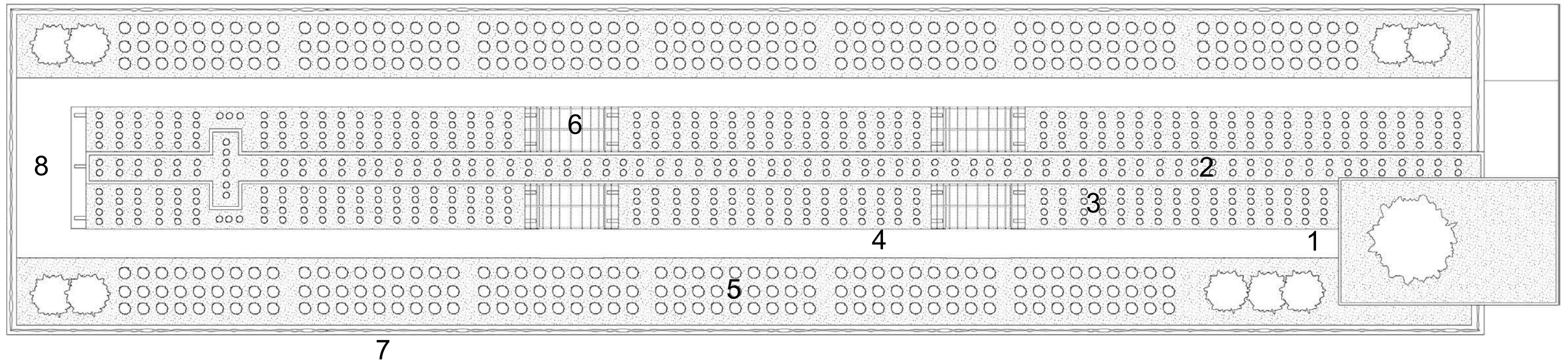
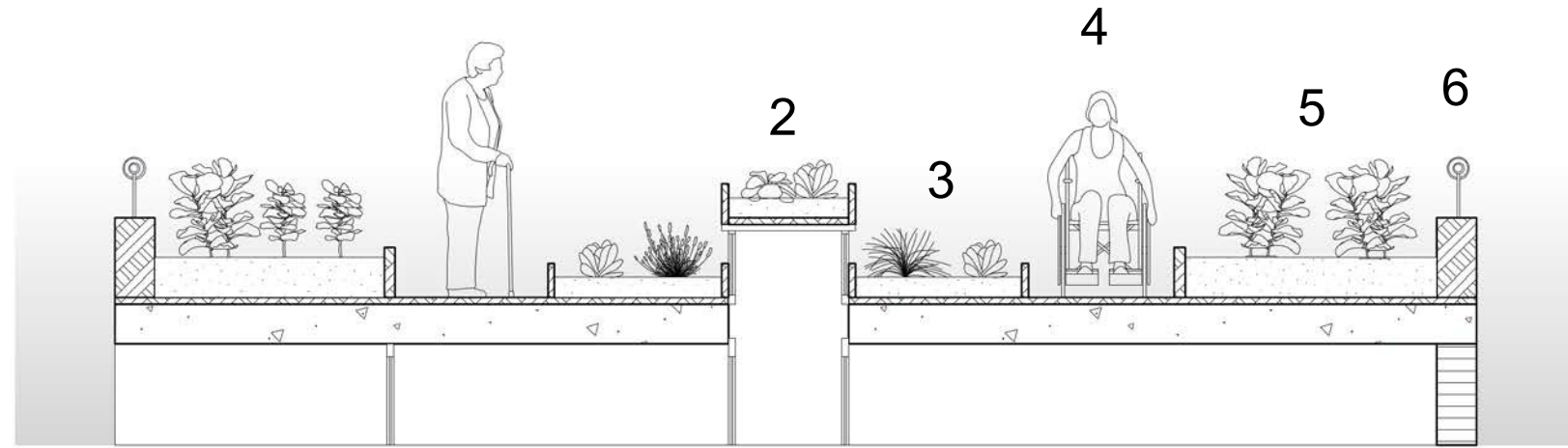

TYPICAL ROOFTOP  
FARM LAYOUT

## The Maisonettes

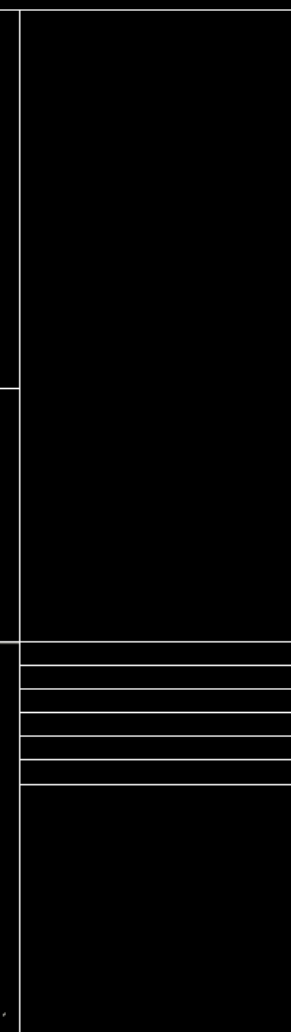

## MAISONETTES

The bigger families live here. The previous residences offer large temporary shared living spaces. Horizontal perforations through walls and satin aluminium foldable devices retract and expand the spaces. The family grow with one, two, three child, having space to have the support of grandparents next door.

## THE ARENA

An underground covered void created to promote amusement, adrenaline and magic between generations. The previously unused garages have been demolished and converted into an indoor pavilion that connect ground and underground levels through a landscaped walkable dome. An opening situated south of the hill welcomes the visitors to the multipurpose performance space. The first glimpse of the void is from the eyes, large ovaloid openings which connect visually the

spaces, are home of an orgy of plants and let light diffuse. The foyer area consists in two narrow spaces. One is a buffer corridor for tickets sale and quick chats while the back is a seated VIP balcony for the seniors. Here is where the most gossiped conversations happen. On the left and right side, the wings. They take down the visitor to the ground level with promenades wrapping around the bright red insulating cladded walls which indicate the way. One is a stairs and the other a ramp. Both are designed to make the visitors stop, chat and observe the scene. Here again a customized organic shaped handrail guide people downstairs. Along the way seating area are created for those who need a rest along the way. Once on the ground floor the central space changes depending on the event happening. Usually, a monolith of steps fill the void like a boat docked at the pier. The steps are wide and shallow to promote small groups of young and older people with picnics, rugs, cocktails and shishas. In



It's dinner time of a summer night. Grandparents and children of the connected households reunite around the foldable chestnut table in the shared living rooms on the ground floor. The younger family members cook with mom while they older one are served.

key

- 1. matt plaster perforated wall
- 2. satin recycled aluminium foldable partition
- 3. chestnut join tables on wheels
- 4. walnut benches with backrest insertion
- 5. velvet chairs
- 6. existing polished tiled floor
- 7. customized chestnut handrail
- 8. glass smart homeinterface

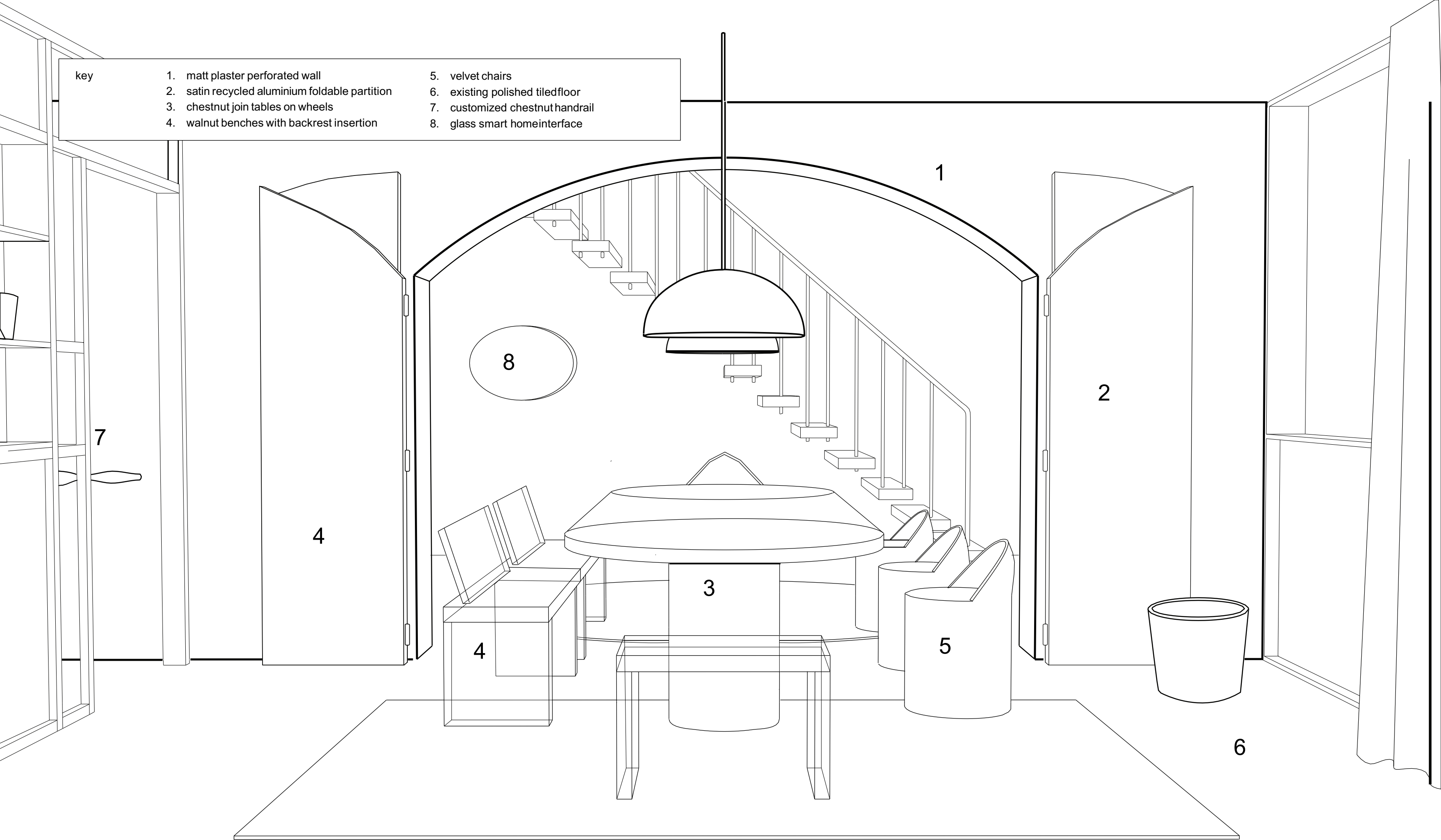

key

1. temporary perforated wall to expand the domestic space
2. foldable screens for privacy.
3. shared living rooms with independent kitchens.
4. private grandparents bedroom with bathroom.
5. independent balconies.
6. friendship chestnut benches on shared balconies to promote independent and community growth.
7. private family bedrooms.
8. private family studio overlooking grandparents living room.

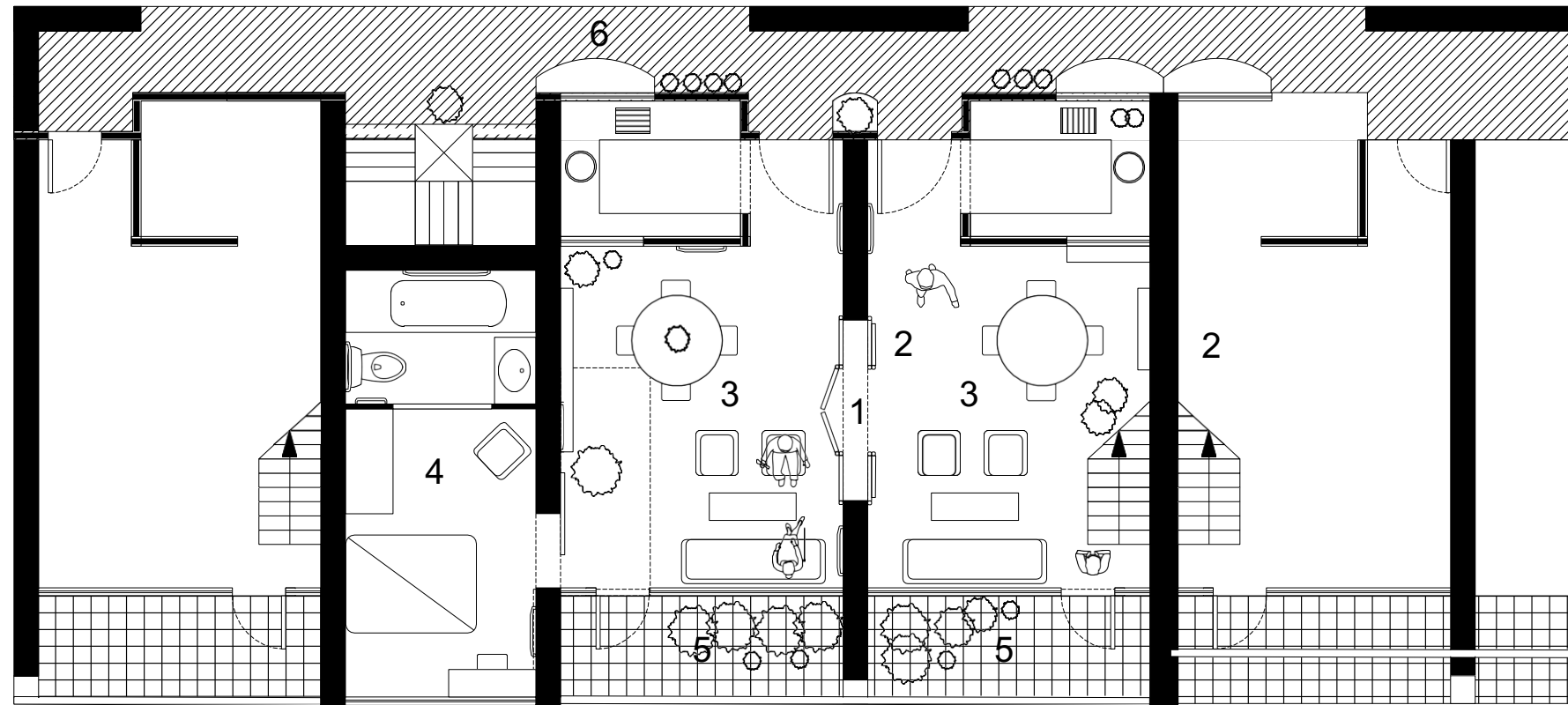

LOWER FLOOR

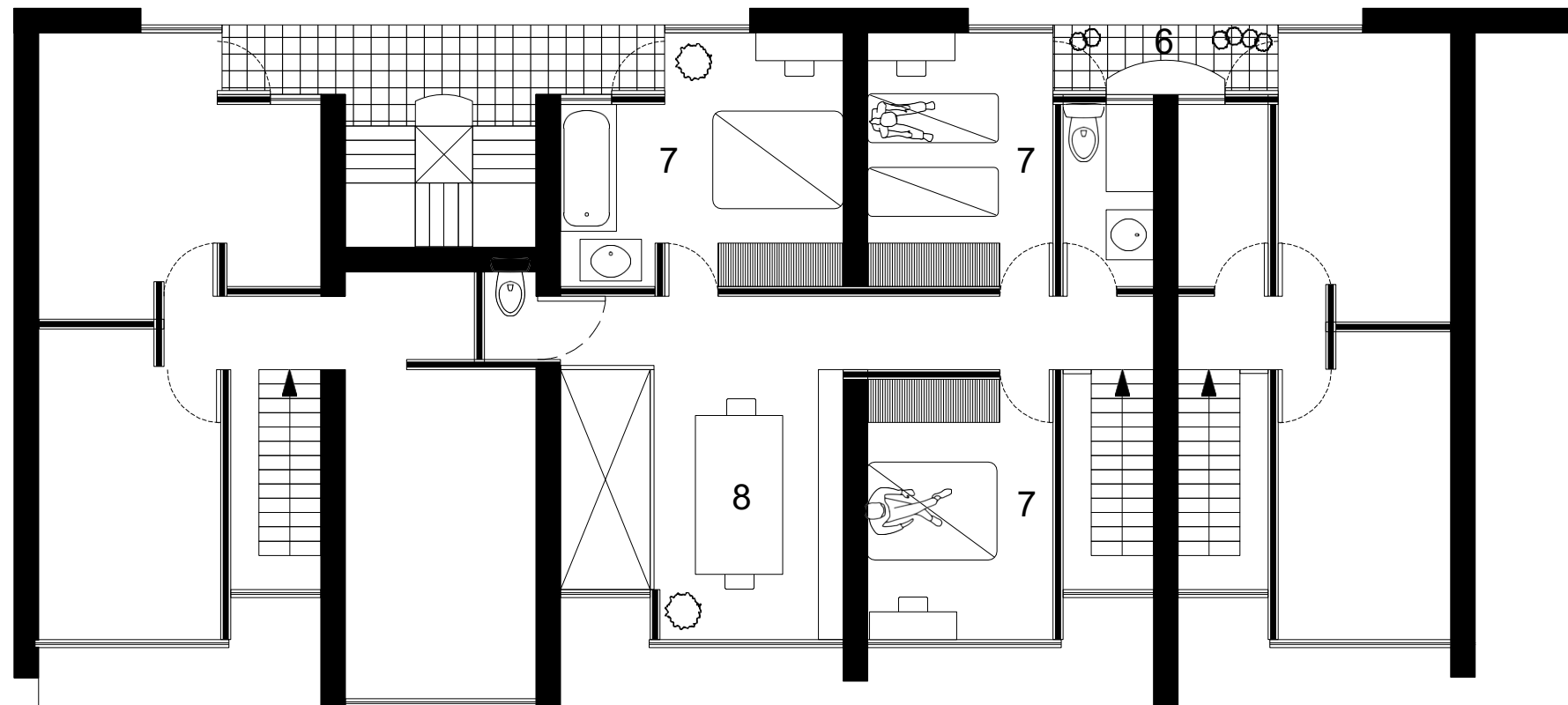

UPPER FLOOR

TYPICAL MERGED  
MAISONNETTE LAYOUT

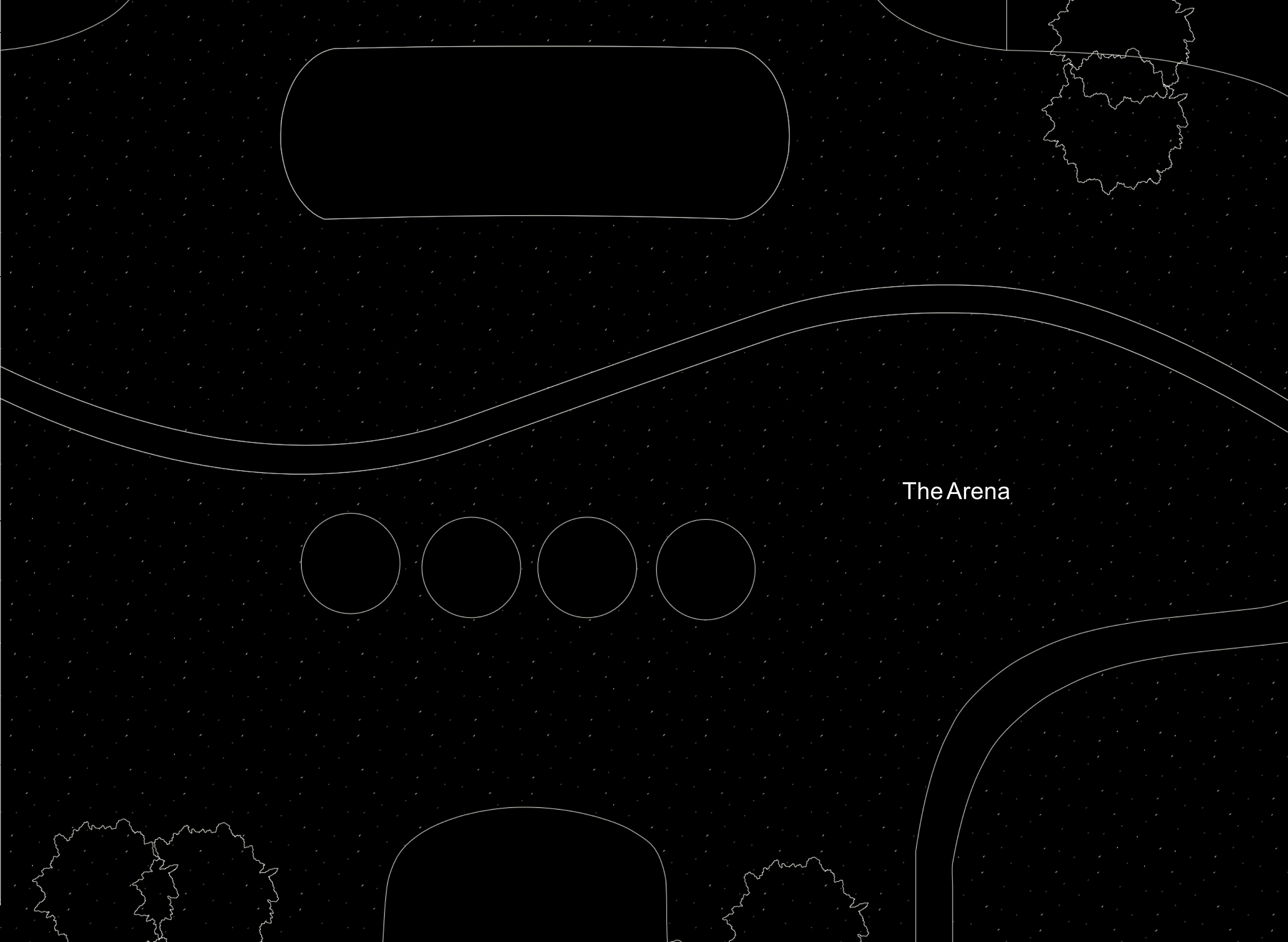
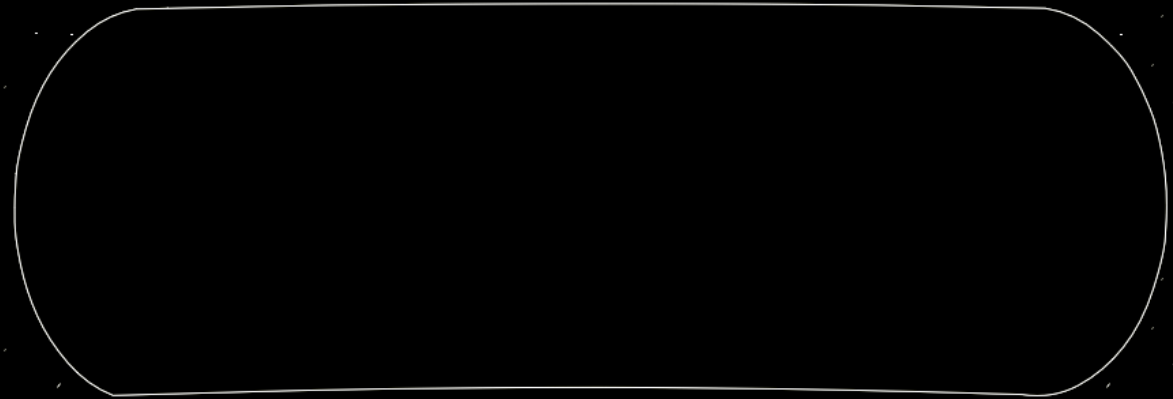
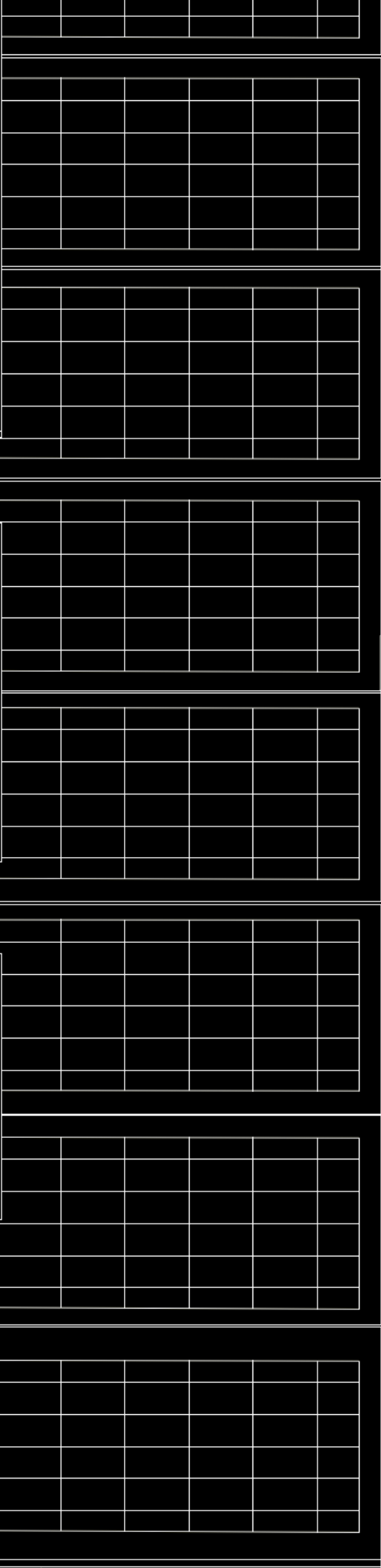

The Arena

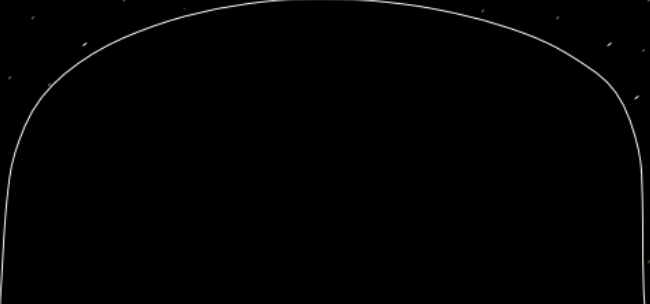

front of the steps, the stage. The ceiling is an indoor sky recreating dusks and dawns and starred summer nights. On the north side a giant movable opening on the roof let the residents become performers on their balconies creating a stronger connection with the Estate community. Sometimes, the arena central space is without steps, a large void filled instead with people. Only a spinning DJ deck in the middle. Shirtless bodies are moving to the rhythm of the music with feathers, diamonds, fire and leather. The space is filled with a mist smelling like summer fields after the rain. Thick light beams move through the arena slowly illuminating the ravers. Other times, the steps are rearranged in crossed, parallel, pyramid, diamond shapes for catwalks, operas, concerts, ballet, plays and important . Around the main square, behind the eyes, a L shape series of smaller rooms host small entertainment spaces, a refreshment bar, rehearsal studios and services. From here two main axes take the visitor to the gardens, stables and workshops.

## THE TEMPLE OF RESONANCE

A circular space wrapped by a spiral ramp take pilgrims on the two levels of the most personal, intimate, and spiritual space of the Estate. A temple of nature, light and souls. A sanctuary to collectively recharge, regenerate and create positive energy for each self and the community at large. Built on the previous cone bastion, the green dome is home of families of birds. In the upper chamber, a water hole collect the rain water. Around it rabbits and pets share moments of resonance with the humans sitting or laying on the ground. Underground, a dark chamber divided into thick curtain cloves is dominated by a endless hole into the ground. Here intermittent light comes at different times of the day and the pilgrims come to meditate to it. Sound bathing seminars are held here by the oldest generations. Spiritual guides for the new ones take care of the place and adjacent Medicinal Gardens.

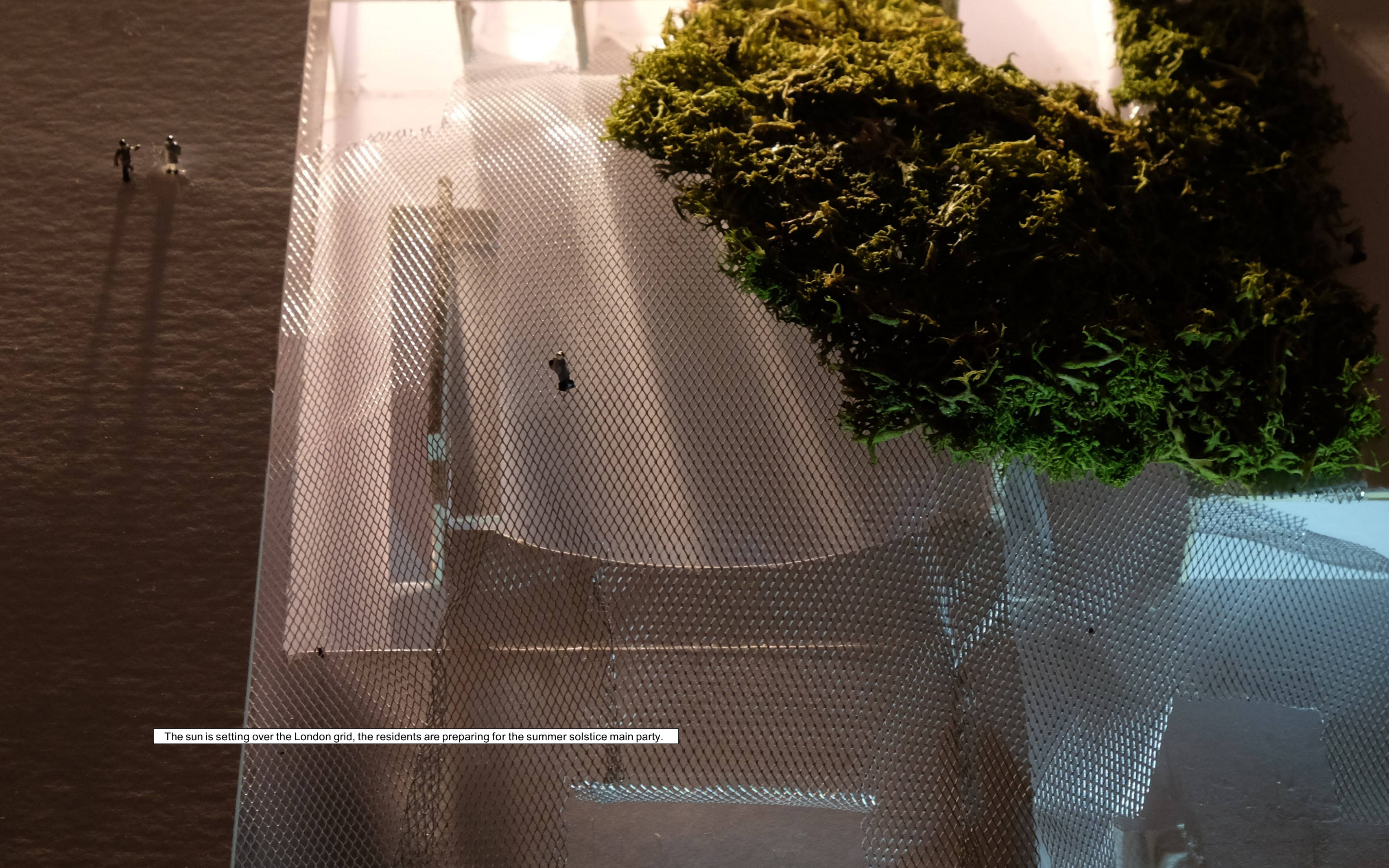

The sun is setting over the London grid, the residents are preparing for the summer solstice main party.

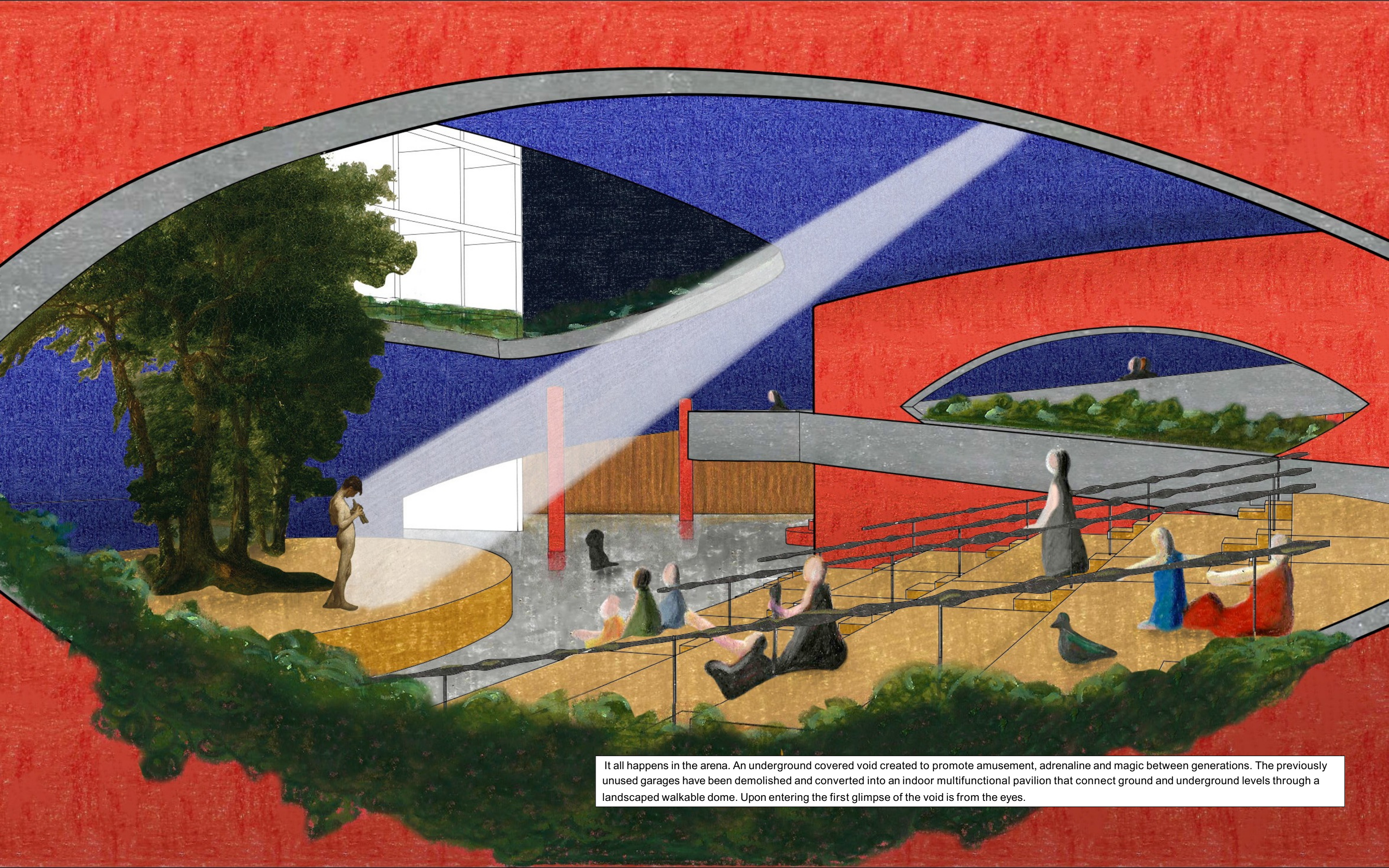

It all happens in the arena. An underground covered void created to promote amusement, adrenaline and magic between generations. The previously unused garages have been demolished and converted into an indoor multifunctional pavilion that connect ground and underground levels through a landscaped walkable dome. Upon entering the first glimpse of the void is from the eyes.

key

- 1. mat red acoustic panels cladded pillars
- 2. modular acoustic descending panels
- 3. satin recycled aluminium balconies with timber ramps and stairs

- 4. Existing polished concrete pavement
- 5. Modular movable timber stage
- 6. modular movable timber steps
- 7. chestnut handrails

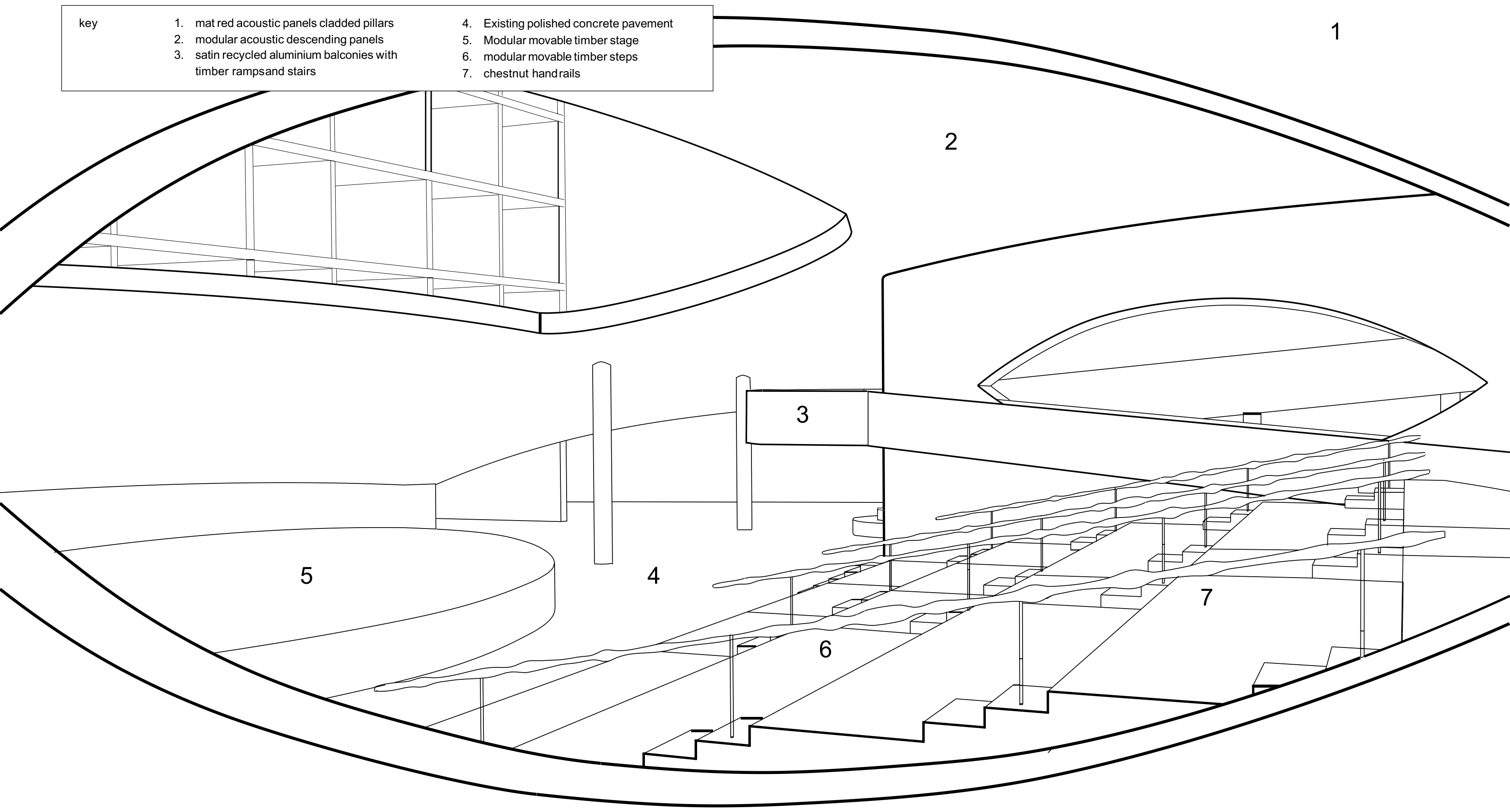

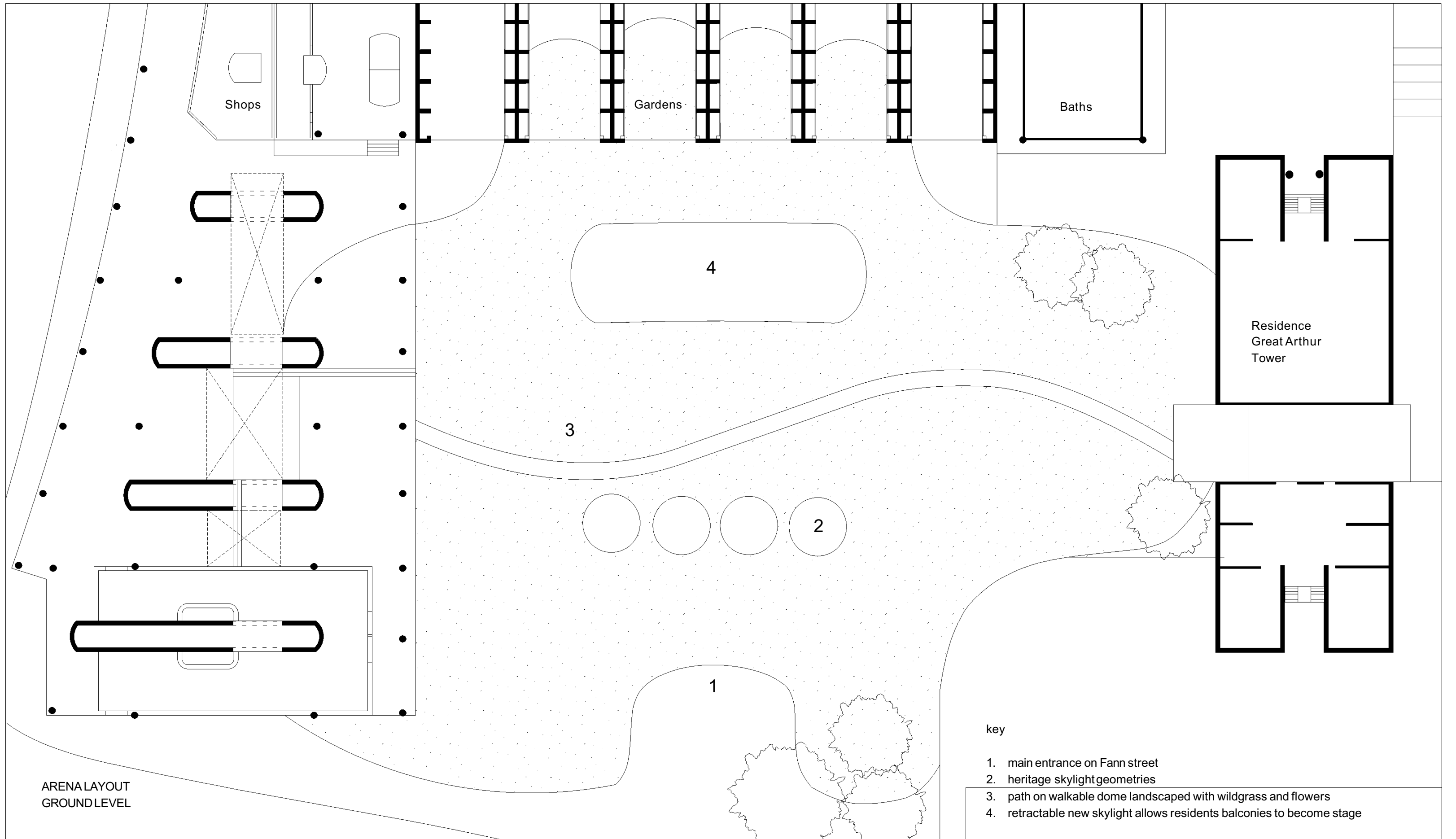

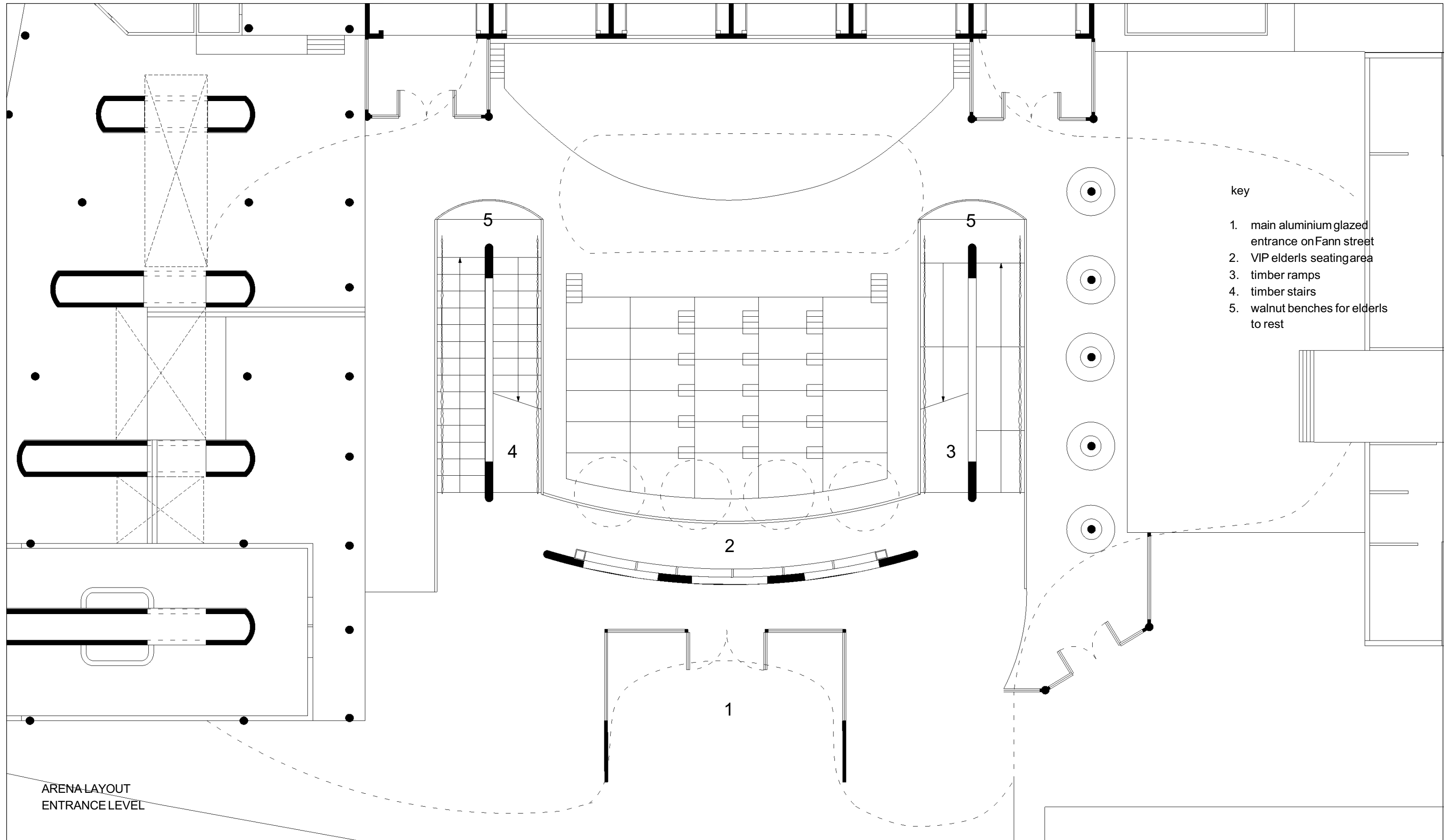

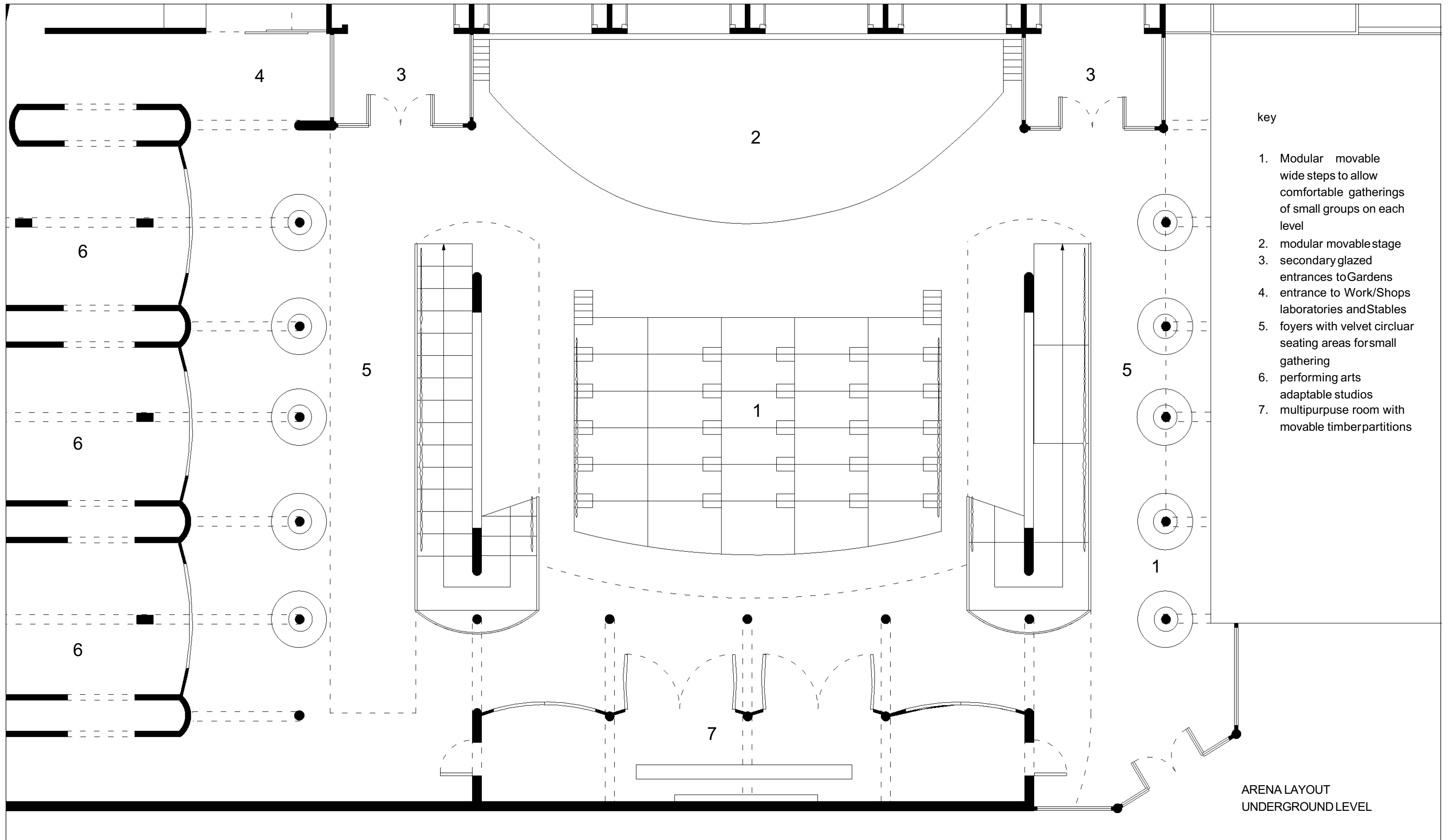

The eyes are large ovaloid opening that connect visually the spaces, are home of an orgy of plants and let light diffuse.  
The central chestnut steps can be rearranged in crossed, parallel, pyramid, diamond shapes for catwalks, operas, concerts, ballet, plays, and conferences.

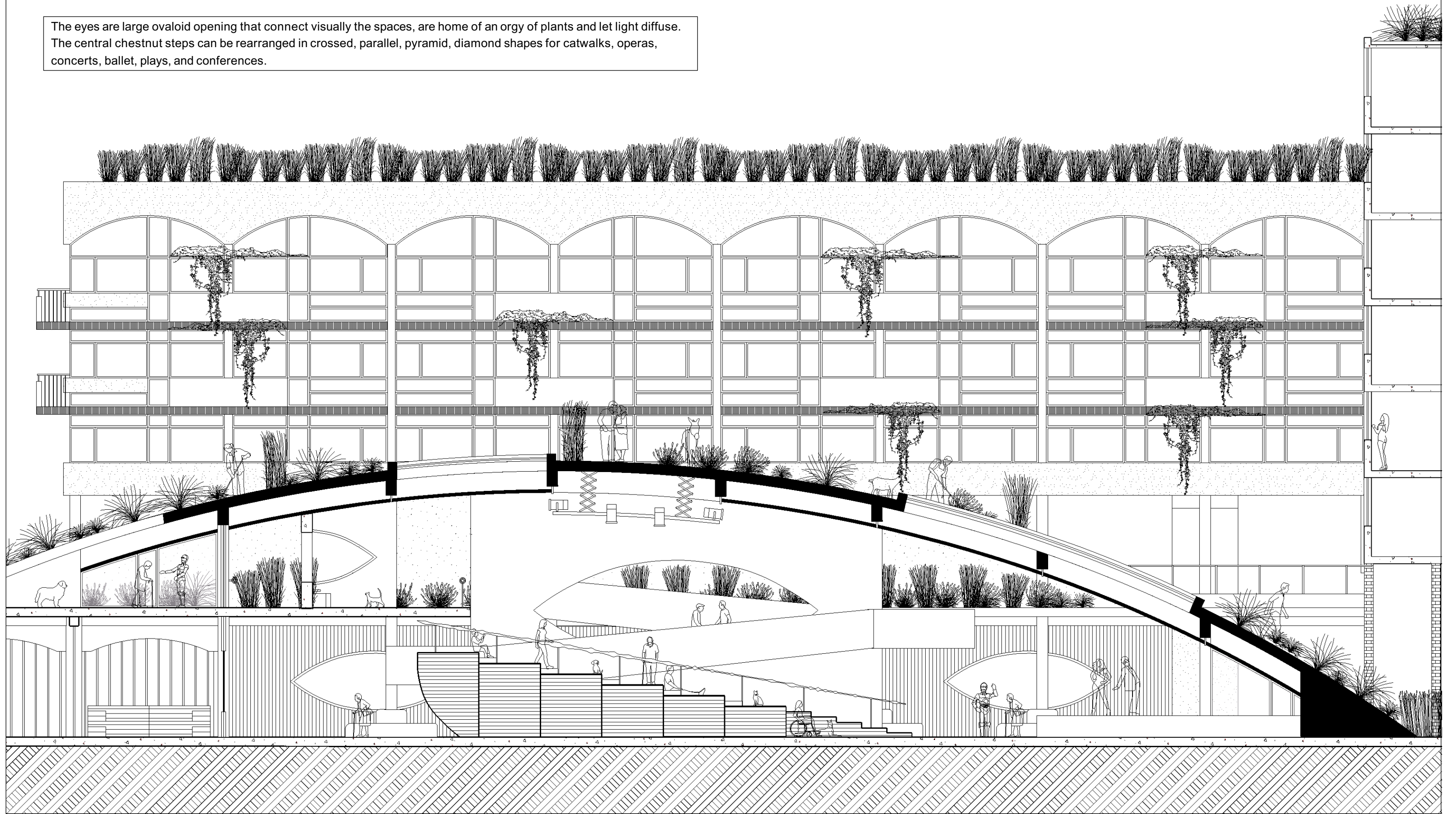

The eyes are large ovaloid opening that connect visually the spaces, are home of an orgy of plants and let light diffuse.  
The central chestnut steps can be rearranged in crossed, parallel, pyramid, diamond shapes for catwalks, operas, concerts, ballet, plays, and conferences.

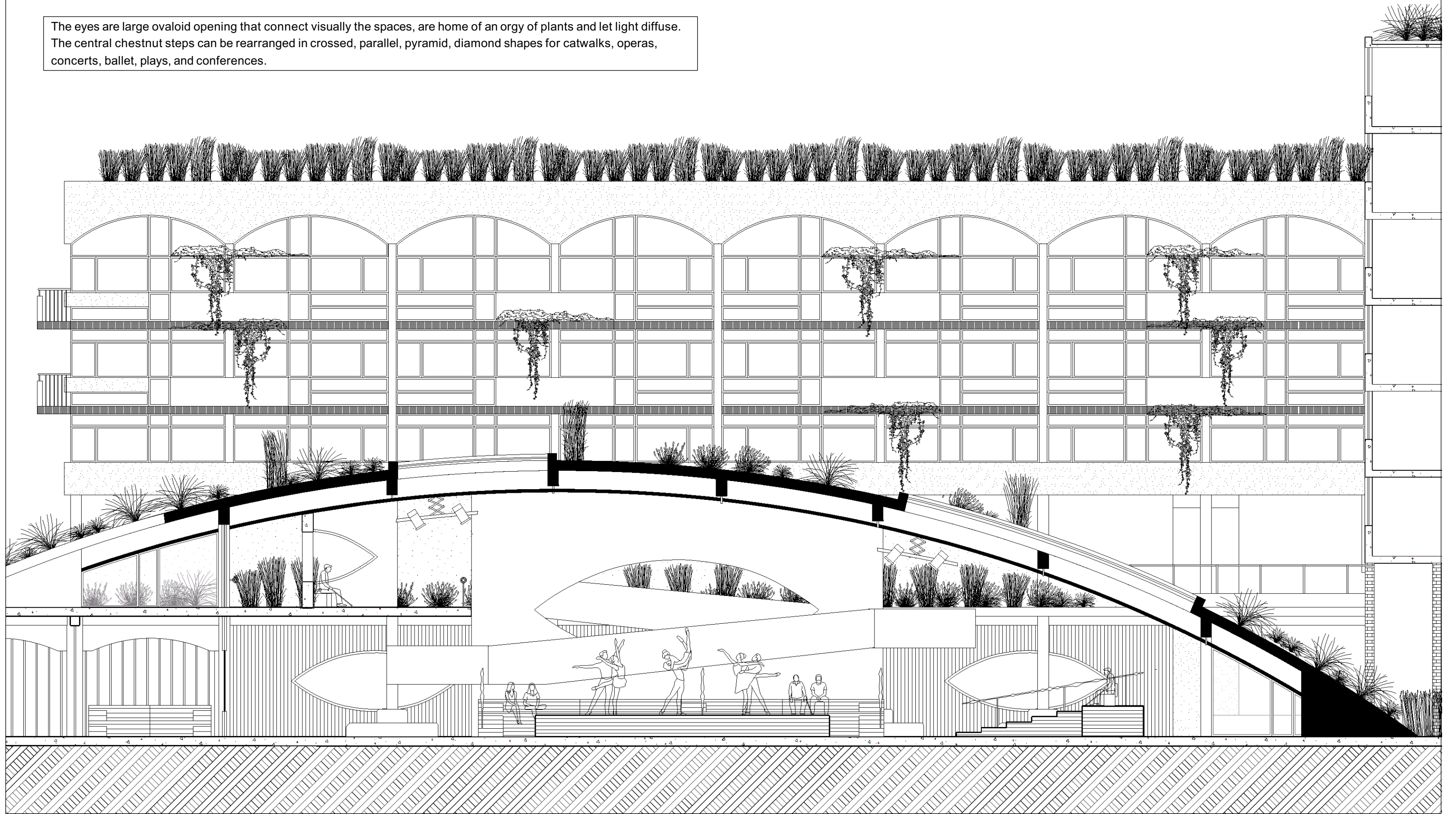

The eyes are large ovaloid opening that connect visually the spaces, are home of an orgy of plants and let light diffuse.  
The central chestnut steps can be rearranged in crossed, parallel, pyramid, diamond shapes for catwalks, operas, concerts, ballet, plays, and conferences.

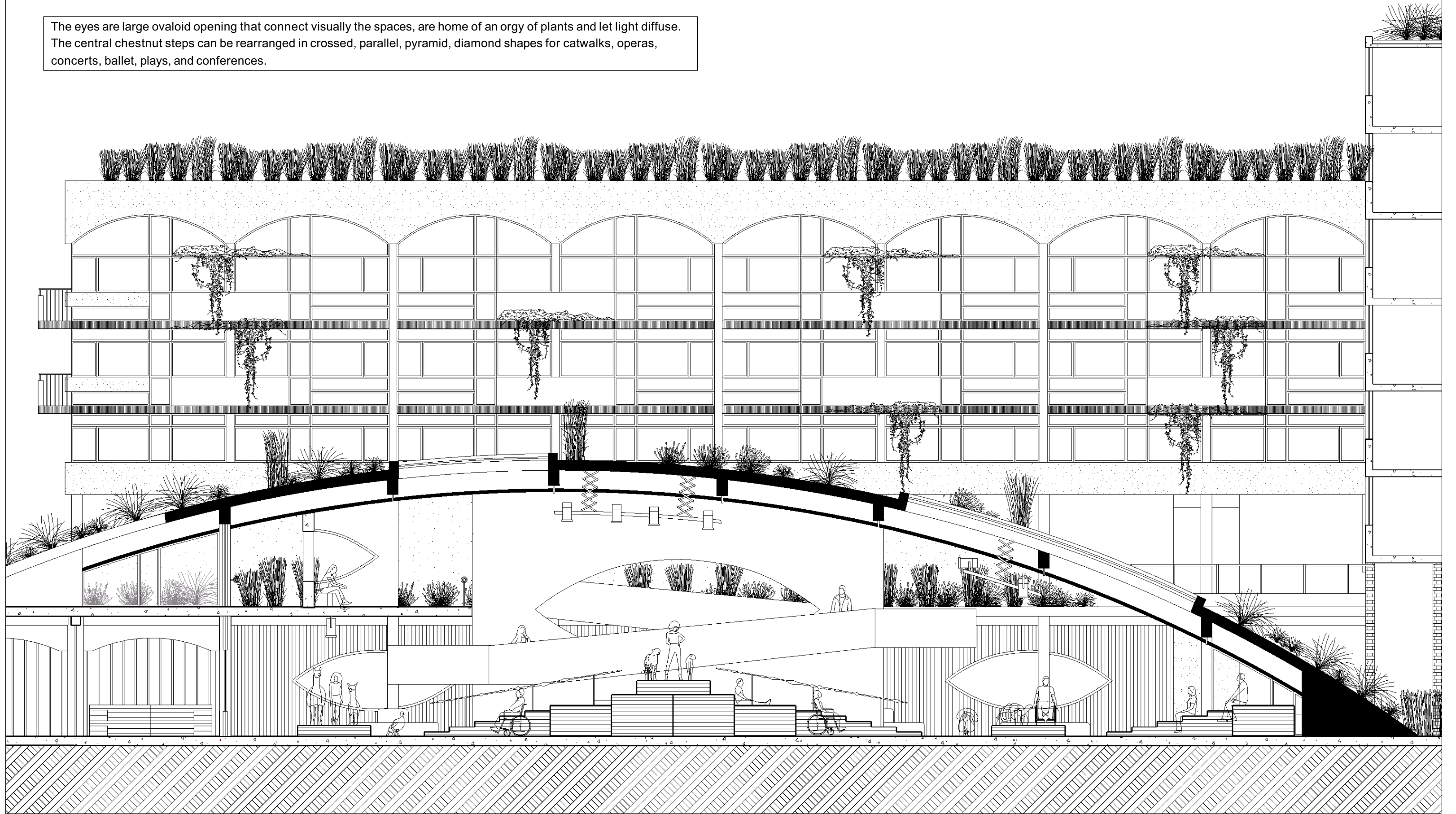

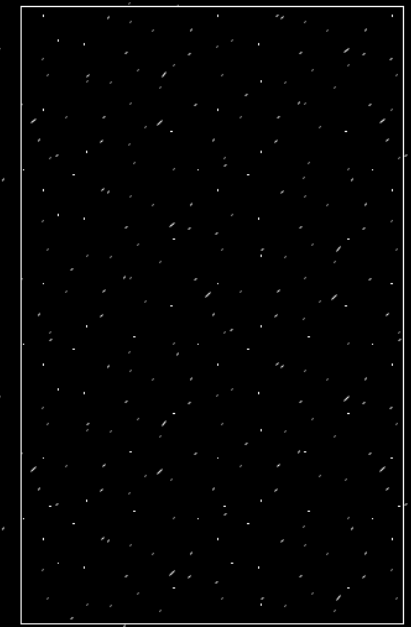
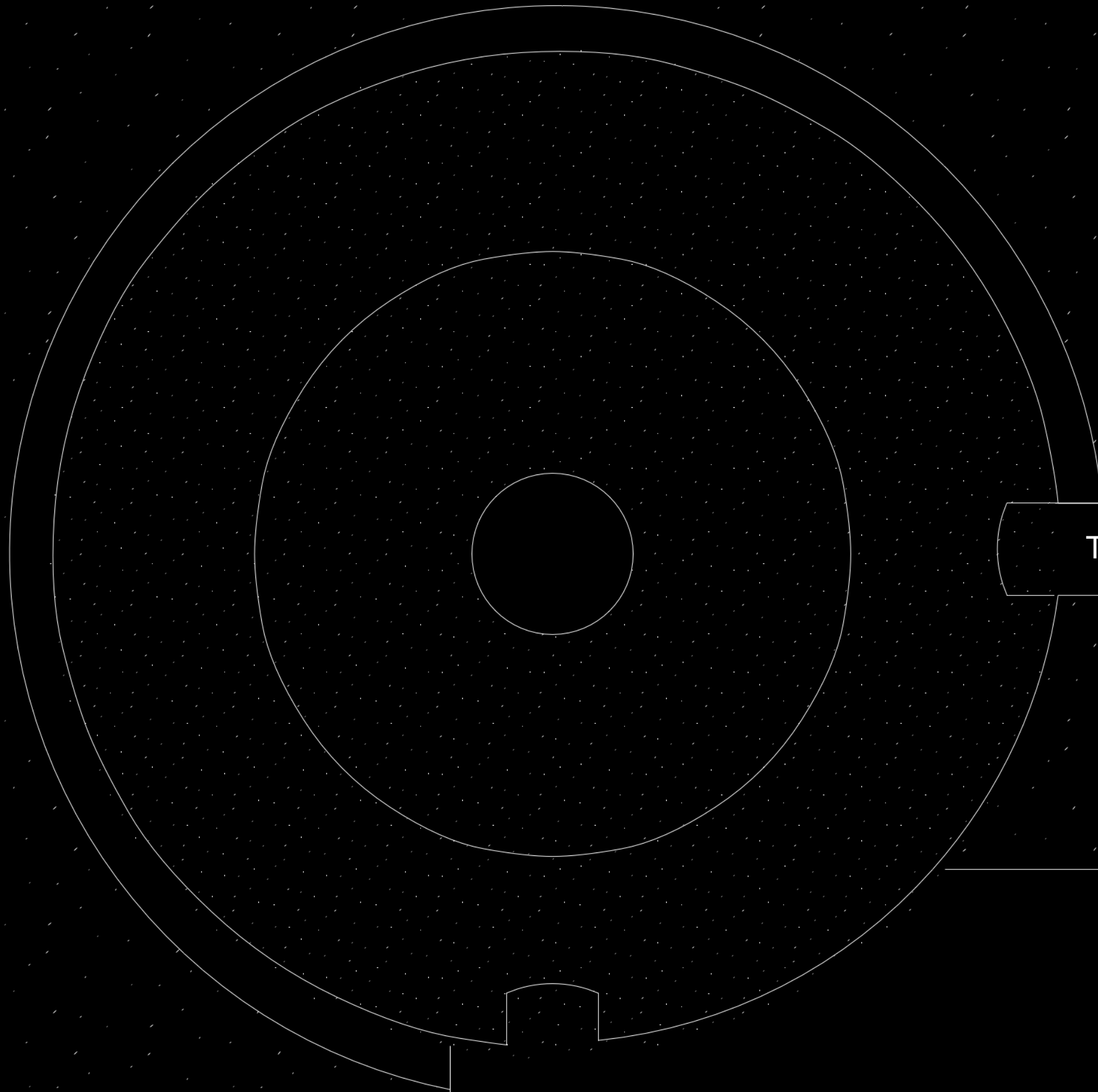
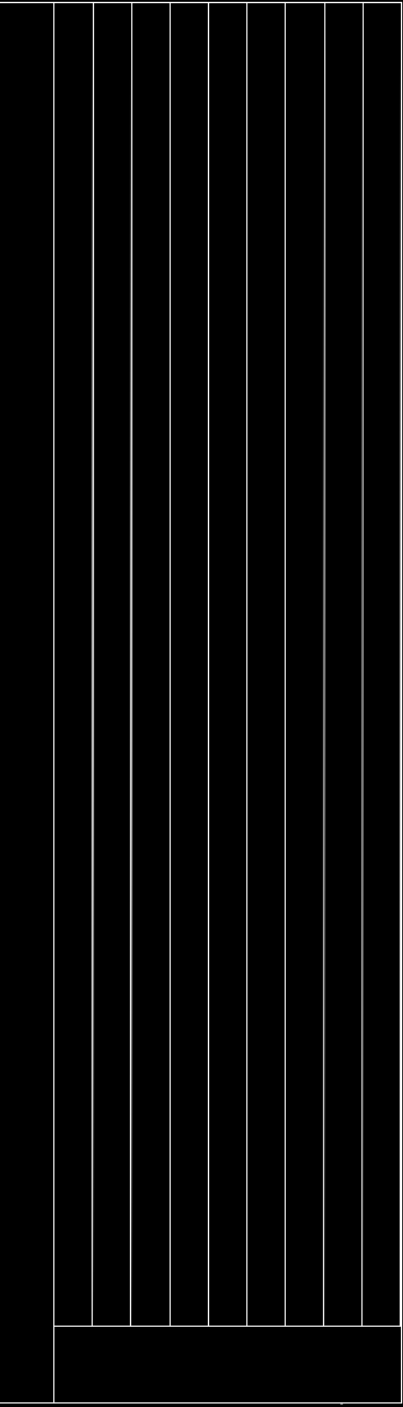

Temple of Resonance





It is night. It is day. In the early morning, the residents come to the peaceful place, where bird trees and animal coexist under one green permeable roof. The temple is a place for silence, pray and meditation. The circular internal ramp takes the pilgrims from the medicinal gardens to the main halls. The hand rail of life guides young and old to the sublime.

- key
- |                                  |                       |
|----------------------------------|-----------------------|
| 1. aluminium net andivy          | 4. existing structure |
| 2. aluminium dome beam structure | 5. gravel spiral path |
| 3. chestnut customized handrail  |                       |

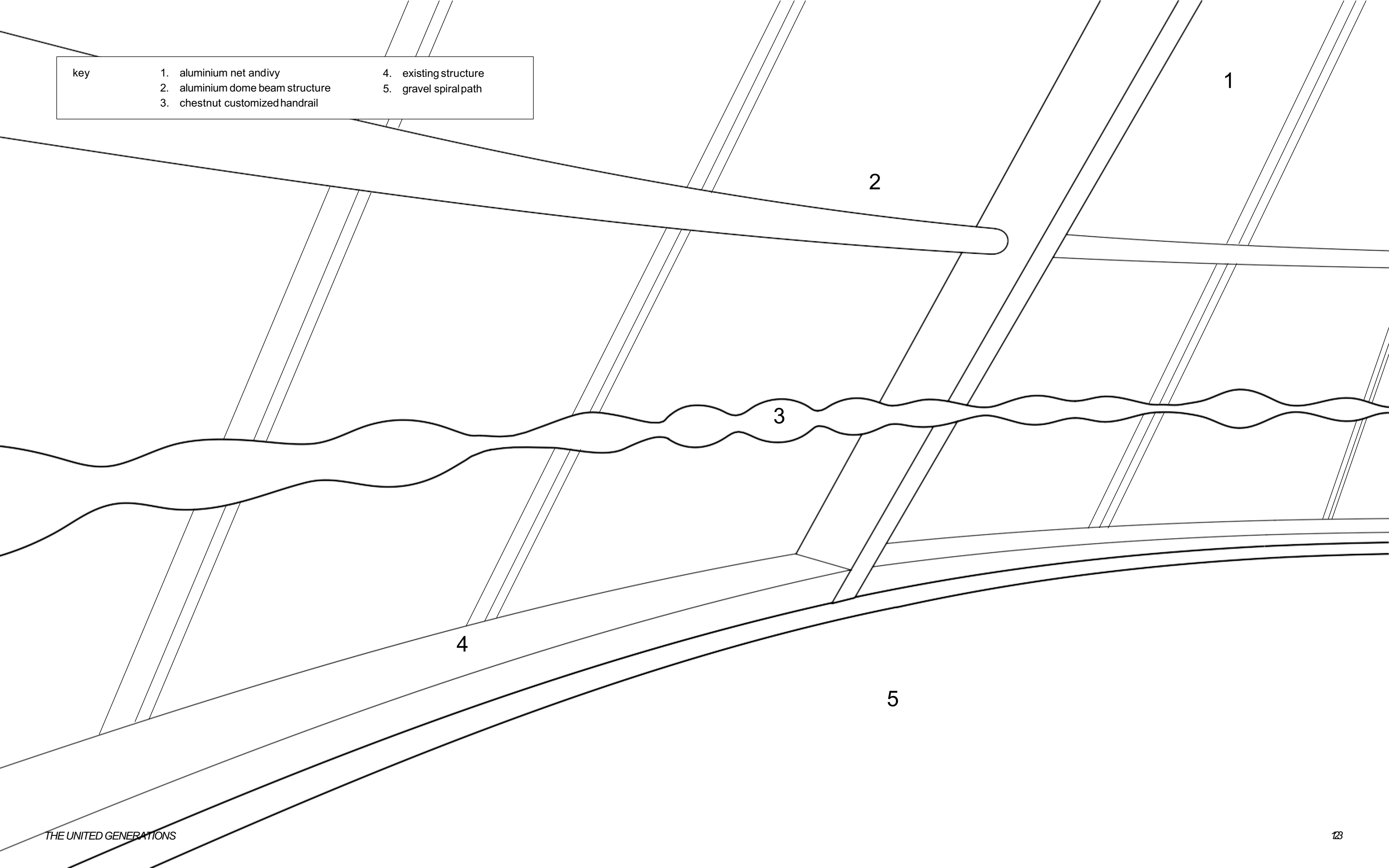

TEMPLE SECTION

- key
- 1. Medicinal garden entrance
  - 2. circular ramp from Medicinal Gardens to main chamber
  - 3. underground meditative chamber with iridescent light circular hole
  - 4. main chamber with water hole, perimeter bench and animalground
  - 5. aviary interior with open air oculus
  - 6. Water tanks to connect inside/outside of the temple.

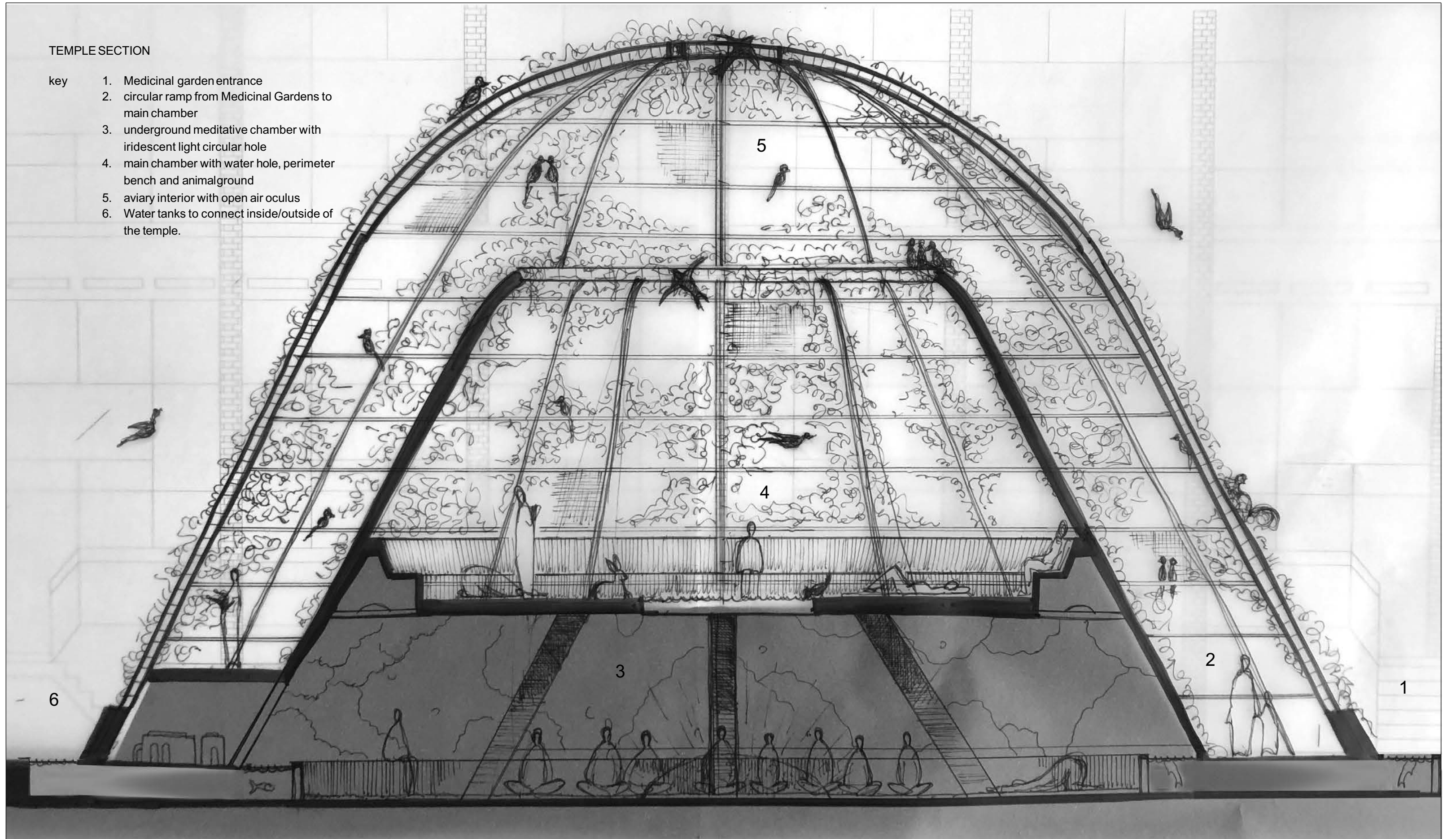

In Arcadia, time loses its perception. There is no new nor old, just the present.



We all want to help one another,  
human beings are like that.

Let us fight for a a decent world that will  
give youth a future and old age security.

C.C. (1940)

## THANKS TO

Jenny Jones (Studio Jenny Jones)  
Barry Curtis (Central San Martins)  
Rebecca Mckillip (Dalzien & Pow)  
Brendan Commane (Helen Hamlyn center)  
Lucy Gallwey (Royal College of Art)  
Graeme Brooker (Royal College of Art)  
Vicky Richardson (Royal College of Art)  
Jeremy Myerson (Helen Hamlyn center)  
Sarah Goodall (Katherine Low Settlement)  
Dawn Killen (Katherine Low Settlement)  
Sarah Rackman (Katherine Low Settlement)  
Cam Jarvis (Company Drinks)  
Hannah Lambert (Royal College of Art)  
Howard Sullivan (Yourstudio)  
Reiko Yamazaki (Royal College of Art)  
Ian Hunter (Material Council)  
Manja Van De Worp (Royal College of Art)  
Jo-Anne Bichard (Helen Hamlyn center)

Maria Rosa Albertini

Elvio Lonardi

Matteo Faccioli

Diego Flauzino

Pietro Grandi

Michele Molon