

S P E C T A C L E



Thesis Design Project

Royal College of Art, School of Architecture,
MA Interior Design

Tutor: Ian Higgins

2021-2022





An Optical Store: Cubitts

'Cubitts' is an independent British company based in Kings Cross, London, that offers ready-made, fitted, and bespoke spectacle frames with carefully designed details.

Engineered for your eyes, they marry traditional manufacturing methods with contemporary technologies to create modern spectacles.

The structural rivet designed and used by Lewis Cubitt in his development of the granary has inspired the form of the signature hinges used by Cubitts the spectacle makers and this, in turn, has informed the brand's logo.

Driven from these ideas, the design scheme is formed through a mixture of traditional crafted and digital engineered elements reflecting the client's making process.

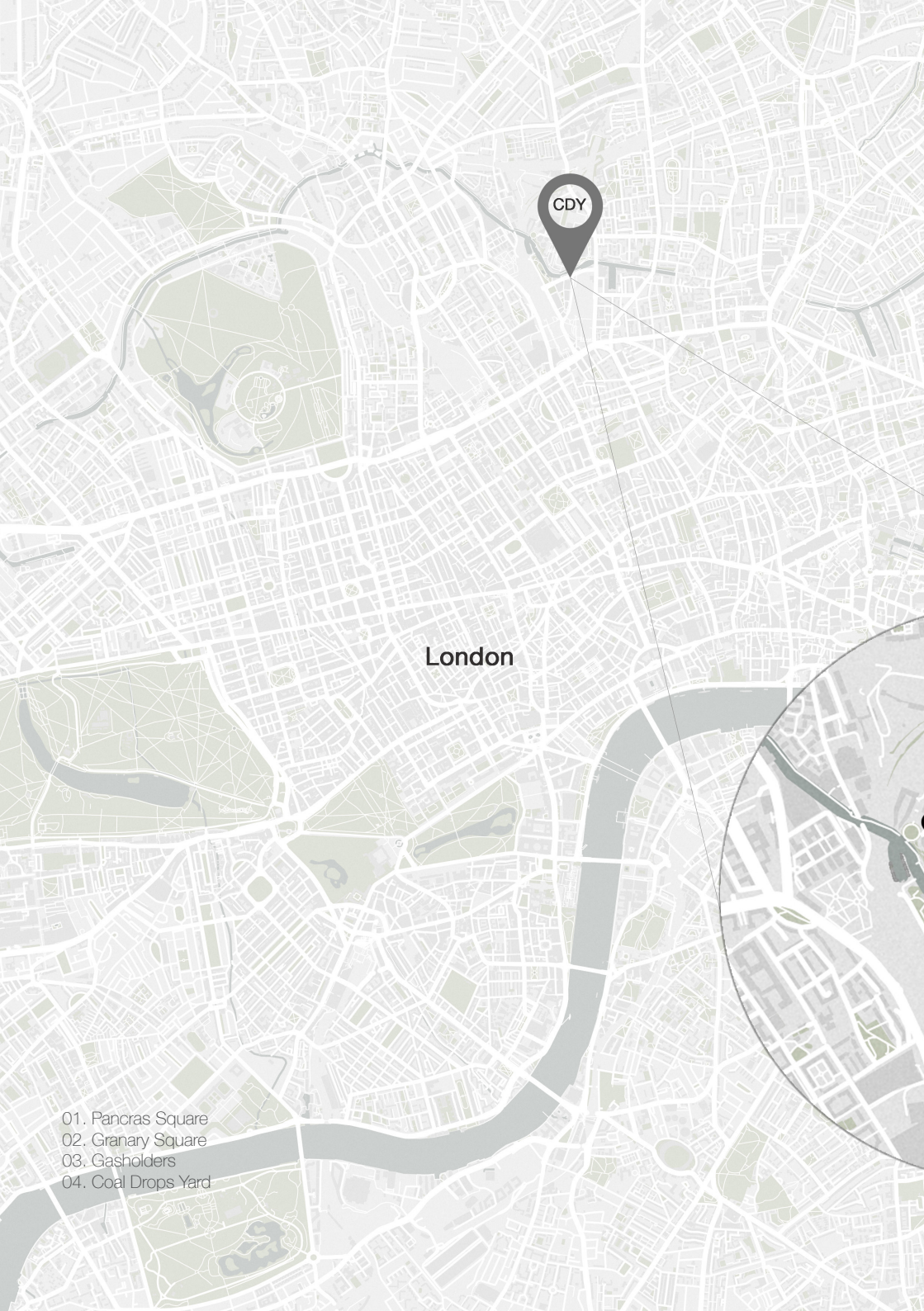

CDY

London

- 01. Pancras Square
- 02. Granary Square
- 03. Gasholders
- 04. Coal Drops Yard

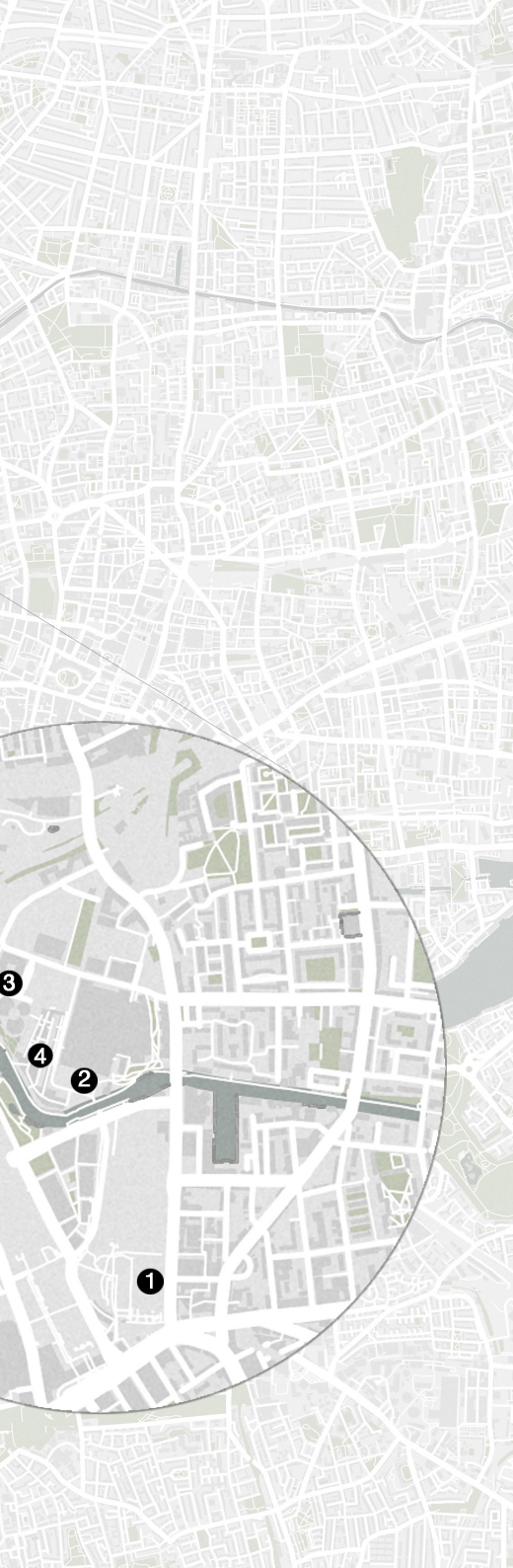

The Site: Coal Drops Yard



The context for this work is provided by two railway arches situated between the Regents Canal and Coal Drops Yard at Kings Cross in London.

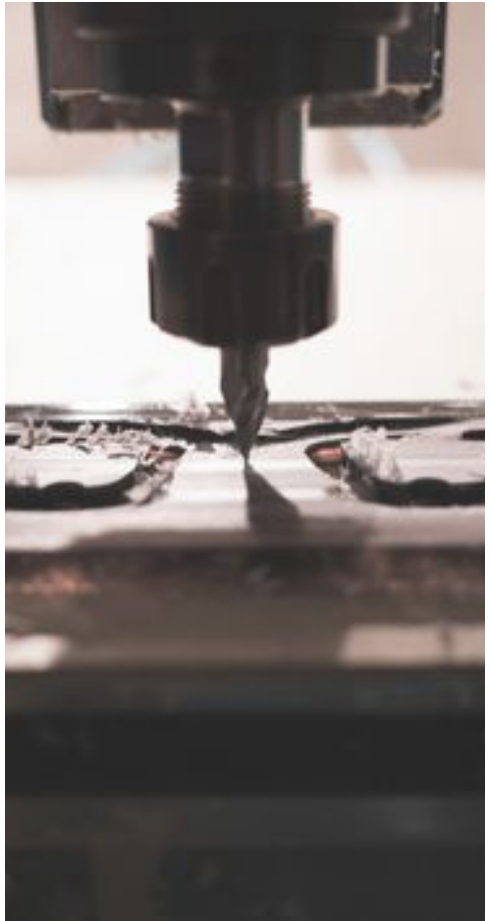

CNC Procedure

The Concept



Handcrafted Details



Structural Rivet / Logo

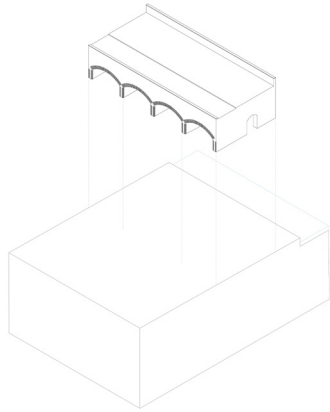

Existing Site

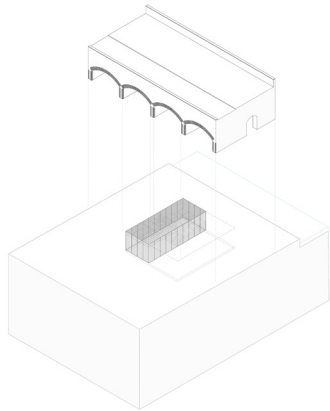

Volume A - Metal Panels

Design Strategy

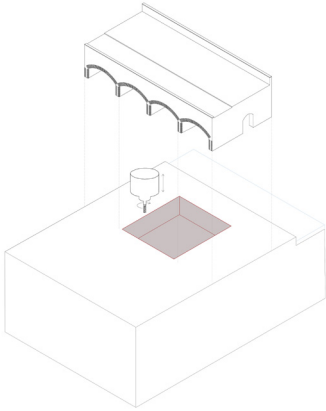

CNC procedure

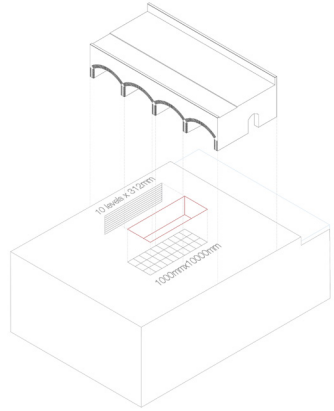

Grid: "The ten layers of the eye"

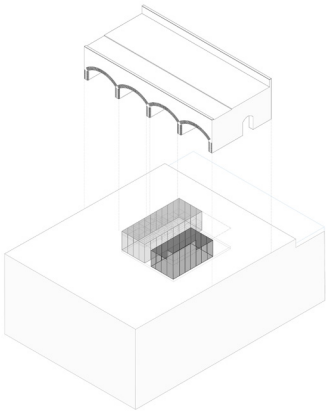

Volume B - Wooden Panels

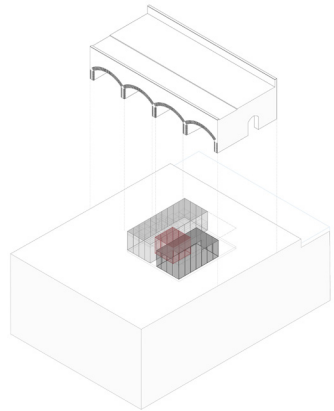

Volume C - Mirror Panels

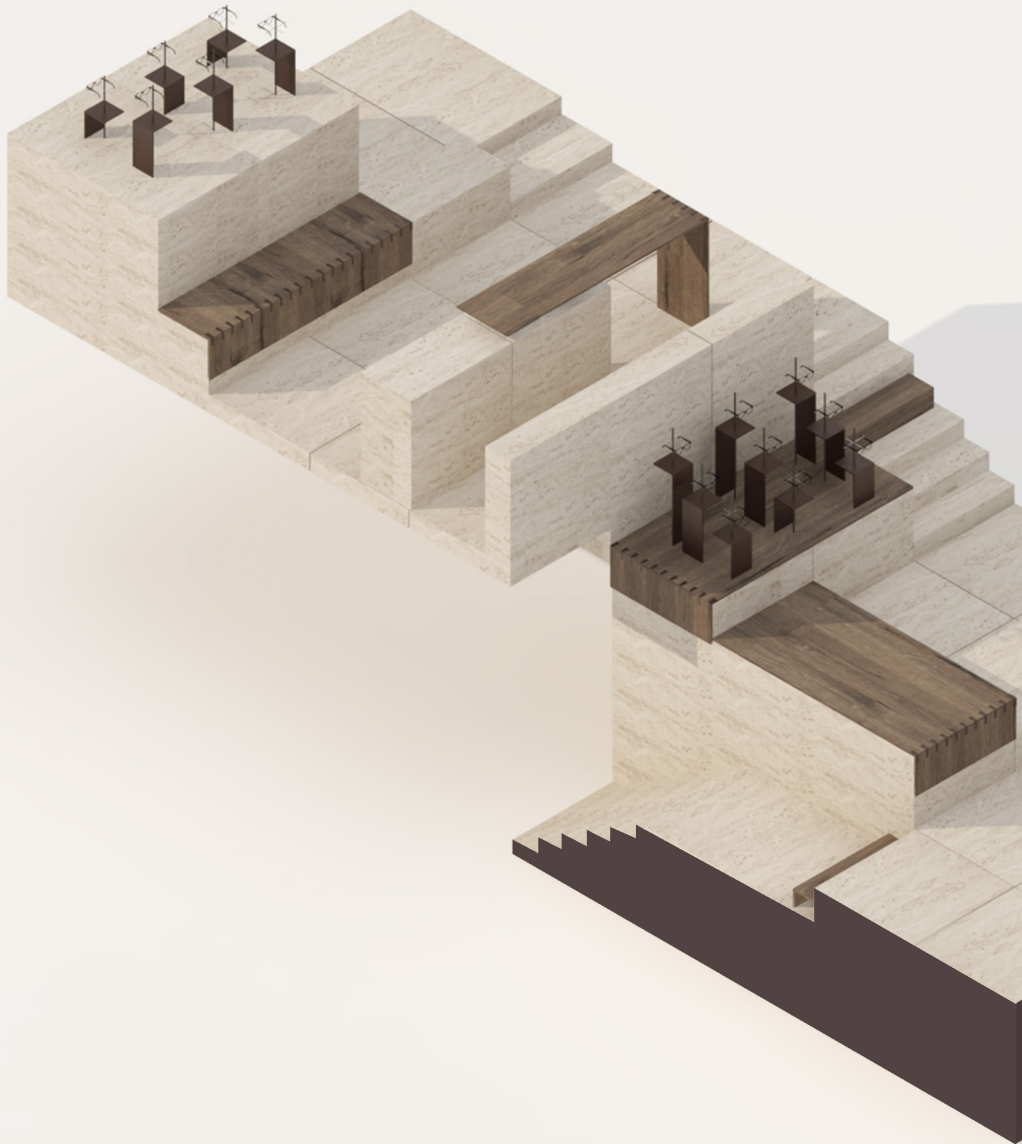



Design Scheme

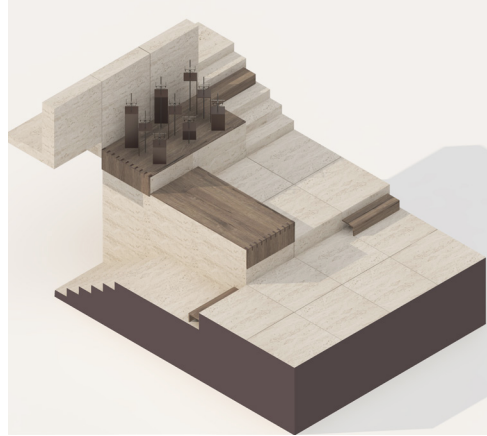

360° Rotation



Rotating Display Structure





Materials Palette

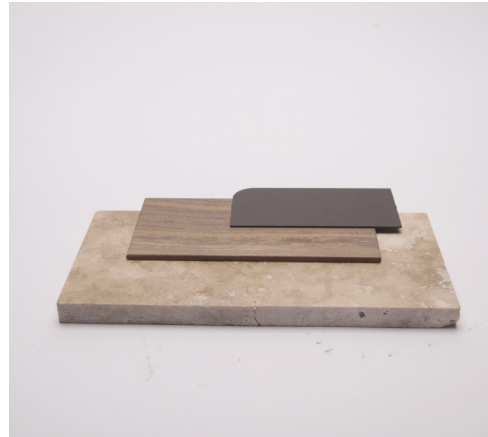

Primary Materials Palette



Secondary Materials Palette





Visuals





Visuals



Curiosity is gluttony. To see is to devour.

Here's a beautiful fact. Your eyes have ten layers. You see through so much.

When they come to write your biography, it's the subtlest of details which reveal the grand schema.

Obsessions are only obsessions to noobs. To obsessives, their obsessions are the very stuff of life.

The real voyage of
seeking new lands
eyes.

Frames which fit
reality



Visuals



“Obsessions are only obsessions to non-obsessives.
To obsessives their obsessions are the very stuff of life.”